

<b>UNLESS OTHERWISE SPECIFIED</b>				DO NOT SCALE DRAWING	
THIRD ANGLE PROJECTION DIMENSION ARE IN MILLIMETERS ±0.4 ON WHOLE NUMBERS ±0.2 ON ONE DECIMAL PLACE ±0.1 ON TWO DECIMAL PLACES				ISSUE:- <b>ISSUE 1</b>	
				FINISH:	
				TITLE: Becherspender mit Federautomatik (Röhre Kunststoff) und Silikondichtungen für verschiedene Bechergößen mit Durchmesser von ca. 69 - 98 mm	
DRAWN	C.JP	SIGNATURE	DATE	DWG NO.	TBA
CHK'D			20/10/10		A3
APP'VD					
MFG					
Q.A				MATERIAL:	
				WEIGHT:	
				SCALENTS	SHEET 1 OF 1

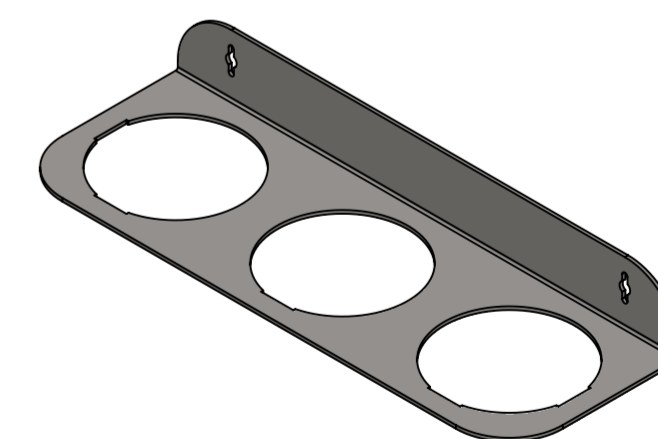
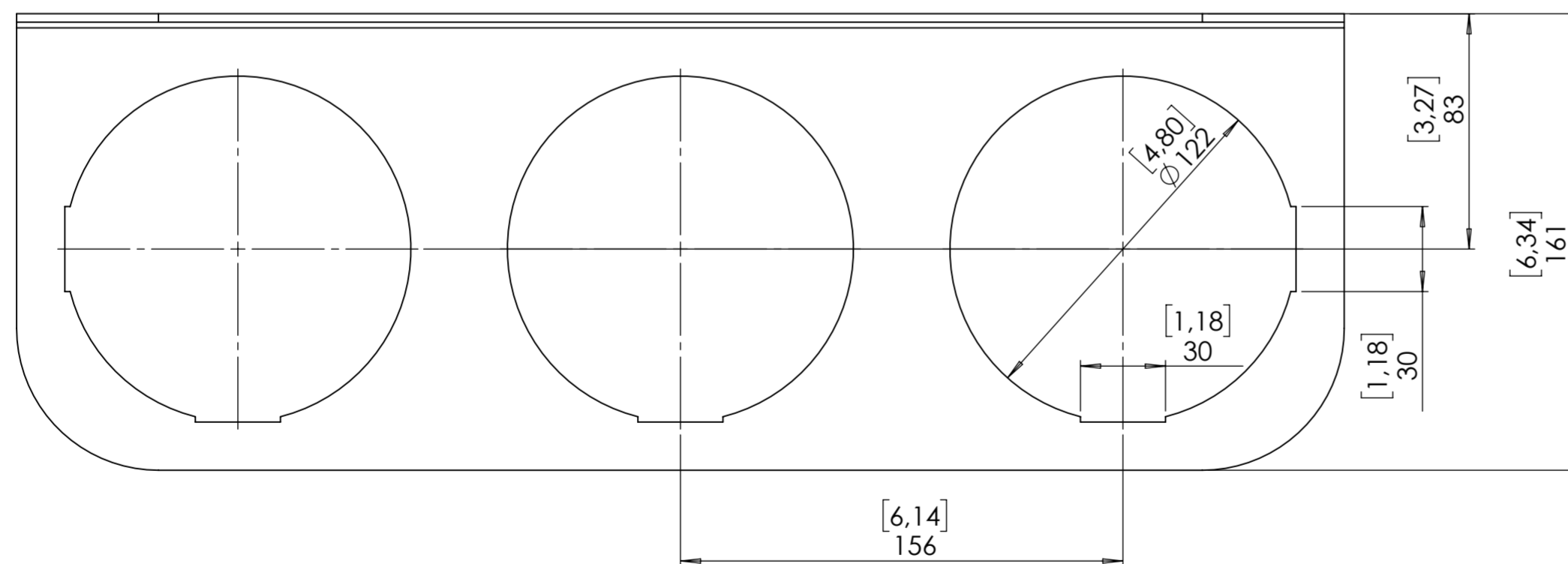
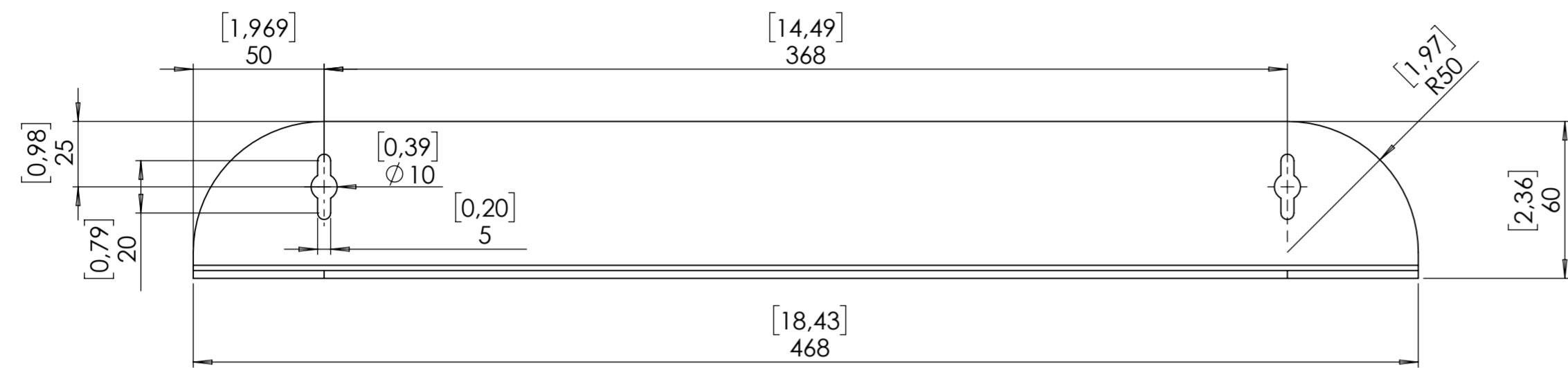

Maße: [inch]  
mm

**Materialstärke:**

Bemassung hat Vorrang vor CAD

Nicht bemaste Einzelheiten siehe Daten

GEZEICH.	DATUM	NAME
GEPRÜFT		
GENEHM.		
MATERIAL:		
FARBE:		
GEWICHT:		

INDEX	DATUM	BEMERKUNG	NAME
BENENNUNG: Anbauhalterungsbügel Angle holder for wall attachment			
ZEICHNUNGSNR.			
Format DIN A2			

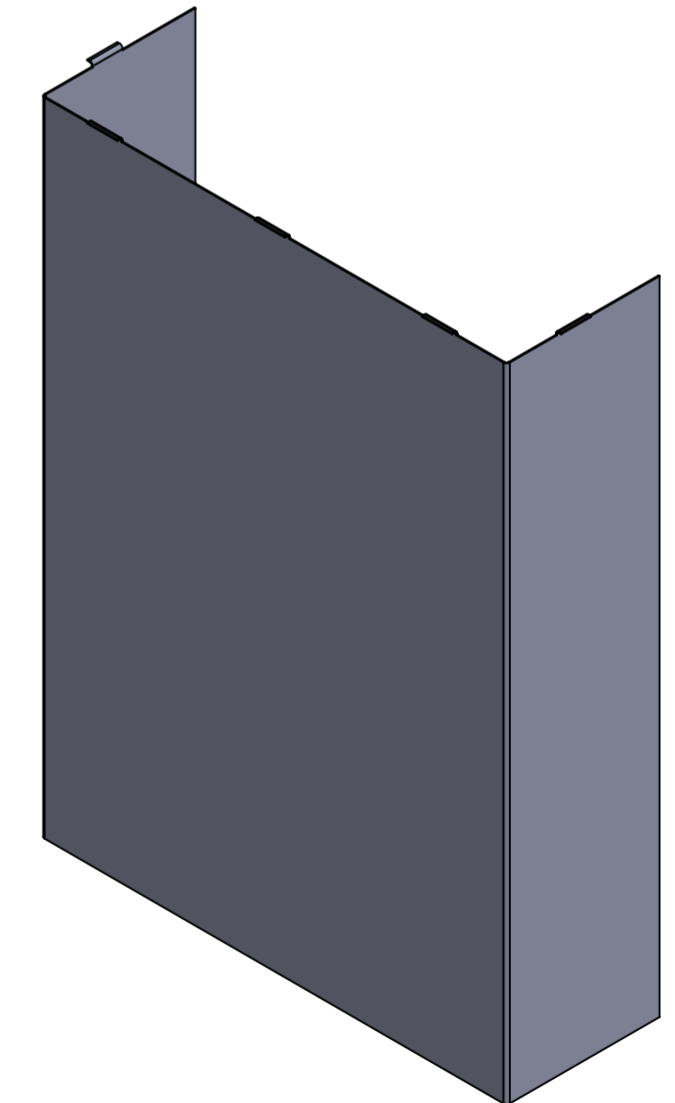
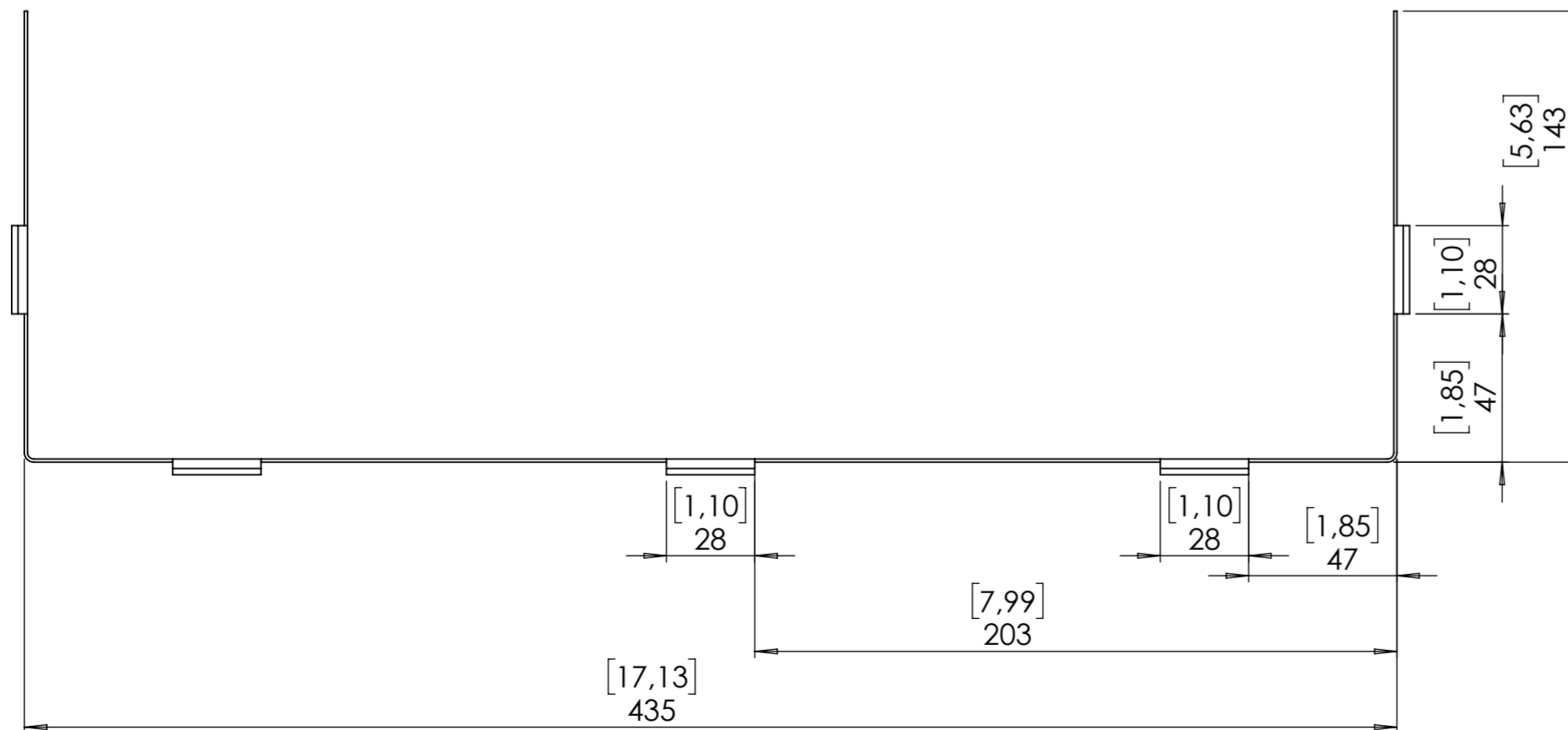
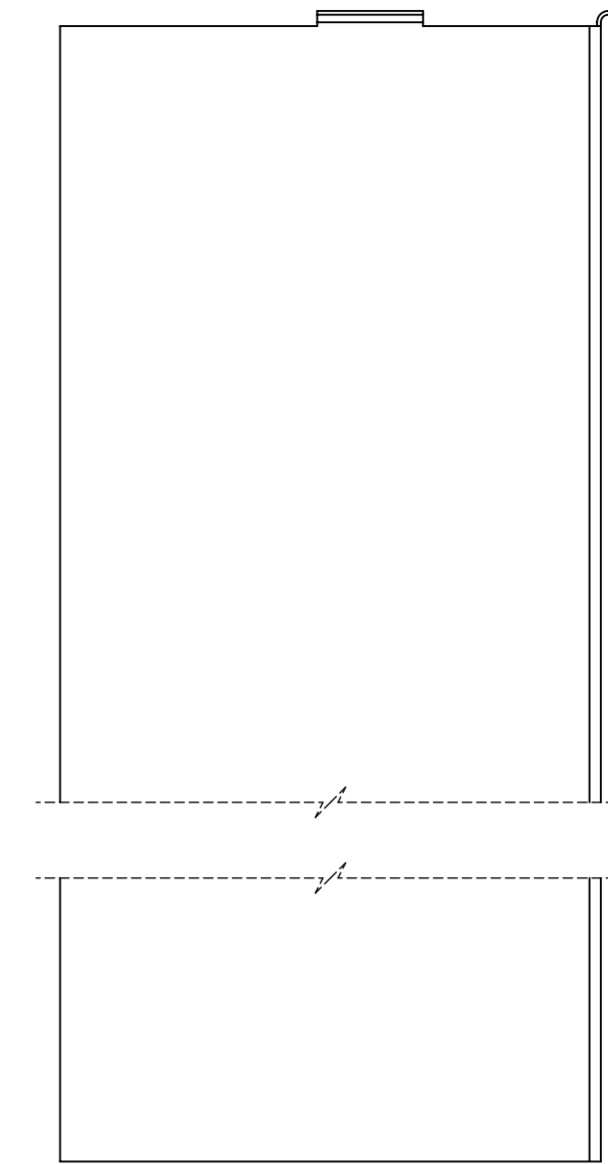
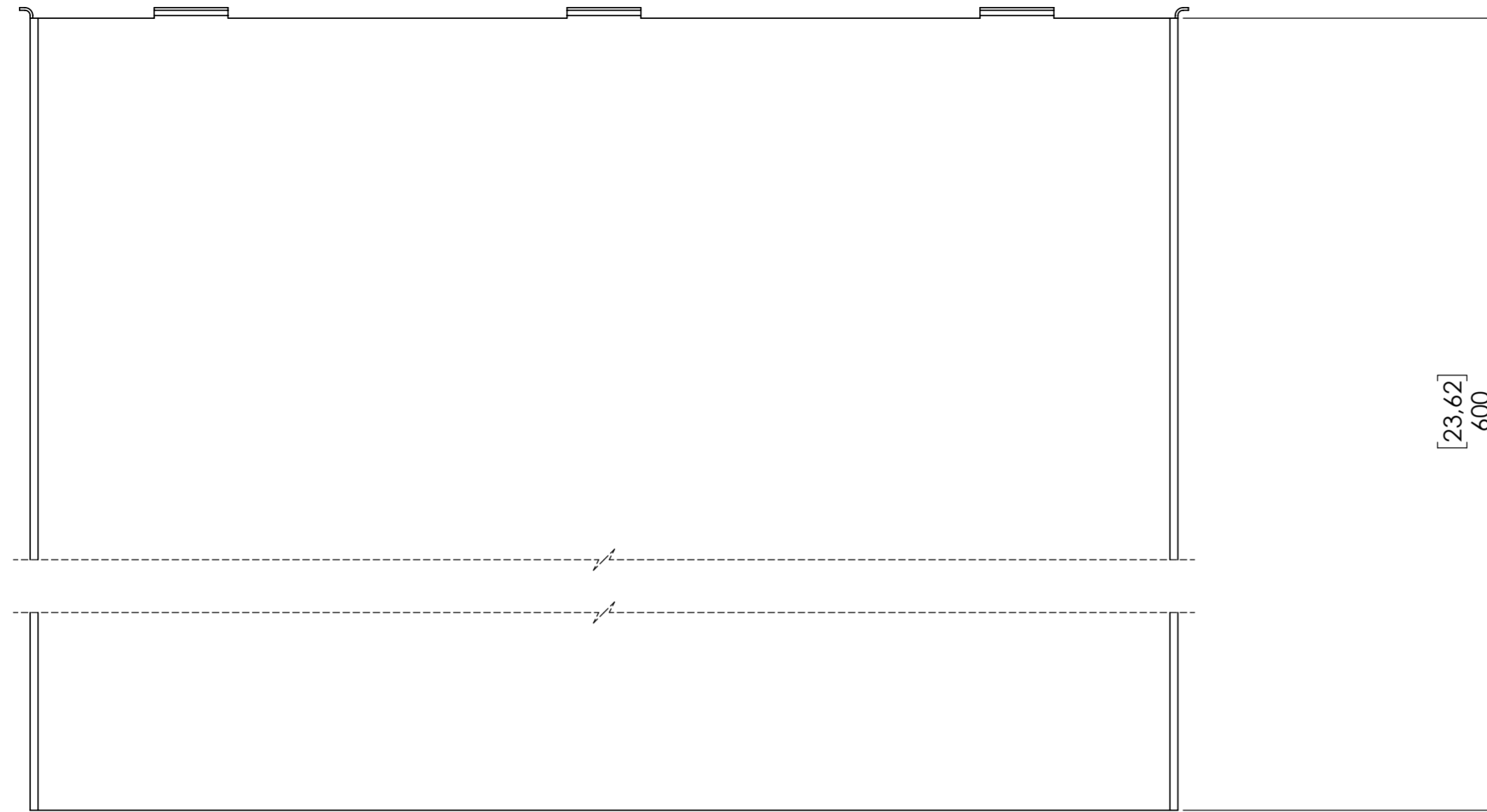

Maße: [inch]  
mm

**Materialstärke:**

Bemassung hat Vorrang vor CAD

Nicht bemaste Einzelheiten siehe Daten

	DATUM	NAME
GEZEICH.		
GEPRÜFT		
GENEHM.		
MATERIAL:		
FARBE:		
GEWICHT:		

INDEX	DATUM	BEREMKUNG	NAME
BENENNUNG: <b>Blende</b> <b>Cover plate</b>			
			Format DIN A2