

9.3 - 230V/50Hz wiring diagram - Ice crusher

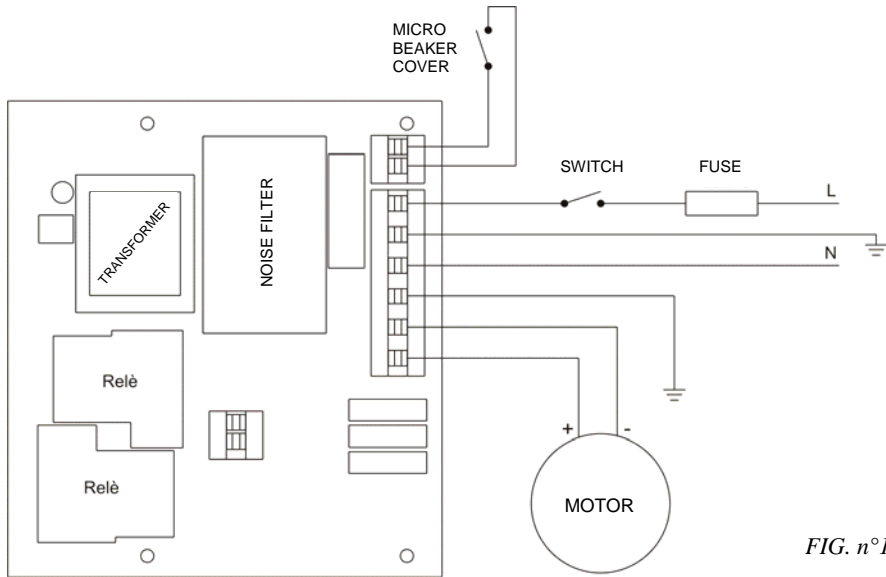

FIG. n°16

9.4 - 230V/50Hz wiring diagram - Drink mixer

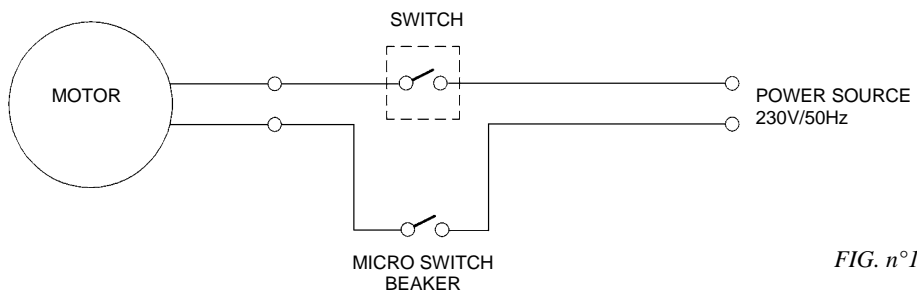
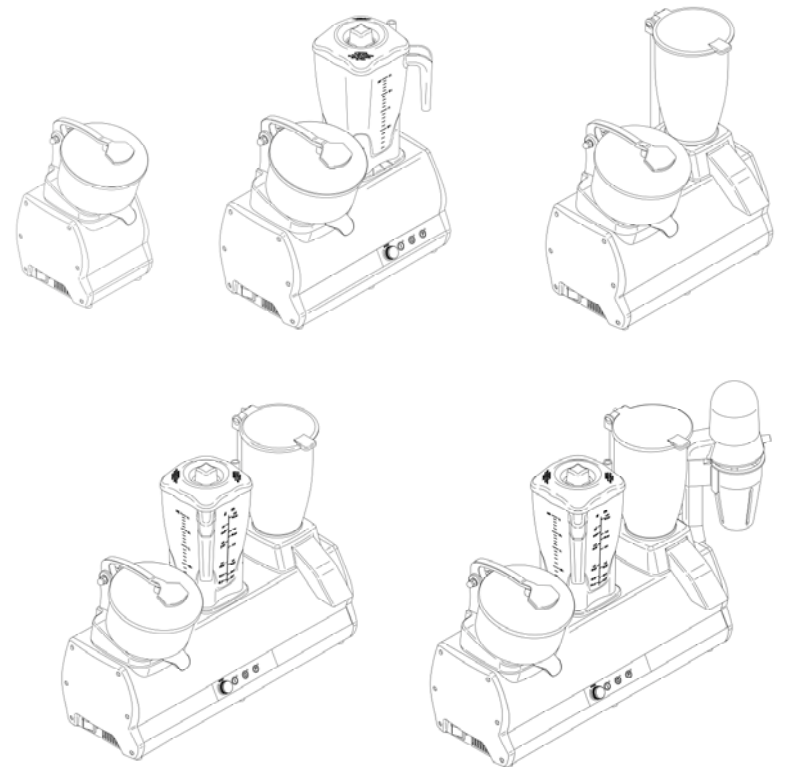

FIG. n°17

**SERVICE CENTRE
AUTHORISED DEALER**

OPERATING AND MAINTENANCE MANUAL



Ed. 11/2015

MODULAR BAR GROUPS

INTRODUCTION

- This instruction manual gives the customer all the necessary information about the appliance and the manufacturing standards applied, as well as all instructions for use and maintenance so that the appliance can be used correctly maintaining its efficiency in time.
- This instruction manual is for the end user and for service personnel.

INDEX

CHAP. 1 - INFORMATION ABOUT THE APPLIANCE	pag. 4
1.1 - GENERAL WARNINGS	
1.2 - SAFETY FEATURES INSTALLED	
1.2.1 - and mechanical safety protections	
1.3 - DESCRIPTION OF THE MACHINE	
1.3.1 - general description	
1.3.2 - constructive characteristics	
1.3.3 - components	
CHAP. 2 - TECHNICAL DATA	pag. 7
2.1 - OVERALL DIMENSIONS, WEIGHT, CHARACTERISTICS ...	
CHAP. 3 - CONSIGNING THE APPLIANCE	pag. 8
3.1 - TRANSPORTING THE APPLIANCE	
3.2 - CHECKING PACKAGING UPON CONSIGNMENT	
3.3 - DISPOSING OF PACKAGING	
CAP. 4 - INSTALLING THE APPLIANCE	pag. 9
4.1 - APPLIANCE LOCATION	
4.2 - SINGLE-PHASE ELECTRIC CONNECTION	
CAP. 5 - USING THE APPLIANCE	pag. 10
5.1 - CONTROLS	
5.2 - CHECKING THE OPERATION	
5.2.1 - Juicer	
5.2.2 - Blender	
5.2.3 - Ice crusher	
5.2.4 - Drink mixer	
5.3 - LOADING PRODUCTS	
5.3.1 - Juicer	
5.3.2 - Blender	
5.3.3 - Ice crusher	
5.3.4 - ADJUSTING ICE THICKNESS	
5.3.5 - Drink mixer	

CHAP. 9 - WIRING DIAGRAMS

9.1 - 230V/50Hz wiring diagram - Juicer

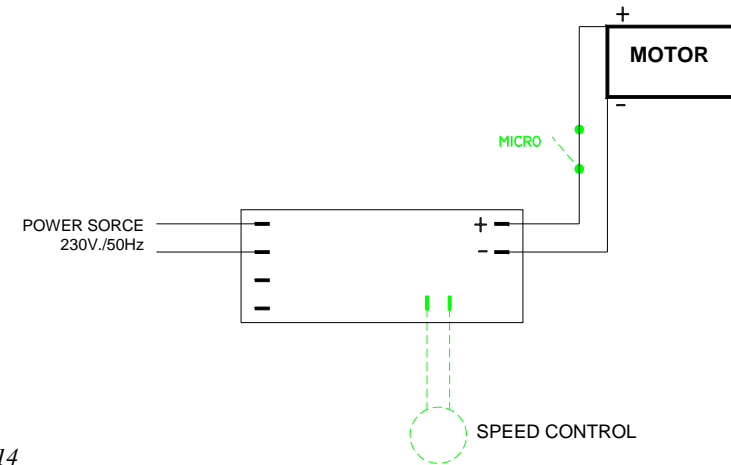

FIG. n°14

9.2 - 230V/50Hz wiring diagram - Blender

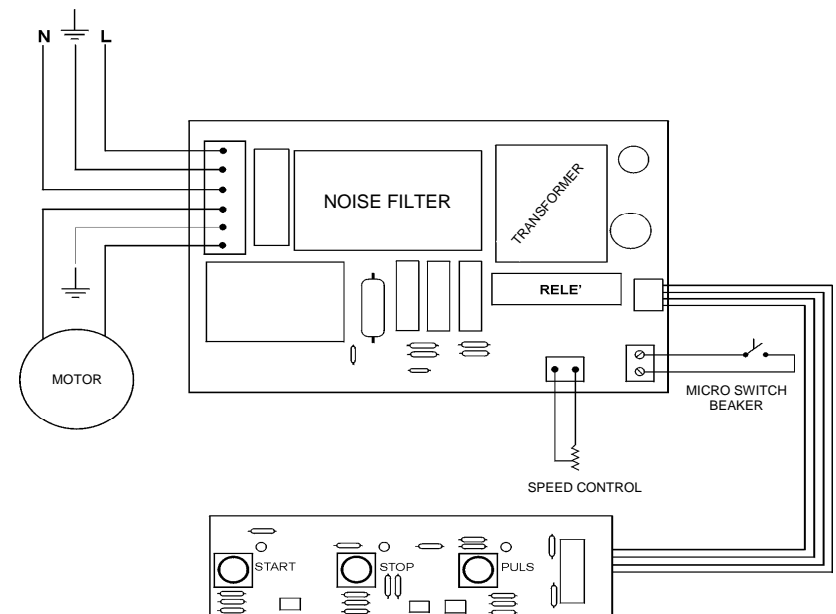

FIG. n°15

CHAP. 7 - MAINTENANCE

7.1 - GENERAL RULES

Before carrying out maintenance operations, it is necessary to:

disconnect the machine from the power supply in order to insulate the machine from the rest of the system.

7.2 - POWER CORD

Check the wear of the cord regularly and call the “SERVICE CENTRE” for the replacement, if necessary.

7.3 - BLADES

If the blades stop cutting, call the “SERVICE CENTRE”.

CHAP. 8 - DISMANTLING

8.1 - DECOMMISSIONING

If you decide to decommission the machine, make sure that nobody can use it: **disconnect and cut the electric connections.**

8.2 - WEEE Waste of Electric and Electronic Equipment



Directive 2002/95/EC, 2002/96/EC and 2003/108/EC on the restriction of the use of certain hazardous substances in electrical and electronic equipment, and waste electrical and electronic equipment .

This symbol, crossed out wheeled bin, on the product or on its packaging indicates that this product must not be disposed of with your other household waste.

Separate waste collection of this appliance is organised and managed by the manufacturer. It is the user’s responsibility to contact the manufacturer and follow the waste treatment system the manufacturer has adopted for separate waste collection.

The separate collection and recycling of your waste equipment at the time of disposal will help to conserve natural resources and ensure that it is recycled in a manner that protects human health and the environment.

CAP. 6 - ORDINARY CLEANING

- 6.1 - GENERAL RULES
- 6.2 - PROCEDURE FOR CLEANING THE MACHINE
 - 6.2.1 - Juicer
 - 6.2.2 - Blender
 - 6.2.3 - Ice crusher
 - 6.2.4 - Drink mixer

pag. 16

CAP. 7 - MAINTENANCE

- 7.1 - GENERAL RULES
- 7.2 - POWER CORD
- 7.3 - BLADES

pag. 18

CAP. 8 - DISMANTLING

- 8.1 - DECOMMISSIONING
- 8.2 - WEEE Waste of Electric and Electronic Equipment

pag. 18

CAP. 9 - WIRING DIAGRAMS

- 9.1.1 - 230V/50Hz wiring diagram - Juicer
- 9.1.2 - 230V/50Hz wiring diagram - Blender
- 9.1.3 - 230V/50Hz wiring diagram - Ice crusher
- 9.1.4 - 230V/50Hz wiring diagram - Drink mixer

pag. 19

CHAP. 1 - INFORMATION ABOUT THE APPLIANCE

1.1 - GENERAL WARNINGS

- The appliance must only be used by personnel who has carefully studied this manual and understood all the safety standards described herein.
- If there should be a turnover in personnel, it is necessary that this manual is carefully studied before using the appliance.
- Before cleaning or servicing the appliance, disconnect the electricity power supply.
- When cleaning or servicing the appliance (safety protections removed) take into consideration all possible hazards- Residual Risks.
- When servicing or cleaning the appliance always concentrate on what you are doing and avoid any possible distractions.
- Check the electricity power cable on a regular basis; a worn or damaged cable causes a dangerous electrical hazard
- If the appliance has a presumed malfunction or does not work correctly, do not use it or repair it. Contact the “Service Centre”.
- Do not use the machine with frozen food, doughs, bones or non-food products.
- Do not put your hands or other objects in the moving parts while the machine is in use.
- Do not move the machine if the switch is not set to “0” position (OFF) and the plug is inserted.
- The manufacturer cannot be held responsible for the following situations:
 - ⇒ if the appliance or safety devices are tampered with by unauthorised personnel
 - ⇒ if **non original** spare parts are used;
 - ⇒ if the instructions given in this manual are **not carefully and correctly** followed or respected;
 - ⇒ if unsuitable cleaning products are used to clean the appliance

1.2 - SAFETY FEATURES INSTALLED

1.2.1 - electrical and mechanical safety features

Regarding electrical and mechanical safety features, this appliance conforms to the EU directives **EEC 2006/42 and 2006/95**.

- **Juicer:** micro-switch on the drive pin that allows users to activate the juicer only when citrus fruits are pressed on the reamer.
- **Blender:** safety micro-switch on the glass.
- **Ice crusher:** safety micro-switch on the cover.
- **Drink mixer:** safety micro-switch on the cup; the on-switch of the machine is not allowed if it is not placed in the right position.

Although the appliance is fitted out with electrical and mechanical safety protections that conform to the standards in force (these protections are for when the appliance is working and when it is being cleaned or serviced) there are however, **RESIDUAL RISKS** that cannot be completely eliminated and are indicated by the wording

6.2.3 - Ice crusher

NB.: before starting, disconnect the machine from the power supply

Cleaning the main unit can be done by using a neutral detergent and a wet cloth, which has to be rinsed with tepid water.

Once the whole ice crusher is cleaned, dry it and close the cup lid.

6.2.4 - Drink mixer

NB.: before starting, disconnect the machine from the power supply

- general cleaning

Rinse the cup frequently and put it in the dishwasher, using neutral detergent, whenever it has been unused for more than two hours or at least once a day.

Cleaning the shaft and the agitators has to be done whenever they have been unused for more than two hours or at least once a day.

Fill the cup with hot water (60°C) and neutral detergent, and then operate the blender for 1 minute. Change the water without adding any detergent and operate the machine again for other two cycles of the same time period.

Cleaning the main unit can be done by using a neutral detergent and a wet cloth, which has to be rinsed with tepid water. Dry every part of the machine carefully at the end of the process.

Once all the parts are cleaned, dry and install them again on the drink mixer.



FIG. n°13 - Machine disassembled for the cleaning

CHAP. 6 - ORDINARY CLEANING

6.1 - GENERAL RULES

- Cleaning the machine is an operation to be conducted once a day or more frequently, if necessary.
- It should be carried out carefully in every part of the machine coming into direct or indirect contact with the ingredients.
- The machine does not have to be cleaned with high-pressure water jet machines or water jets - please use water and neutral detergents. Tools, scrubbers or other similar instruments do not have to be used because this may cause damage.

”ATTENTION!”

Before cleaning the machine, it is necessary to:

- a) set the switch to “0”.
- b) disconnect the machine from the power supply in order to insulate the machine from the rest of the system.

6.2 - PROCEDURE FOR CLEANING THE MACHINE (*see PICTURE 13*)

6.2.1 - Juicer

ATTENTION! - Before starting, disconnect the machine from the power supply

NB: Do not put any part in the dishwasher.

- cleaning the reamer and the collecting tray

Follow the procedure below in order to clean the reamer and the tray:

- a) carefully unhook the reamer from the body;
- b) remove the collecting tray;

Once the components are removed, clean them with tepid water and a neutral detergent.

- general cleaning

Cleaning the main unit can be done by using a neutral detergent and a wet cloth, which has to be rinsed with tepid water. Dry every part of the machine carefully at the end of the process.

6.2.2 - Blender

ATTENTION! - Before starting, disconnect the machine from the power supply

- cleaning the glass

Fill the glass with hot water (60°C) and neutral detergent, and then operate the blender for 1 minute. Change the water without adding any detergent and operate the machine again for other two cycles of the same time period.

ATTENTION! - **Blades are sharp, pay attention to handling them during the cleaning operations.**

- general cleaning

Lift the lid cap and clean them by using tepid water and a neutral detergent.

Cleaning the main unit can be done by using a neutral detergent and a wet cloth, which has to be rinsed with tepid water.

Once all the parts are cleaned, dry and install them again on the blender.

ATTENTION! in this manual. These risks refer to the risk of being cut or injured by sharp components.

1.3 - DESCRIPTION OF THE MACHINE

1.3.1 - general description

The device was designed and produced by our company with the following aims:

Juicer: reaming citrus fruits.

Blender: cutting, chopping, liquidizing food products (such as fruit and vegetables).

Ice crusher: crushing traditional ice cubes (max. 25x30 mm), produced by the appropriate machine (no freezer).

Drink mixer: mixing, whisking, emulsifying milk and by-products.

Furthermore, it offers:

- safety during operation, cleaning, and maintenance;
- hygiene thanks to the careful selection of materials coming into contact with food, and the removal of corners from components coming into contact with products, in order to easily disassemble and clean the machine.
- highest performance thanks to the four-blade system (blender);
- alternating operation, with the machine switched on for 10 minutes and switched off for 10 minutes;
- highest performance thanks to the three agitators (drink mixer);
- sturdiness and stability of all components;
- highest noiselessness;
- highest manoeuvrability.

1.3.2 - structure characteristics

The main part is made of anodized steel and sides are made of ABS.

Juicer: stainless steel bowl with ABS reamer. Internal steel supporting structure.

Blender: glass and cap made of transparent, indestructible Tritan.

Ice crusher:

- SAE 304 steel container.
- ABS discharge mouth, cover and crusher.
- SAE 304 steel blade and ice crushing plate.
- (Optional) tray made of thermoformed alimentary plastic.
- Rubber feet and stainless steel screws.

Drink mixer: built out of chrome-plated ABS and anodized steel.

1.3.3 - components

Table 1 - Overview

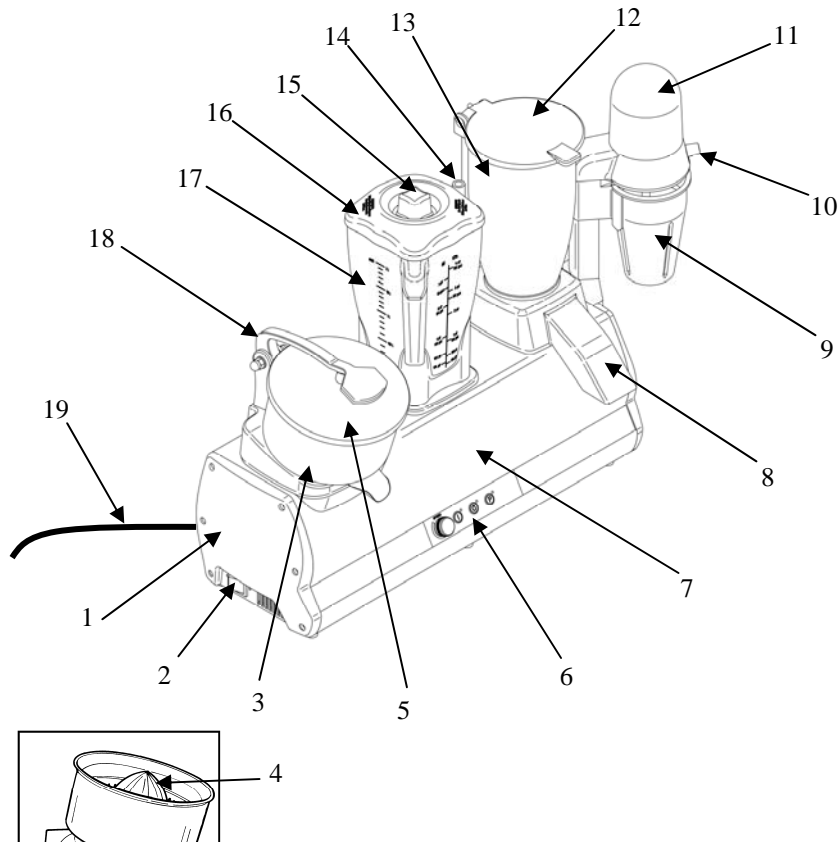

FIG. n°1

LEGEND:

- | | |
|---------------------------------------|--|
| 1. Side | 12. Cup cover of the ice crusher |
| 2. Switch of the juicer | 13. Cup of the ice crusher |
| 3. Collecting tray | 14. Micro-switch supporting staff of the blender |
| 4. Reamer of the juicer | 15. Cap for adding ingredients |
| 5. Cover of the juicer | 16. Cover of the blender |
| 6. Controls of the blender | 17. Glass of the blender |
| 7. Main unit | 18. Cover lever of the juicer |
| 8. Discharge mouth of the ice crusher | 19. Power cord |
| 9. Cup of the drink mixer | |
| 10. Speed control of the drink mixer | |
| 11. Engine head of the drink mixer | |

5.3.4 - ADJUSTING ICE THICKNESS

The procedure for adjusting ice thickness is as follows:

- 1) set the switch to "0".
- 2) move the crusher (a) forward or backward in order to adjust ice thickness.
- 3) once the desired thickness is set, ice crusher can be started.

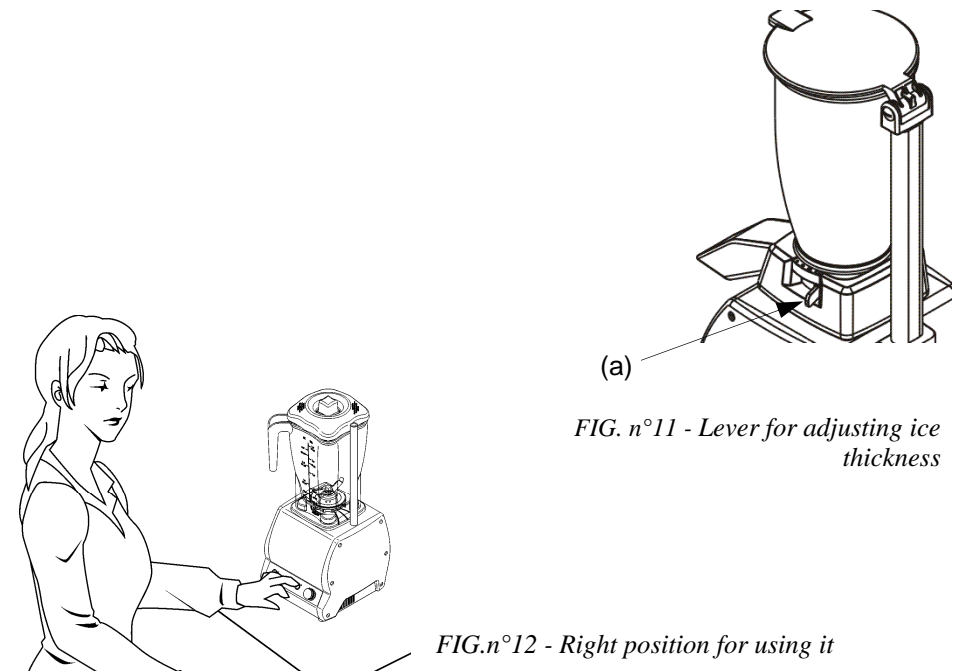

FIG. n°11 - Lever for adjusting ice thickness

FIG. n°12 - Right position for using it

5.3.5 - Drink mixer

ATTENTION! - Products have to be loaded in the cup when the switch is in the "0" position only.

1. Once the ingredients are loaded, place the cup so that it is carefully installed.
2. Make sure that the cup is secure and properly inserted.
3. Set the switch to the "I" starting position (see PICTURE 8).
4. In case of VV drink mixers, adjust the speed of the agitators by using the appropriate variator (gradually change speed from minimum to maximum).
5. do not use the drink mixer when unloaded.
6. Set the variator speed to the minimum at the end of the process, then stop the machine by setting the switch to the "0" stopping position, and remove the cup carefully.
7. Use the drink mixer in alternation, with the machine switched on for 10 minutes and switched off for 10 minutes.

7. stop the machine at the end of the process by pressing the “0” stopping button;
8. remove the glass carefully.
9. Use the blender in alternation, with the machine switched on for 10 minutes and switched off for 10 minutes.
10. **Do not move the machine if the switch is not in “0” position (OFF) and the plug is inserted.**

5.3.3 - Ice crusher

ATTENTION! - The ice to be crushed only has to be loaded in the feeding mouth when the engine is switched off. ONLY hollow ice cubes (25x30 mm, -3° C), produced by the appropriate machine (no freezer), can be used.

N.B.: the quantity of ice to be added does not have to go beyond the cup edge, otherwise the machine does not start, the lid should close easily.

The procedure is as follows:

1. choose a position so that any accidents can be avoided (*see PICTURE 12*): your body has to be perpendicular to the worktop; hands do not have to force the machine components or prevent its movements.

Do not lean on the machine or choose such a position as to touch the moving parts;

2. Adjust ice thickness according to the desired outcome (*see section 5.3.4*)
3. lift the cup lid;
4. add some ice, paying attention to quantity - the lid should be able to close;
5. start the machine by using the switch and pressing the “T” button (*see PICTURE 7*);
6. stop the machine at the end of the process by pressing the “0” stopping button;
7. do not use the ice crusher when unloaded;
8. put a container under the discharge mouth immediately at the end of the process, since the ice remaining inside the mouth gradually melts and drips, and this may be hazardous.
9. **Do not move the machine if the switch is not in “0” position (OFF) and the plug is inserted.**
10. Do not leave the ice inside the cup for a long time, it may prevent the rotation of the blades, and this may cause damage.

CHAP. 2 - TECHNICAL DATA

2.1 - OVERALL DIMENSIONS, WEIGHT, CHARACTERISTICS ...

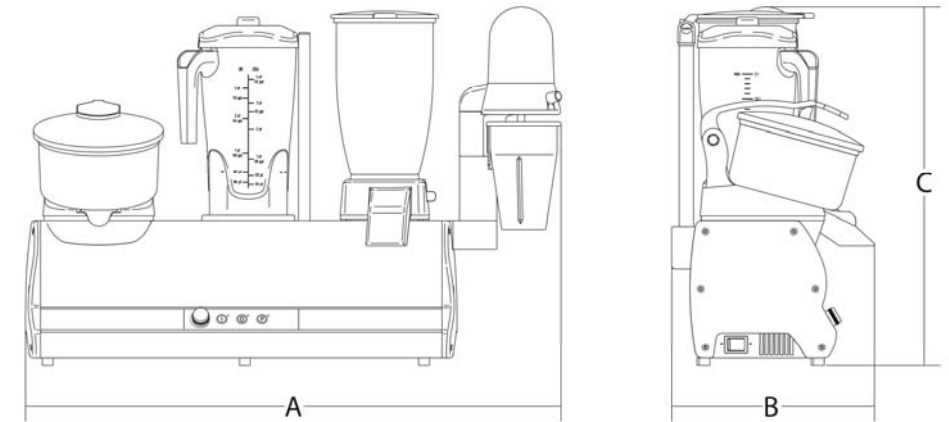

FIG. n°2

TAB. n°1 - MEASUREMENTS AND TECHNICAL CHARACTERISTICS

	Power	Power source	Revolutions/min.	A	B	C	Net weight
	watt		r.p.m.	mm	mm	mm	Kg
GR1 SA	150	230V 50/60 Hz	320	202	242	370	4,2
GR2 SAFR	150-750	230V 50/60 Hz	320 / 8.000÷16.000	402	242	486	9,2
GR2 SARG	150-150	230V 50/60 Hz	320 / 800	402	283	495	9,5
GR2 FRRG	750-150	230V 50/60 Hz	8.000÷16.000 / 800	402	283	495	10,2
RG3 SAFRRG	150-750-150	230V 50/60 Hz F+N	320 / 8.000÷16.000 / 800	602	283	495	13,7
GR4 SAFRRGFP	150-750-150-100	230V 50/60 Hz F+N	320 / 8.000÷16.000 / 800 / 14.000	747	283	501	16,5

SA = Juicer
FR = Blender
RG = Ice crusher
FP = Drink mixer

ATTENTION! the appliance is designed for the electrical specifications given on the plate applied to the rear of the appliance; before connecting to the electricity power supply refer to chapter 4.2 connecting to the electricity supply.

CHAP. 3 - CONSIGNING THE APPLIANCE

3.1 - TRANSPORTING THE APPLIANCE (see FIG. n°3)

The fruit-squeezer leaves our warehouse carefully packed; packaging consists in:

- a resistant cardboard box;
- the appliance;
- this manual;
- CE Certificate of Conformity.

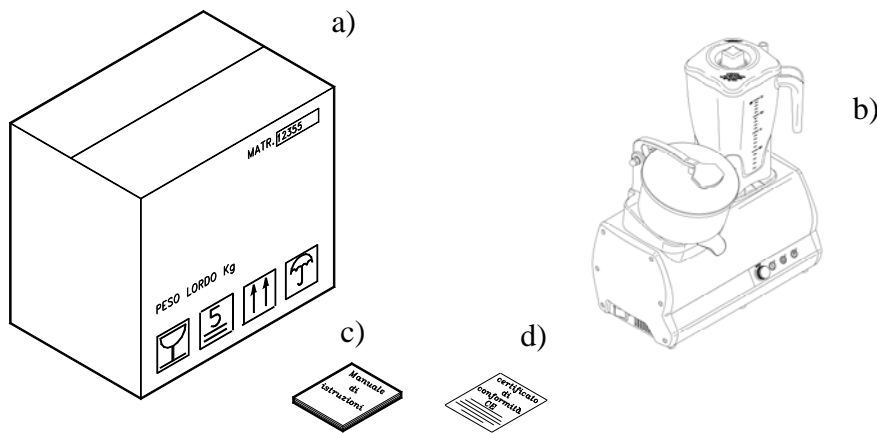

FIG. n°3 - Packaging

3.2 - CHECKING PACKAGING UPON CONSIGNMENT

When the goods are received proceed with opening the packaging if there are no signs of damage, and make sure that inside there are all the listed items (see Fig. n°3). If when the goods are delivered there are signs of damage to the packaging, such as dents or if they have been dropped, immediately inform the forwarding agent or courier, and within three days from the date indicated on the documents draw up a detailed list and report of all damage to the goods. **Do not turn the packed goods upside down!!** When transporting the package make sure its four main points are firmly secured (maintain the goods parallel to the ground).

3.3 - DISPOSING OF PACKAGING

The various items used for packaging (cardboard, plastic straps) are normal urban waste products and can be disposed of without difficulty. If the appliance is destined to countries where there are specific standards regarding waste, dispose of packaging respecting the standards and laws in force.

5.3 - LOADING PRODUCTS

5.3.1 - Juicer

The procedure is as follows:

- choose a position so that any accidents can be avoided (see PICTURE 12): your body has to be perpendicular to the worktop; hands do not have to force the machine components or prevent its movements.

Do not lean on the machine or choose such a position as to touch the moving parts;

- set the switch to the “I” position (see PICTURE 5);
- Without lever:** put the already-chopped citrus fruit on the reamer and slightly press on it so that the machine starts. If necessary, increase speed by rotating the speed variator knob clockwise (**only in VV modes**).

N.B.: the machine stops when the reamer is not pressed.

- With lever:** put the already-chopped citrus fruit on the reamer and slightly lower the lever until the fruit is completely squeezed. If necessary, increase speed by rotating the speed variator knob clockwise (**only in VV modes**).

- Use the juicer in alternation, with the machine switched on for 10 minutes and switched off for 10 minutes.

N.B.: the machine stops when the reamer is not pressed.

- finally, set the switch to the “0” stopping position.
- Do not move the machine if the switch is not in “0” position (OFF) and the plug is inserted.**

5.3.2 - Blender

The products to be liquidized have to be chopped and loaded in the glass when the engine is switched off, paying ATTENTION to the blades.

N.B.: Do not use products with bones, seeds or similar ingredients; any addition only has to be done through the cap when the machine is in use.

The procedure is as follows:

- choose a position so that any accidents can be avoided (see PICTURE 12): your body has to be perpendicular to the worktop; hands do not have to force the machine components or prevent its movements.

Do not lean on the machine or choose such a position as to touch the moving parts;

- remove the lid from the glass;
- ATTENTION!** - put the product inside the glass paying attention to the blades; if large products are used, chop them manually before adding them in the glass;
- make sure that the lid is placed correctly, paying **ATTENTION** to the position of the micro-switch bearing, which needs to be in line with the radius of action of the magnet, in order to make the blender work, as PICTURE 9 shows.
- Start the machine by pressing the “I” button (see PICTURE 6) and, if necessary, increase speed by rotating the speed variator knob; in case of too many vibrations of the glass, hold it firmly.
- add any ingredients by using the lid hole during the process;

5.2.3 - Ice crusher

Before carrying out the test, make sure that:

- a) the lid is sufficiently lowered to react with the magnetic micro-switch (*PICTURE 10 - ref. a*); then, check the operation of the machine as follows:
 1. set the switch to the "I" position (*see PICTURE 7*);
 2. check if the machine stops when the lid is lifted.
 3. finally, set the switch to the "0" stopping position.

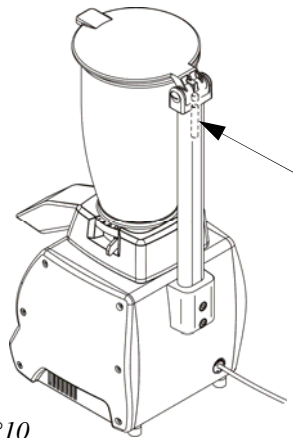

- (a) Micro-switch:
it stops the ice crusher with the glass lid is lifted.

FIG. n°10

5.2.4 - Drink mixer

Before carrying out the test, make sure that the cup is locked, and then check the operation of the machine as follows:

1. set the switch to the "I" starting position and to the "0" stopping position (*see PICTURE 8*);
2. check the rotation of the agitators, always with the cup installed, by alternating the position of the switch in "I" and "0";
3. check if the machine switches off when the cup is removed.
4. finally, set the switch to the "0" stopping position.

CHAP. 4 - INSTALLING THE APPLIANCE

4.1 - APPLIANCE LOCATION

The work surface where the appliance will be located must be suitable for its size, please refer to the measurements given in Tab. 1. (depending on the model). The work surface must be level dry, smooth, socover and stable.

The appliance must be located in a non-salty environment with a max humidity value of 75% and with a temperature between +5° and +35°C; and however, always in areas and environments that do not cause any type of malfunction to the appliance.

4.2 - SINGLE-PHASE ELECTRIC CONNECTION

The machine is equipped with a power cord with a 3x0.75 mm² section; 1.5 m long and with a "SCHUKO" plug.

Connect the machine 230 Volt 50 Hz, by using a 10 A residual-current circuit breaker, $\Delta I = 0.03A$. Then, make sure that the earthing system is in working order.

Check that the technical data-matriculation number plate (*PICTURE 4*) matches with the data contained in the documents delivered with the machine.

Mod.	_____	_____	_____	Watt.		
Matr.	_____	_____	_____	Hz.		
	_____	H.p.	_____	A.	_____	Hz.
○	_____	~	Volts.	_____	Kg.	○
Anno	_____	_____	_____	_____	_____	_____

FIG. n°4 - Technical data - registration number

CHAP. 5 - USING THE APPLIANCE

5.1 - CONTROLS

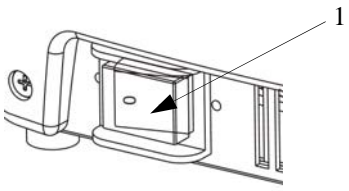
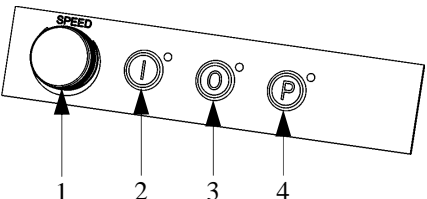
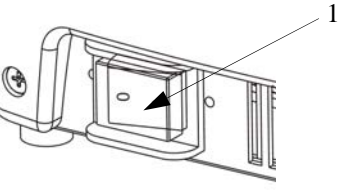
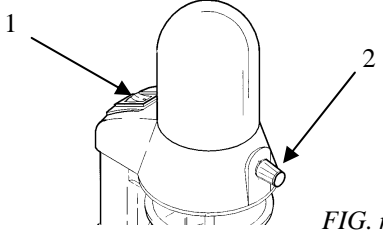
<p>JUICER:</p>  <p>FIG. n°5</p>	<p>1. <i>O/I</i> switch</p>
<p>BLENDER:</p>  <p>FIG. n°6</p>	<p>1 "SPEED" Speed control knob 2 "I" start 3 "O" stop 4 "P" pulse</p>
<p>ICE CRUSHER</p>  <p>FIG. n°7</p>	<p>1. <i>O/I</i> switch</p>
<p>DRINK MIXER:</p>  <p>FIG. n°8</p>	<p>1. <i>O/I</i> switch 2. Speed control for the agitators, in the VV version.</p>

5.2 - CHECKING THE OPERATION

5.2.1 - Juicer

Follow the procedure below in order to check the operation of the machine:

1. set the switch to the "I" position (see PICTURE 5);
2. check that the machine starts by pressing the reamer only;
3. finally, set the switch to the "0" stopping position.

5.2.2 - Blender

Before carrying out the test, make sure that the cover is in the right position (when the micro-switch bearing is in line with the magnet (see PICTURE 9)), then check the operation of the machine as follows:

1. set the switch to the "I" position (see PICTURE 6);
2. check the rotation of the blades, always with the glass installed - change the speed by rotating the variator knob, if any;
3. check if the machine stops when the cover is removed.
4. finally, set the switch to the "0" stopping position.

Blender with square glass

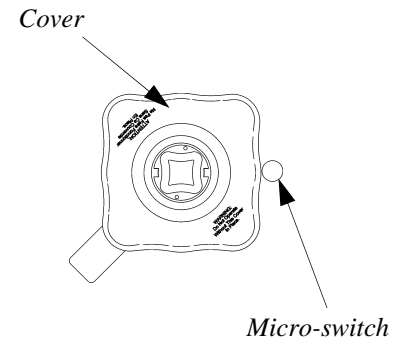

Blender with round glass

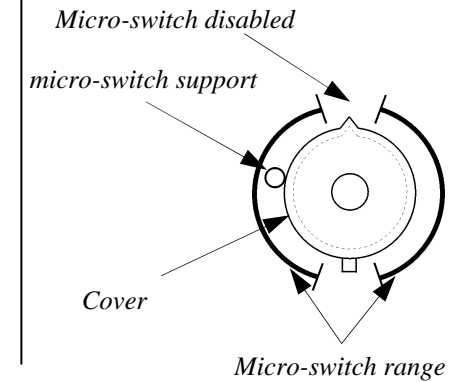

FIG.n°9 - Right position of the cover



GGM Gastro International GmbH
Weinerpark 16
D-48607 Ochtrup

www.ggmgaastro.com info@ggmgaastro.com
+49 2553 7220 0