



# USER MANUAL & MAINTENANCE

## Suction Hood

## INTRODUCTION

*Dear client, thank you and congratulations on buying this appliance; we are confident that this is the beginning of a positive and long-lasting collaboration. This manual has all the information necessary to correctly use, maintain and install this appliance. The objective of this manual is to enable the technician and user to take all measures and precautions necessary for the safe, efficient, long-term use of the appliance. Keep this booklet in a safe place, for the entire life of the product for subsequent reference by authorised operators and specialist technicians. If documents are lost or damaged, replacements must be requested directly from the manufacturer or retailer. The manufacturer is not held liable for any damage caused by people or things or for inappropriate use of the appliance, modifications or repairs carried out by unauthorised personnel or used with spare parts not recommended by the manufacturer and not intended for use with this model. This appliance complies with the EEC directives in force.*

# SUMMARY

SAFETY WARNINGS .....	4
INSTALLER INSTRUCTIONS.....	4
2.1 DATA LABEL .....	4
2.2 PRELIMINARY OPERATIONS .....	6
2.3 PLACE OF INSTALLATION .....	6
2.4 REMOVING PROTECTIVE FILM ETC. ....	7
2.5 POSITIONING .....	8
ELECTRICAL CONNECTION.....	10
3.1 REPLACING THE POWER SUPPLY CABLE .....	10
3.2 EQUIPOTENTIAL CONNECTION .....	11
WATER CONNECTION .....	12
FUME DISCHARGE CONNECTION.....	13
5.1 WATER DISCHARGE.....	15
INSTALLATION OF FILTERS.....	16
6.1 FRONTAL FILTERS .....	16
6.2 CARBON FILTERS.....	16
INSTALLATION PLATE .....	17
INSTRUCTIONS FOR THE USER .....	20
8.1 WARNINGS.....	20
8.2 CONTROLS FOR WATER HOODS.....	20
8.2 CONTROLS FOR AIR HOODS.....	20
ORDINARY MAINTENANCE.....	21
9.1 CLEANING THE OUTER SHELL .....	21
9.2 CLEANING THE FILTERS .....	21
MAINTENANCE IN CASE OF BREAKAGE .....	22
10.1 SPARE PARTS .....	23



# SAFETY WARNINGS

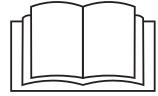

Read this instructions booklet carefully before starting the installation and start-up operations. All installation, assembly, assistance and extraordinary maintenance operations must be carried out by qualified personnel and supplied with necessary professional requirements (authorisations by the manufacturer or retailer), in accordance with local laws regarding product and workplace safety in force in the place of installation. Incorrect installation, assistance, maintenance, cleaning, tampering with, or modifications can cause malfunctions, damage, and injuries. The appliance must be used exclusively for the purpose for which it was intended, in other words for the suction of hot steam exiting the oven on which it is positioned. Any other use is inappropriate and dangerous.

## INSTALLER INSTRUCTIONS

### 2.1 DATA LABEL

XXXXXX  
 Art.: XXXXX  
 Model.: XXXXX  
 Ref.: XXXXXXXXXXXXX  
 Ser. N.:   
 AC-0J0600005

TYPE:

INFORMATION	IPX3	kPa:	
POWER	0.3 kW	220-240V ~	50/60 Hz
WEIGHT	KG: 30	Ord: 21/2606	

RoHS  
MADE IN ITALY



POWER SUPPLY

POWER SUPPLY  
FREQUENCY



## 2.2 PRELIMINARY OPERATIONS

On receipt of the suction hood, make sure it has not been damaged during transport and that the packaging has not been tampered with. In the case of damage or missing parts, inform the carrier and retailer/manufacturer immediately, indicating the code (Art.) and serial number (Ser N°) and attach a photo. Check that the installation area is kept clear so that doors, corridors and passageways are accessible.



### ATTENTION!



The appliance may fall over during transport, leading to breakage and damage to property and people. Use suitable transport that can withstand the weight of the appliance. Do not drag or tilt the appliance for any reason. Lift it up straight from the ground and move it horizontally.

---

## 2.3 PLACE OF INSTALLATION

The appliance must be installed in an enclosed and well ventilated area (not outdoors). The ambient temperature of the place of installation of the appliance must not fall below +4° C. Before positioning the suction hood, check the overall dimensions and the exact position of the electrical and water connections. It is recommended to position the appliance taking into account the space needed to carry out the electrical wiring and for easy maintenance. The appliance is not suited for flush mounting and for battery positioning. If the appliance is positioned near walls, furniture, etc., these have to be made of fire-proof material. **Otherwise, they have to be lined with non-combustible thermal material.** Comply with all fireprevention regulations.

## 2.4 REMOVING PROTECTIVE FILM ETC.

Remove the outer packing and dispose of it in compliance with the regulations in force in the country of installation.

1. Remove all the protective film from the external and internal walls of the appliance.
2. Remove any glue residue using a special solvent.
3. Remove all informative material from the inside, and take off all plastic packaging.

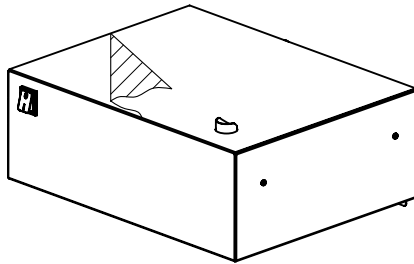

POCK

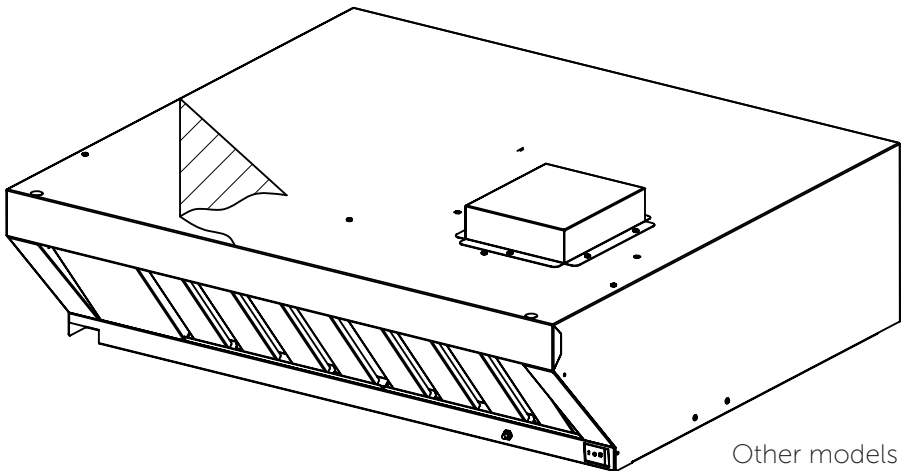

Other models

## 2.5 POSITIONING

During all installation and connection of the appliance, it is advisable to use special protective devices.

Inside the packaging of the appliance there are pins for fixing the hood on the oven. These pins must be mounted on the lid of the oven, using the special self-tapping screws, supplied.

To assemble the pins on the hood, please refer to fig. 1.

The suction hood must be positioned on top of the hood so that it is perpendicular to it, as illustrated in fig. 2.

**WARNING:** for the hoods in the RI range it is necessary to remove the preincision (fig.3), connecting the cable coming out of the hood after placing the supplied cable hole.

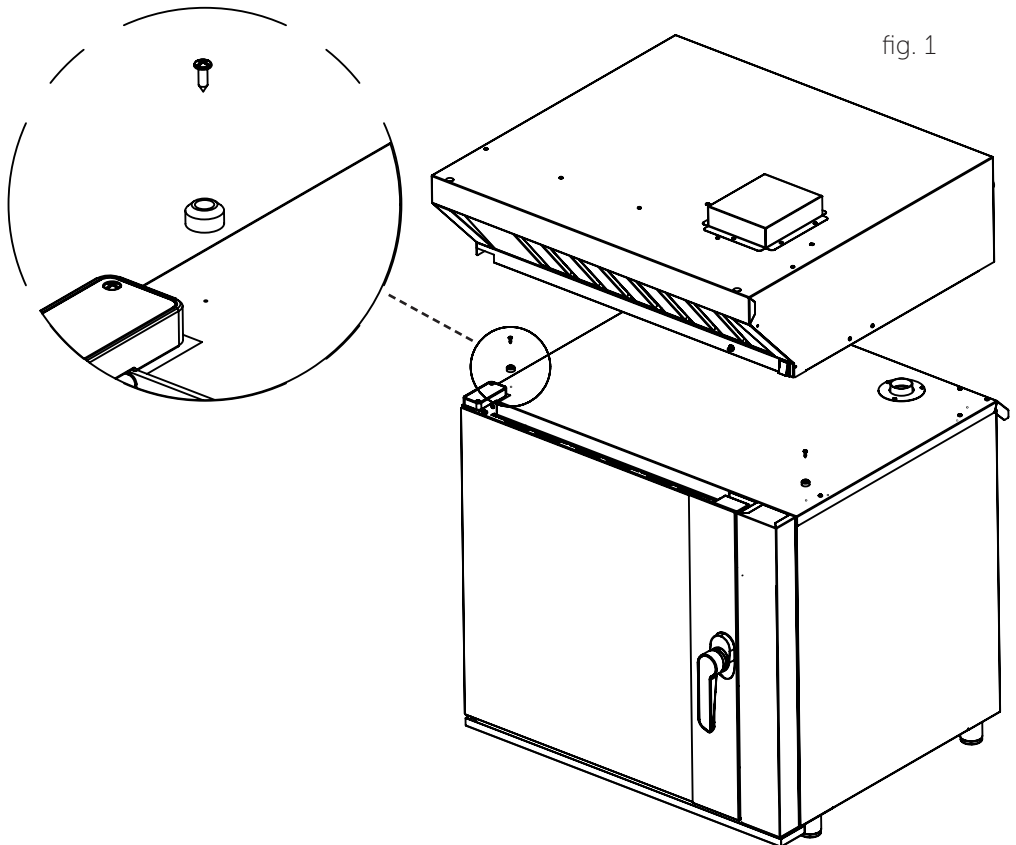

fig. 2

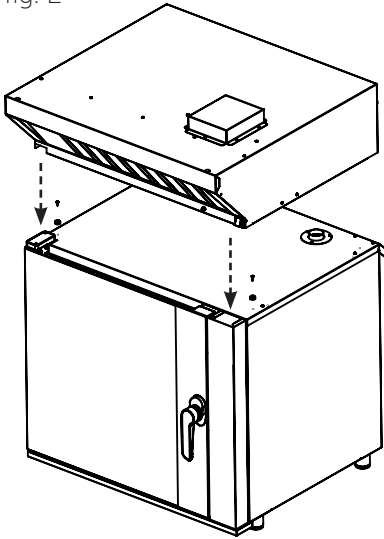
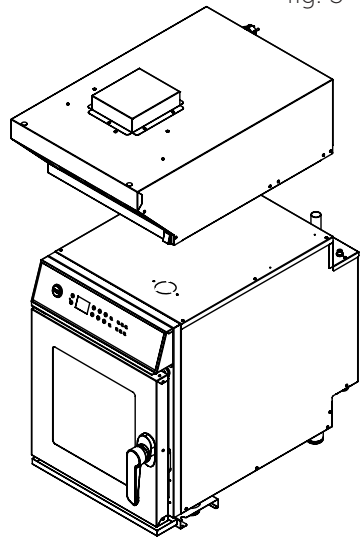
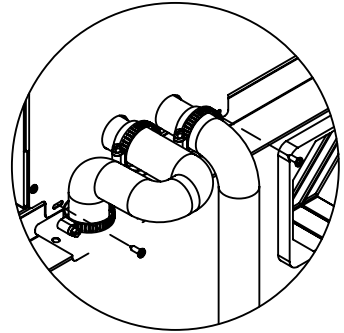
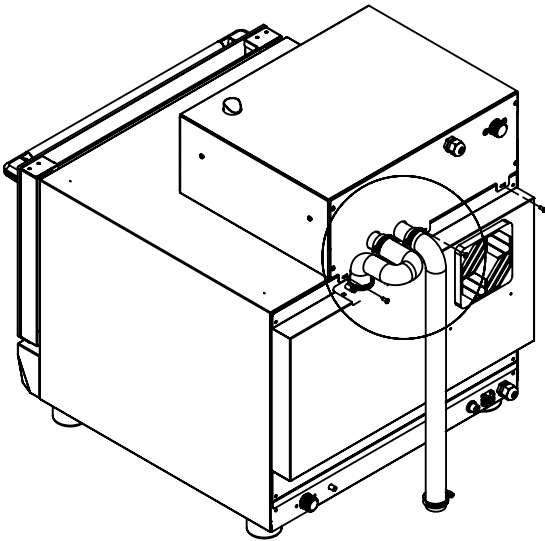

fig. 3



POCK



- Place the hood over the oven
- Connect the smoke outlet pipe with the two clamps supplied
- Fix the hood with the provided screws
- Connect the water drain pipe (not supplied)



# ELECTRICAL CONNECTION



## ATTENTION!



Mains connection must be carried out by a qualified and authorised technician according to national, international and local laws in the country where it is installed. Before connecting the mains supply, ensure that the frequency (....V) and voltage (....Hz) meet the requirements indicated on the Information Plate situated at the back of the appliance.

---

The appliance is equipped with a H07RN-F cable and Schuko plug (single-phase 220-240V). To electrically connect the suction hood to the mains, simply insert the plug into the appropriate socket (the socket must be adapted for the supplied plug and must withstand the voltage required by the appliance indicated on the Information Plate).

- The appliance must be positioned so that the plug is always accessible.
- The appliance comes with certified cable and plug; therefore, they must not be tampered with or modified.
- Place the cable in such a way that no point exceeds 50°C room temperature.

### 3.1 REPLACING THE POWER SUPPLY CABLE

The cable can only be replaced: this must be carried out by a qualified **authorised technician**. The replacement must be done using components (cable and plug) that have the same characteristics as the ones originally assembled on the appliance.

The earth wire must always be yellow green.

Access the terminal board of the appliance and replace the cable, complying with the connections of the conductor:

L = PHASE CONDUCTOR

N = NEUTRAL CONDUCTOR

 = EARTH CONDUCTOR

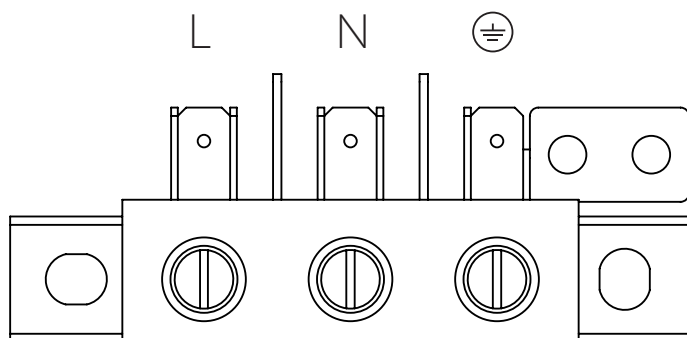

## ATTENTION!



An incorrect connection could lead to the terminal board overheating which could lead to a blow-out and electric shock.

The appliance must be connected directly to the mains power supply and must have an easily accessible switch upstream from it. It must be installed to the system according to the national, international and local laws in the country of installation.

This switch must have separate polarisation guaranteeing complete disconnection in accordance with the overvoltage III category. Correct earthing is obligatory and the earth wire must not be operated by the protection switch.

## 3.2 EQUIPOTENTIAL CONNECTION

This connection must be done between different appliances with the terminal marked by the symbol:



This terminal enables the connection of the Yellow/Green cable with a section between 2.5 and 10mm<sup>2</sup>.

The appliance must be included in an equipotential system whose efficiency has been duly verified according to the provisions of the laws in force.



# WATER CONNECTION



A stopcock and a mechanical filter with 120 Mesh filtering degree (not included) must be fitted between the water supply and the hood. At the rear, the hood has a 3/4 GAS-BSP inlet.



## ATTENTION!



Before connecting the appliance to the water supply, drain water to remove any residues of materials in the pipeline. The inlet water must have a pressure value between 150 (1.5 bar) and 200kPa (2 bar). If the inlet pressure values exceed 200kPa (2 bar), a pressure reducer must be installed at 200 kPa (2 bar).

---

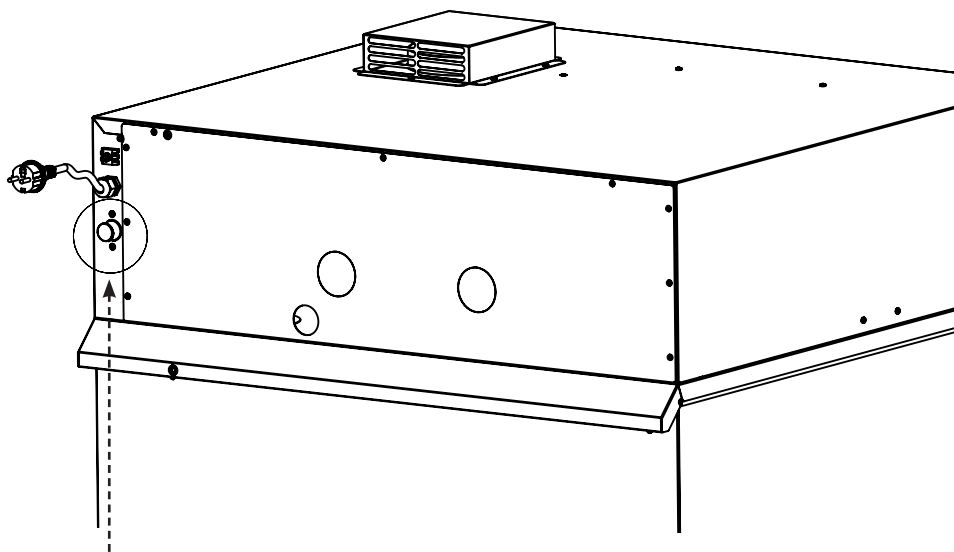

3/4 GAS-BSP



# FUME DISCHARGE CONNECTION

During cooking, hot fumes and other odors are produced that come out of the exhaust fumes of the cooking chamber.

The connection of the exhaust fume to the suction hood must be made using the material supplied, which includes:

- A. METAL STRAPS
- B. RED HOSE

To connect the exhaust, remove the sheet as shown in fig. 1.

fig. 1

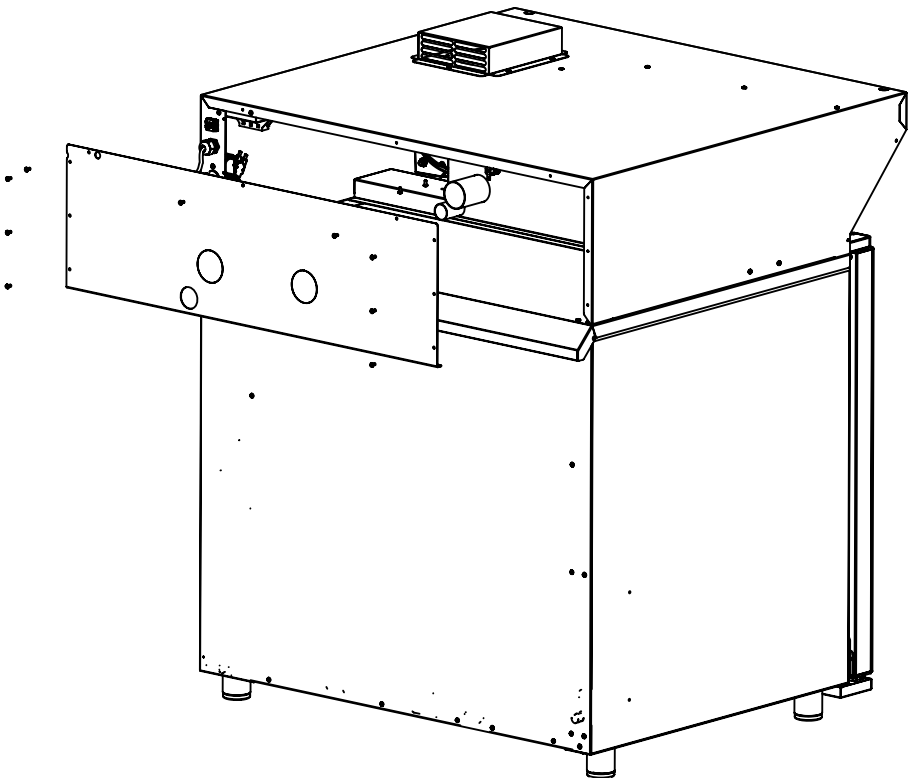

Then proceed with the connection of the red hose that can be fixed with the metal cable ties as shown in fig. 2.

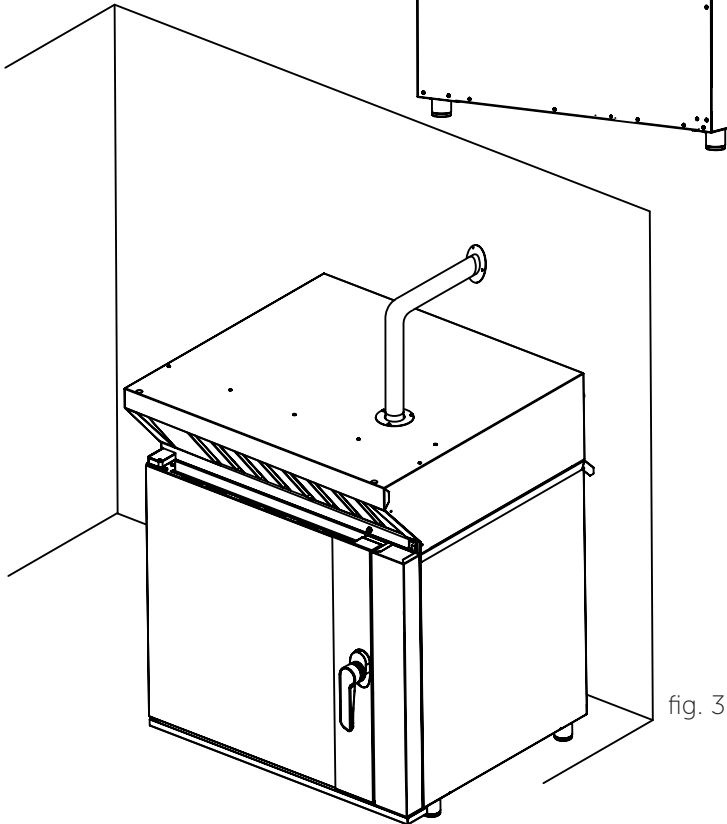
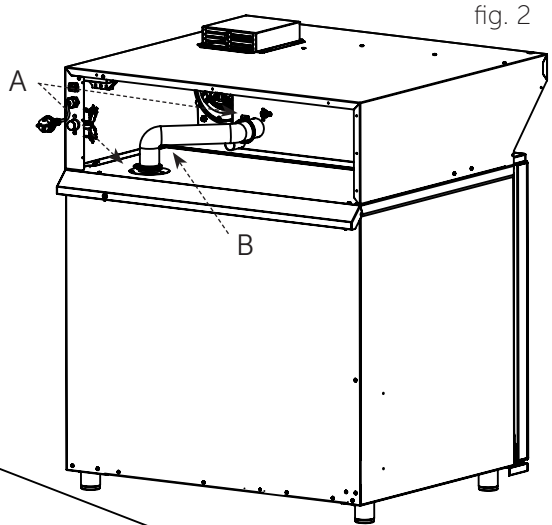

A pipe with a maximum length of 1.5 m and a maximum curve of radius 90 mm, a minimum diameter of 150 mm. (Fig.3) is required to make a correct connection to the fume exhaust of the hood, directly to the outside.

## 5.1 WATER DISCHARGE

Water discharged from the appliance can reach high temperatures (90°C). The pipes used to drain the water must be able to withstand such temperatures.

- The drain pipe is located in the rear part of the appliance and is to be connected with a rigid pipe or flexible hose and obligatorily conveyed to a sifted discharge; Its diameter must not be less than the diameter of the discharge coupling of the appliance.
- Avoid bends on the flexible pipes and rigid pipe elbows along the entire drain.
- The pipe must have a minimum 5% gradient along the section in order to ensure adequate outflow.
- The horizontal sections must not be longer than one metre.
- If several pieces of equipment or appliances are connected to the same pipe, make sure its size enables normal outflow without any issues.

Local regulations and standards must be complied with.

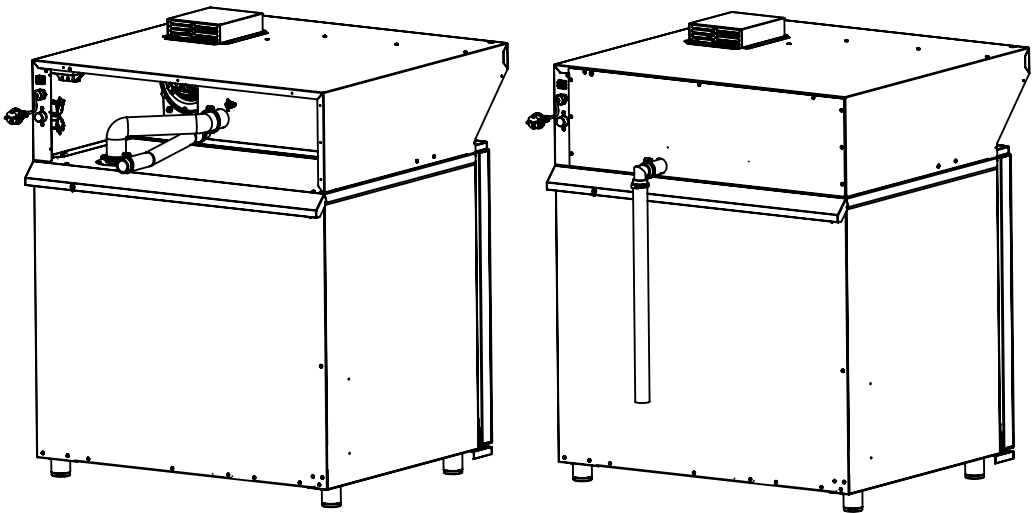

# INSTALLATION of FILTERS

## 6.1 FRONTAL FILTERS

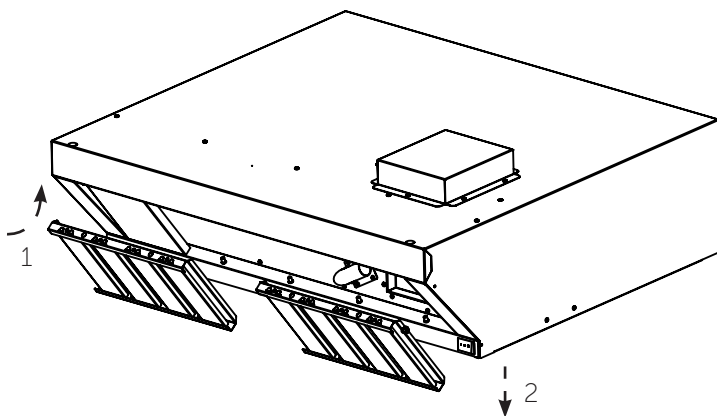

## 6.2 CARBON FILTERS

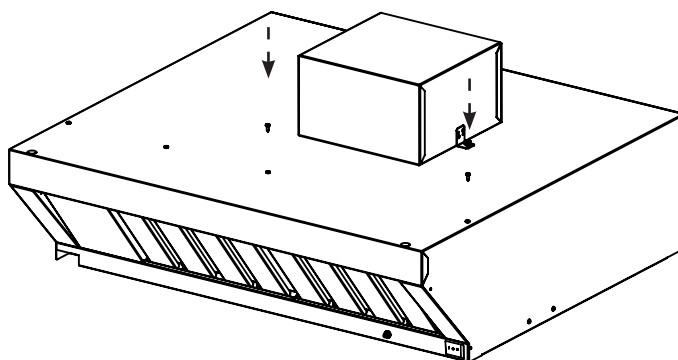

# INSTALLATION PLATE

In ovens, a plate is added to the door in conjunction with the front push-button for regulating the suction speed. When the door is opened, the hood works at maximum speed and allows you to suck in excess steam, while when closed, the suction speed is minimal.

Mount the plate as shown below.

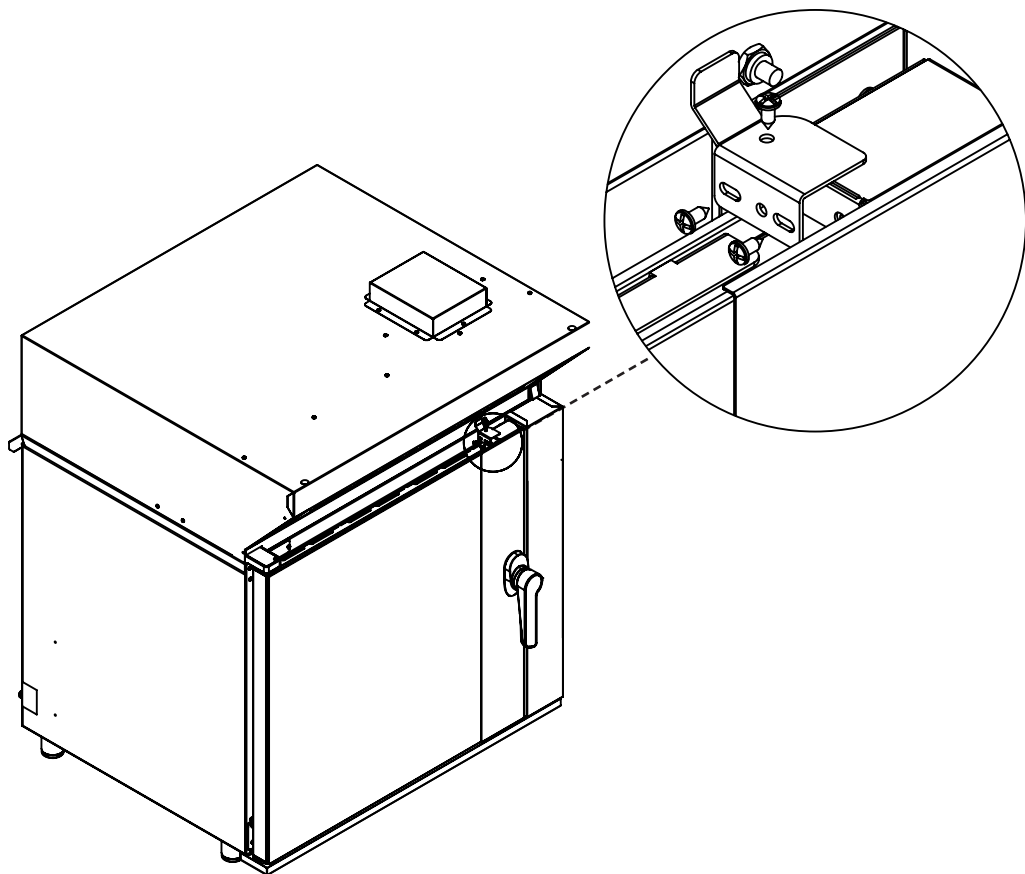

POSL

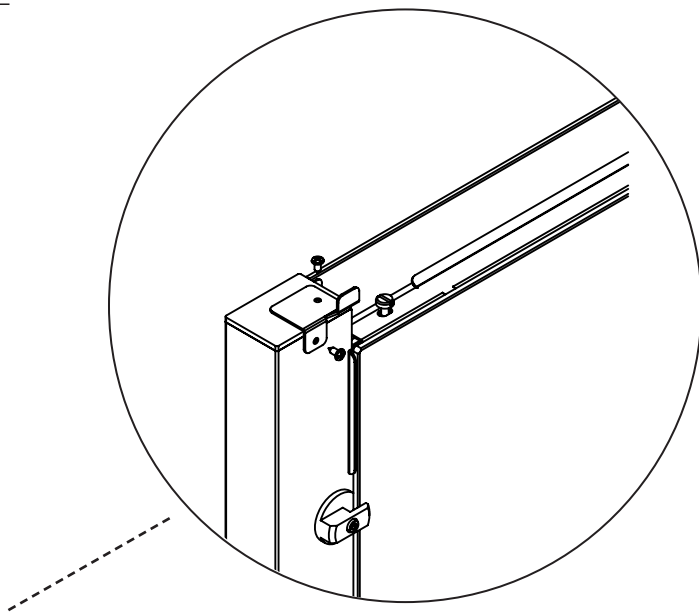

POSS

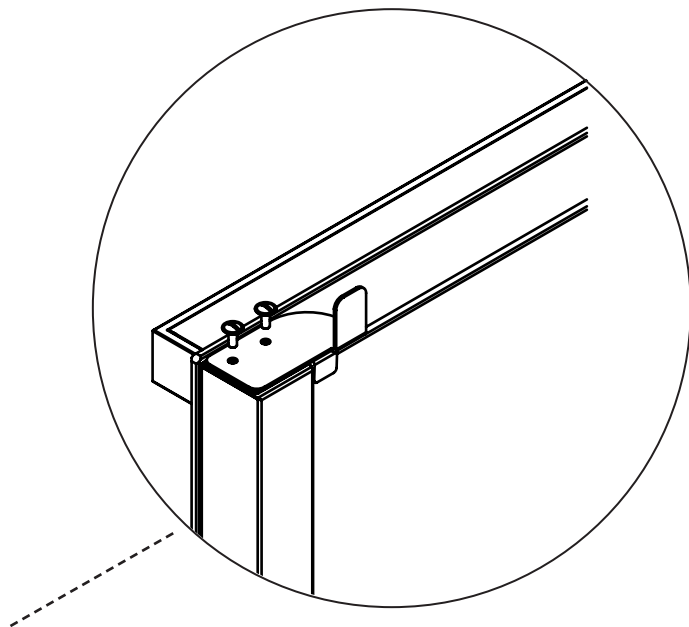

POSQ-POCP

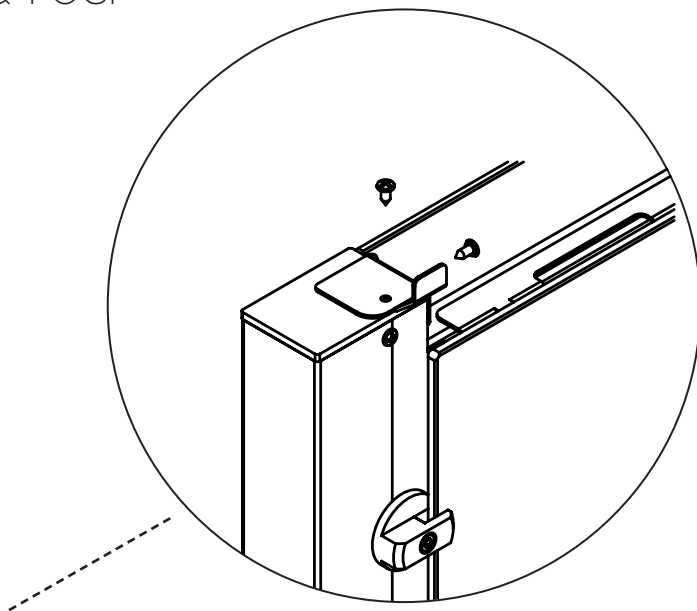

POSQ-POSG

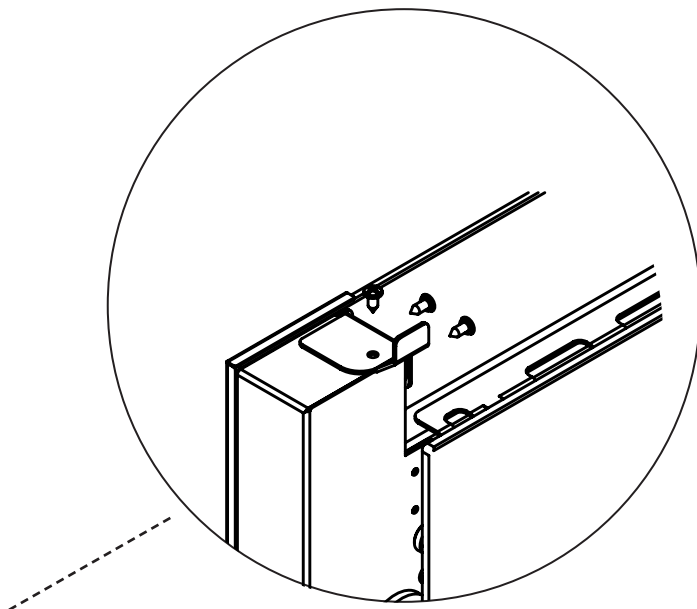

# INSTRUCTIONS

## for the USER

### 8.1 WARNINGS

Carefully read the following booklet as it provides safety and use instructions for the device. Carefully store it for future reference.

Incorrect installation, assistance, maintenance, use, cleaning, tampering with, or modifications can cause malfunctions, damage, and injuries.

### 8.2 CONTROLS FOR WATER HOODS



— **CONVECTION MODE:** the hood works using 50% less water. It is recommended for cooking that does not have a high amount of steam

○ **OFF MODE:** the hood is off

= **STEAM MODE:** the hood works using 100% water. It is recommended for cooking with a high amount of steam

### 8.2 CONTROLS FOR AIR HOODS

When the oven door is open, the hood is always in maximum suction mode.



— **MINIMUM EXTRACTION SPEED**

○ **OFF MODE:** the hood is off

= **MAXIMUM EXTRACTION SPEED**

At the end of cooking, it is recommended to open the oven door slowly, so that the hood can properly suck all the steam out of the cooking chamber.

# ORDINARY MAINTENANCE

All maintenance jobs must be carried out by qualified and authorised technical personnel. If necessary, cut out power to the appliance prior to carrying out any type of maintenance job, waiting for it to cool down first. It is recommended to subject the appliance to a complete periodical check (every 12 months) to be carried out by a skilled technician.

## 9.1 CLEANING THE OUTER SHELL

Before cleaning, disconnect the appliance from the power supply and wait until it has cooled down completely.



**ATTENTION!**



Never clean the device with water jets or pressurised steam.

Clean the walls of the suction hood using a damp cloth or sponge. Use only cleaning products specifically intended for steel, in order to avoid damaging the steel surfaces of the hood.

## 9.2 CLEANING THE FILTERS

The filters are removable and must be washed periodically (depending on the use) in order to ensure proper operation of the appliance over time. The filters must be washed in the dishwasher.

Carbon filter removal

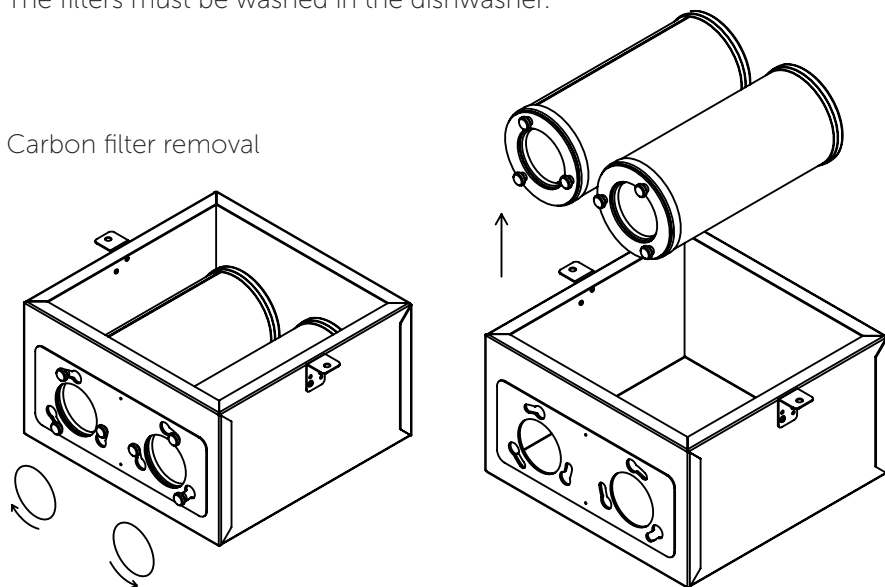

## Frontal filter removal

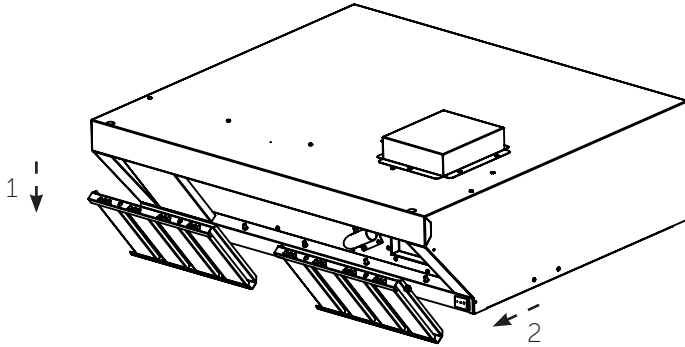

# MAINTENANCE in CASE of BREAKAGE

In case of breakage, disconnect the appliance from the mains.  
Before ringing the Customer Service, check the chart below.

The hood does not turn on	Lack of power supply	Check input voltage in terminal block	If absent, reset input voltage
		Check input voltage at ON/OFF button	If absent, check wiring
	ON/OFF button not working	Check ON/OFF button operation	If not working, replace button
The suction motor does not work	ON/OFF button not working	Check ON/OFF button operation	If not working, replace button
	Lack of engine power	Check input voltage to the motor	If absent, check wiring
	Engine not working	Check input voltage to the motor	If present, replace engine
Suction speed does not increase when oven door is opened (water hoods only)	Door plate absent or not correctly positioned	Check that the plate on the port presses the micro switch on the hood correctly	If not, reposition plate
	Micro switch not working	Check micro switch operation	If it does not work, replace the micro switch

Fumes are not condensed properly (with master switch in position 2)	Incorrect application	Check with the supplier whether the hood is suitable for the application	-
	Air hood: the motor works at minimum speed	Check that the maximum motor speed corresponds to position 2 of the master switch	In case of errors, contact the supplier
	Water hood: no or insufficient water	Check incoming water supply	Connect the hood to the water supply according to the instructions in the manual
		Check cleaning filter solenoid valve inlet	Disconnect the solenoid valve and clean the filter inside
		Check operation thermostat activation solenoid valves	If it does not work, replace the thermostat
		Check that with the switch in position 2 (and the thermostat closed) both solenoid valves are powered	In case of errors, contact the supplier
		Check that when you power up the elettrovalvole open properly	If not, replace the solenoid valve

If the problem persists, we advise you to contact the retailer or manufacturer asking for Customer Service, specifying the problem and supplying the appliance code (Art.) and serial number (Ser. no.). This information is provided on the DATA LABEL on the back of the machine.

## 10.1 SPARE PARTS

Use only authorised parts for product repair. All interventions must be carried out by authorised and specialist technical personnel. Contact Customer Service to request spare parts.



GGM Gastro International GmbH  
Weinerpark 16  
D-48607 Ochtrup

[www.ggmgastro.com](http://www.ggmgastro.com)

[info@ggmgastro.com](mailto:info@ggmgastro.com)

+49 2553 7220 0