

# Hybrid Hood with Electrostatic Ecology Unit **Users' Manual**

# 1. Safety requirements



Environmental Requirements

A.Ambient Temperature: +10 ~ +40°C

B.Humidity: 20 ~ 90%

C.Height above sea level: < 1000m

D.Nature of waste gas to be processed: non-combustible, non-explosive, non-corrosive and non-volatile gas with a temperature of <60°C



Danger

The specified hazard will cause damage to persons and property!



Requirements

The requirements should be 100% met to avoid damage to device or human body

## 2. Structure

### 2.1 Illustration

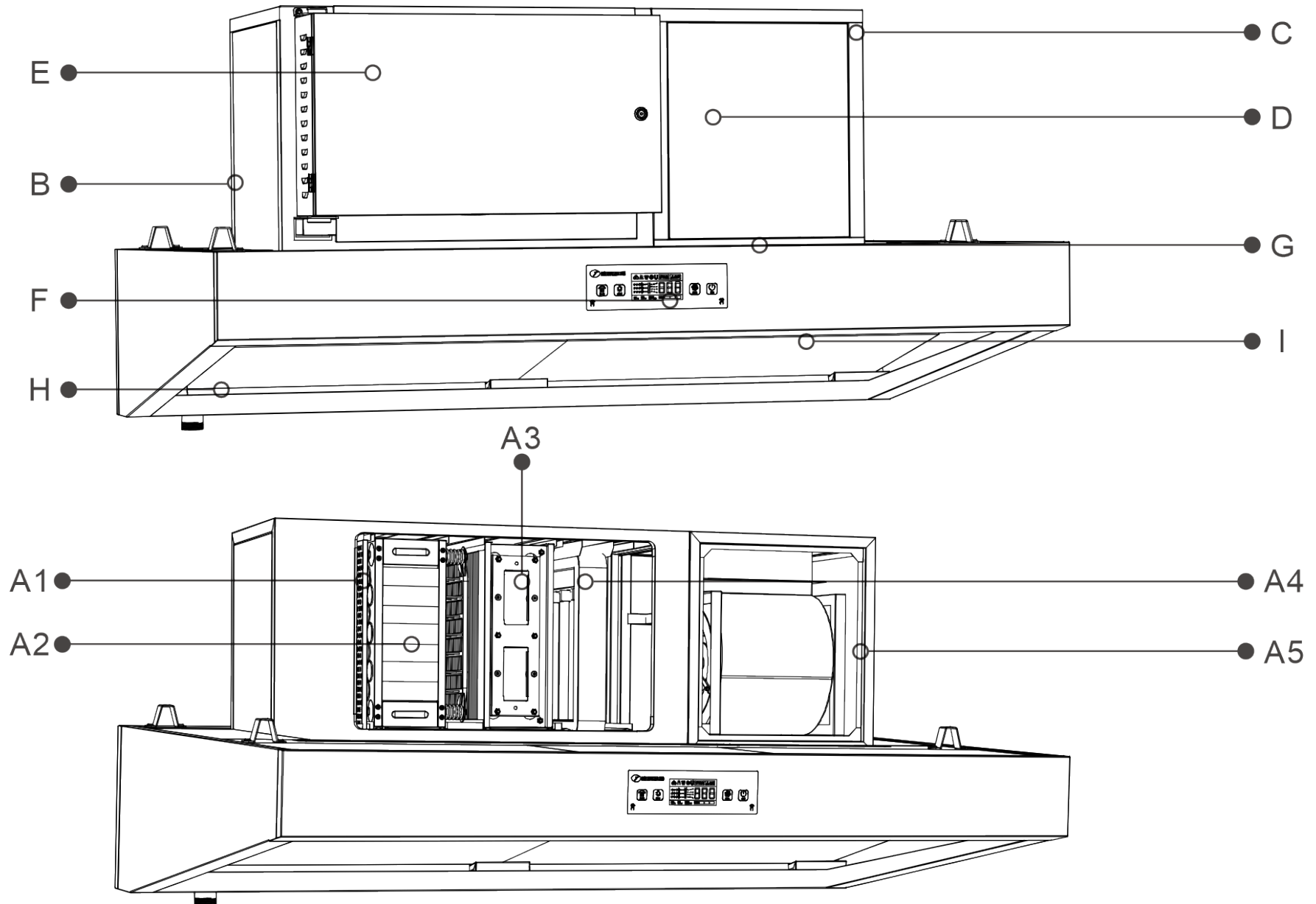

# 2. Structure

## 2.2 Description

No.	Name	Function description
A1	Pre-filtration mesh	Stop large particles & evenly divide exhaust airflow
A2	High-efficiency filtration section	Primary oil mist Collection
A3	Secondary filtration section	Advanced oil mist Collection
A4	UV device (optional)	For smell control
A5	Exhaust fan	For Exhaust air extraction
B	Lifting Lug	For fixing of hood
C	Access door of fan	For exhaust fan & UV lamp overhaul
D	Access door of filter cell	For filter cell maintenance
E	Power Pack	KLEAN Patented Power Pack
F	Explosion-proof LED	Lighting
G	Control Panel	For device control and running status display
H	Oil outlet	For oil drainage
I	Water/Oil Baffle	Stop oil/water from dropping

## 2. Structure

### 2.3 Configuration

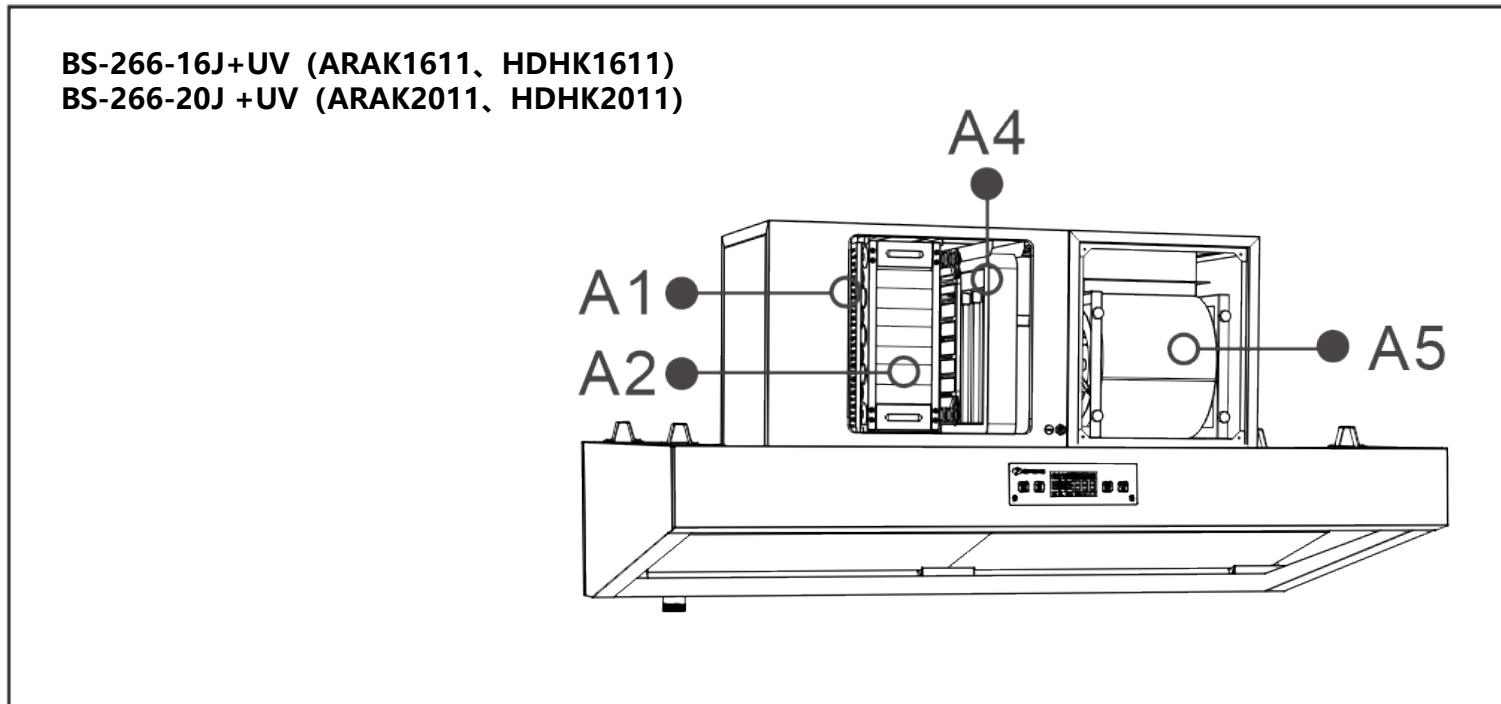

# 3. Assembly instruction

## 3.1 Parts assembly

01

take out filter cell & UV filter

air outlet direction is adjustable

connect ESP mainbody and blower box with screws

02

② put the mainbody+blower housing on the top of hood

① fix infill board (Press firmly into position)

③ protect the bottom of hood from any scratches

03

lift the hood to tighten screws

tighten 8 screws as marked here

04

the mainbody shall be lifted horizontally

lifting lugs shall be fixed at 4 corners of hood (lifting lugs are in the package)

05

put filter cell back into the casing

06

fix baffle plate

# 3. Assembly instruction

## 3.2 Wiring (touch-screen control panel)

Notes:

- ① LED wire
- ② UV wire
- ③ Blower wire
- ④ Screen wire

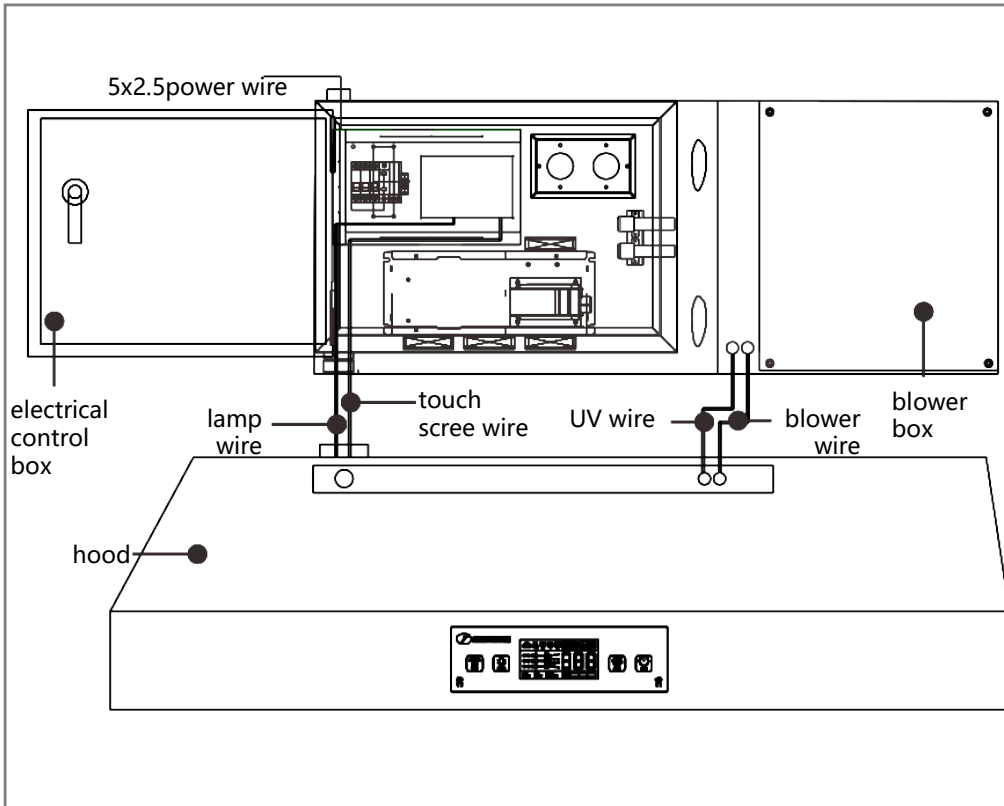

external diagram

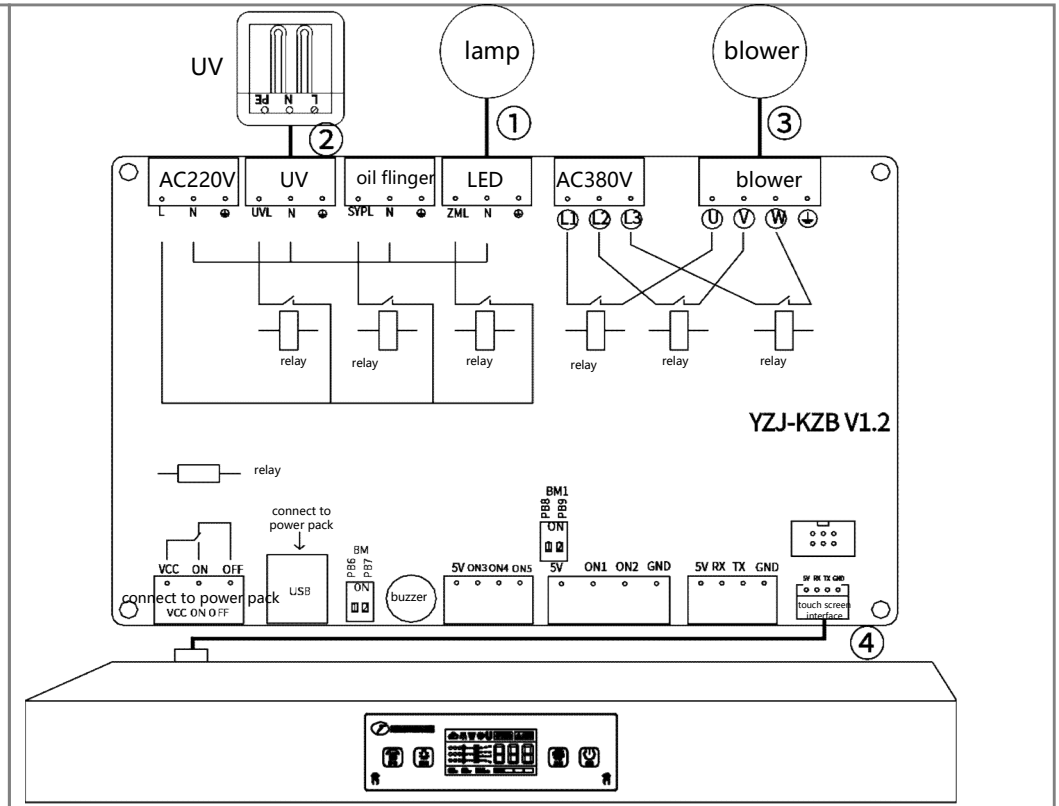

internal diagram

### 3. Assembly instruction

#### 3.2 Wiring (button-type control panel)

Notes:

- ① LED wire
- ② UV wire
- ③ Blower wire
- ④ button wire
- ⑤ screen wire

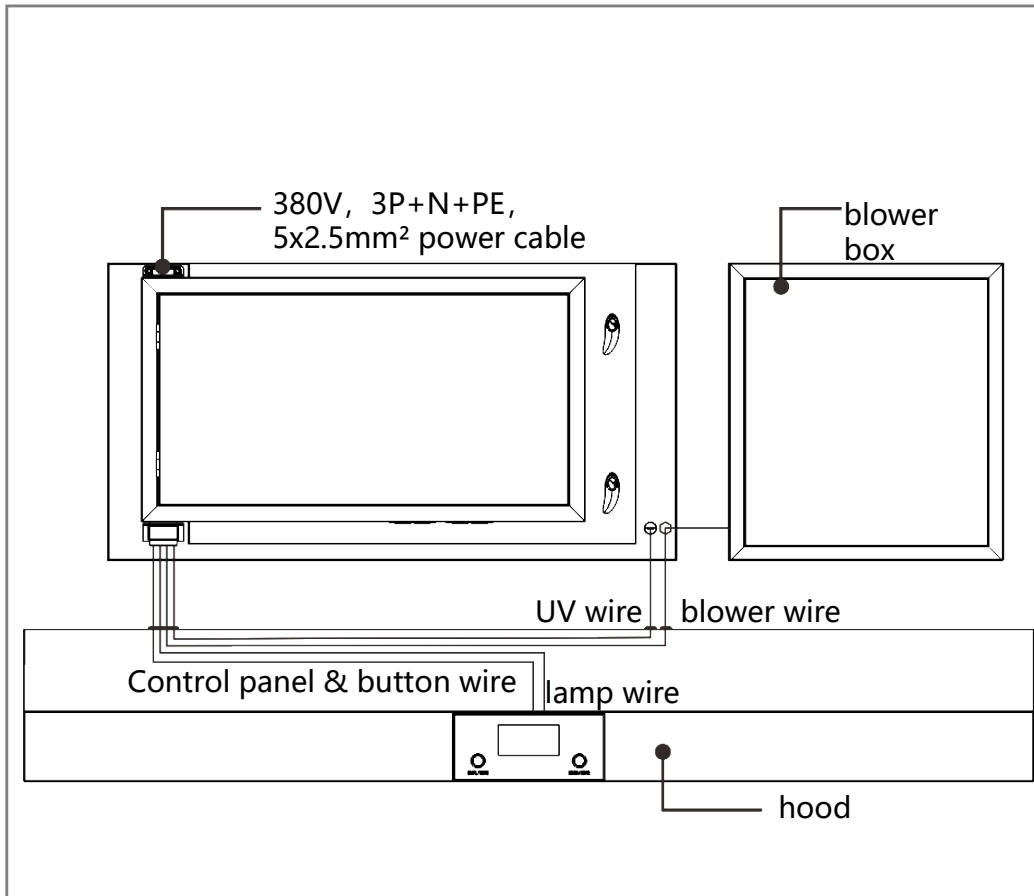

external diagram

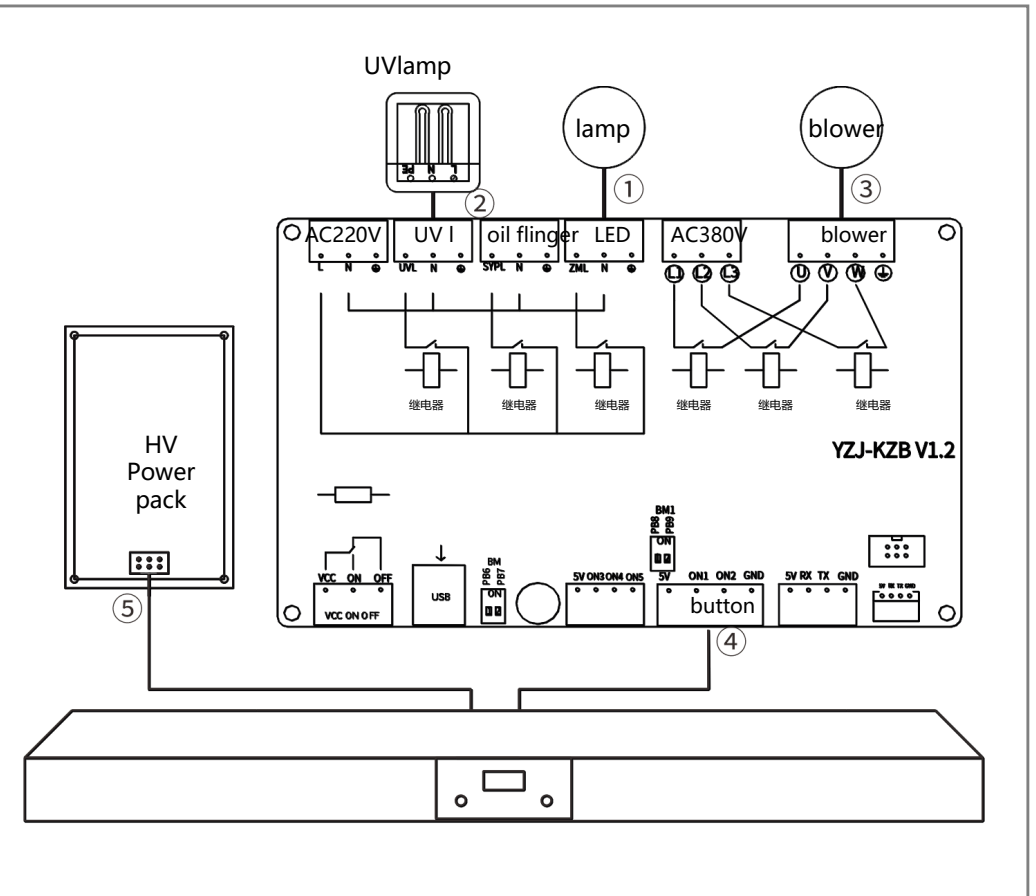

internal diagram

## 3. Assembly instruction

### 3.3 lifting

There are four lifting lugs on the four corners of the upper edge of the casing that can be used to fix the ESP to the ceiling through  $\phi$  12mm sus wire (Figure 3-1). Users can also replace the lifting lugs with other lifting and fixing apparatus. Make sure that fixation is firm and secure. The load capacity of lifting lug is supposed to be identical so that the surface of the ESP block inside the hood assembly would be kept vertical to the cooking surface being ventilated (Figure 3-1).

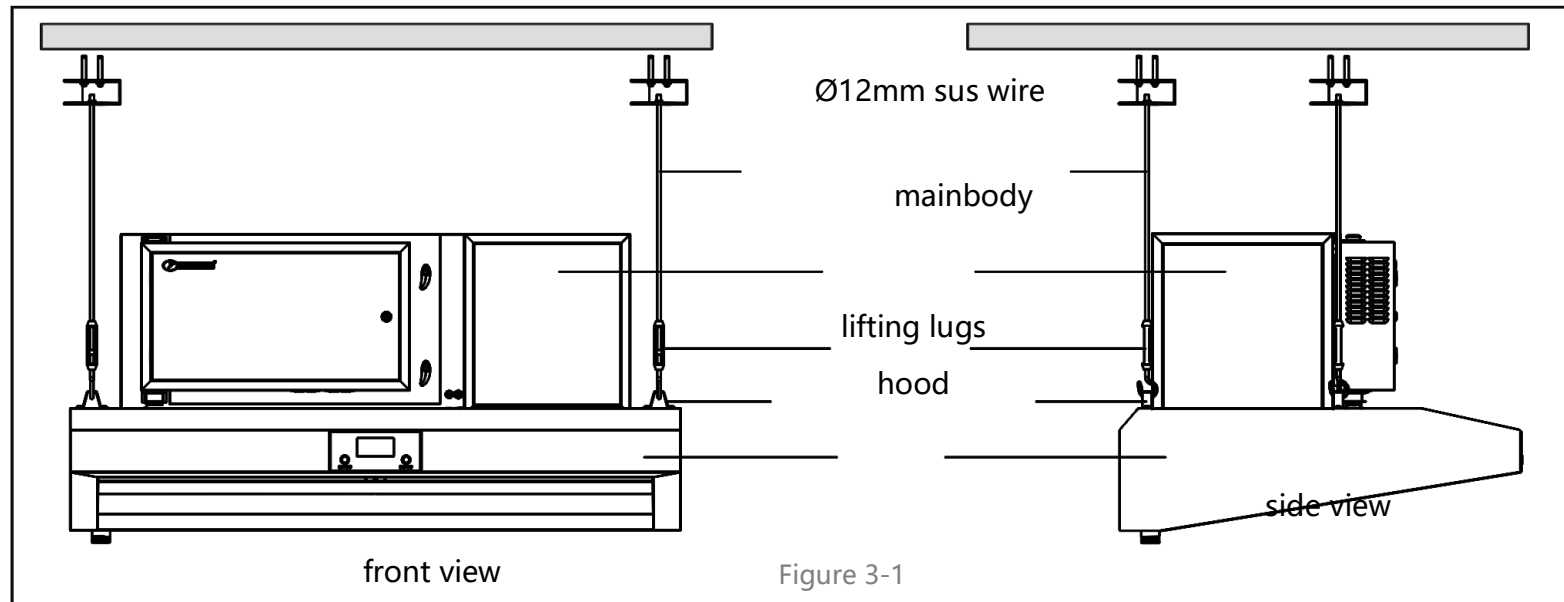

Figure 3-1

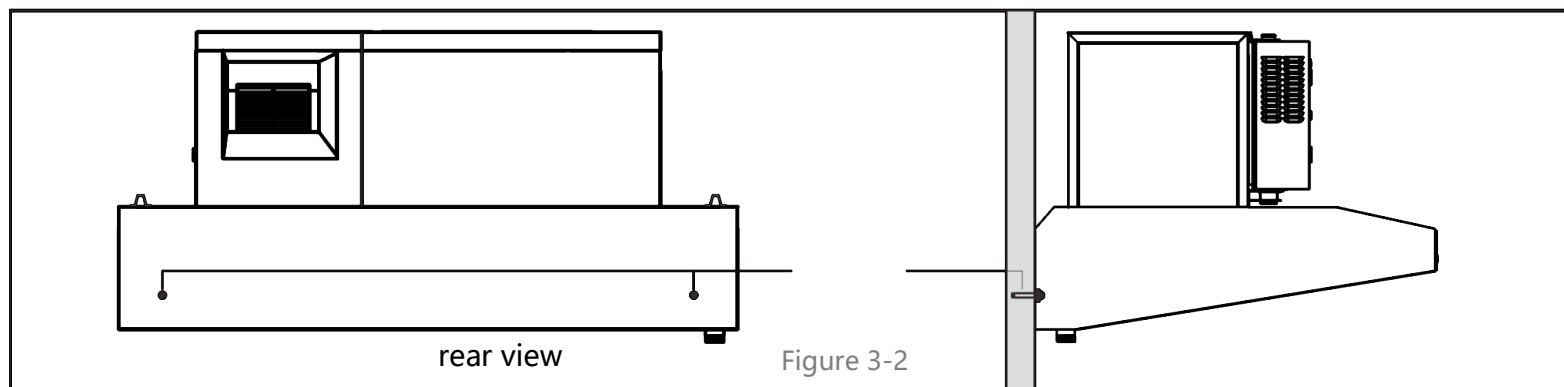

Figure 3-2

## 3. Installation



The installation design of the ESP should be handled by qualified professionals. Do not power up the ESP before the completion of the installation of the system. There is extremely high voltage generated inside ESP when it is in full operation. Do not install the ESP near any facility that produces flammable or explosive gases. An electrical leakage protection device should be installed between the main power supply line and the power source to avoid the leakage risk. The ground lead should be reliable and the resistance should be less than  $2\Omega$ . The surface of the ESP block inside the hood assembly should be kept vertical to the cooking surface being ventilated. The fixation of the hood assembly should be firm and secure.

### 3.4 air outlet direction

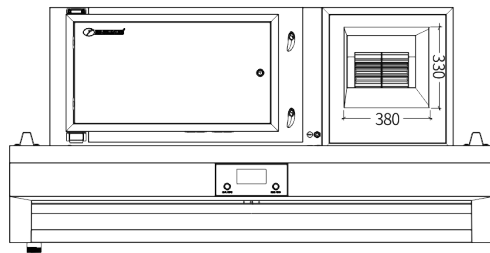

figure 3-3 air outlet at front side

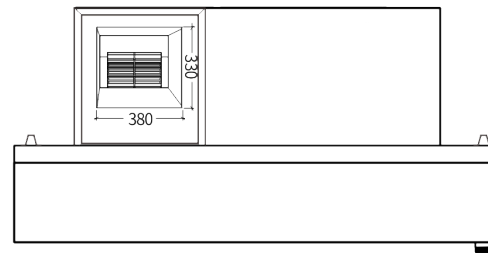

figure 3-4 air outlet at back side

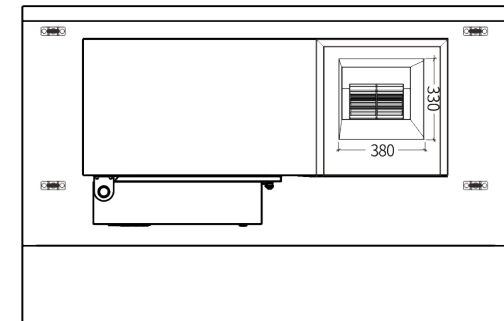

figure 3-5 air outlet on top



·There shall be soft joint between air pipe and hood to avoid vibration

## 3. Installation

### 3.5 Installation requirements



#### Requirements

The hood should be fixed right above the cooking surface to ensure good air extraction.

The distance between ground and hood shall not be less than 1.9 meter.

Air pipe size shall be at least 300×400mm. Velocity inside main pipe shall not be higher than 8m/s. If the air pipe between hood and air outlet is longer than 5 meter or the elbow is more than 2 or more than two pcs of hood are installed in line, please prepare additional fan.

Please install fire damper based on local fire control policy.

To reduce the weight when lifting, you can take out filter cells and put them back later.

# 3. Installation

## 3.5 Installation drawing

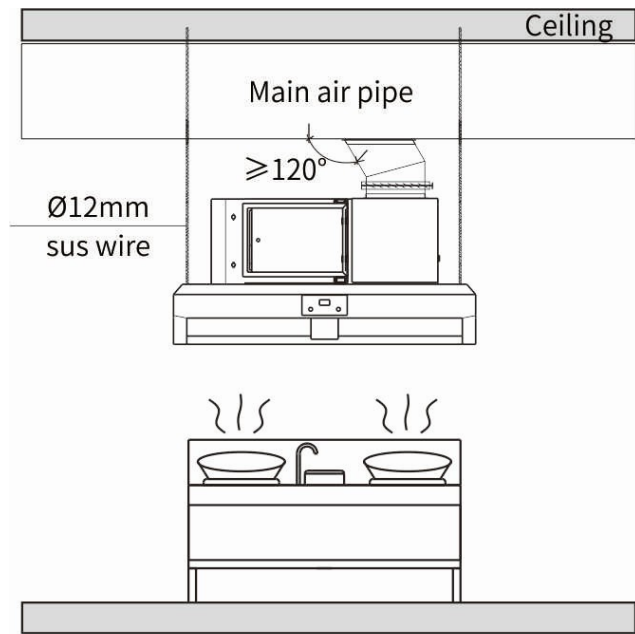

Front View

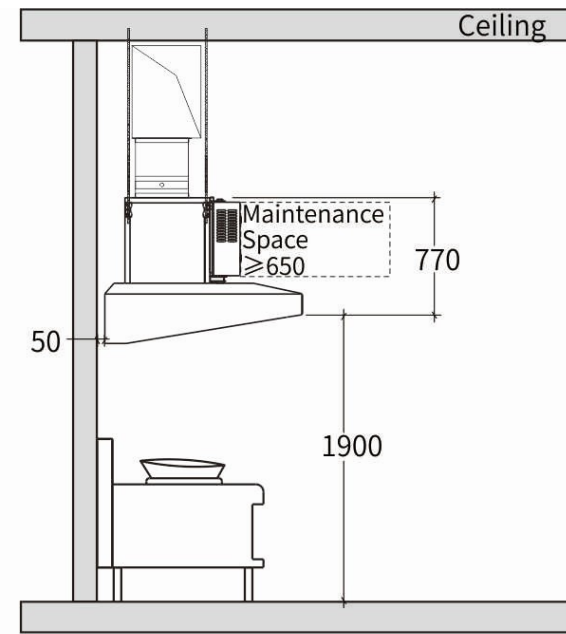

Side View

# 3. Installation

## 3.6 Wind shield



Requirements

·Metal wind shield should be set up for hood which is not installed against wall to prevent oil mist escaping from hood.

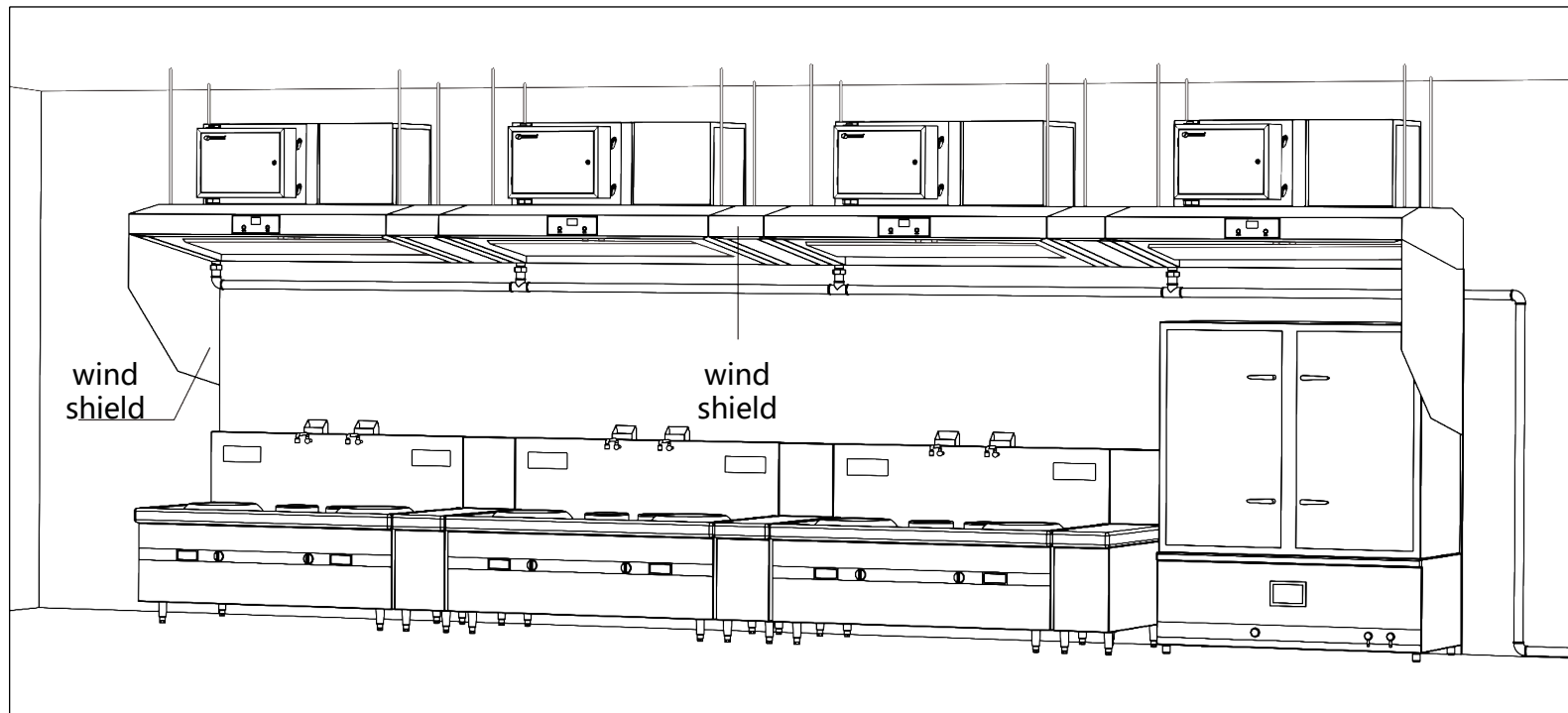

figure 3-6

## 3. Installation

### 3.7 Power cable connection

please input 3P+N+PE (2.5mm<sup>2</sup>)

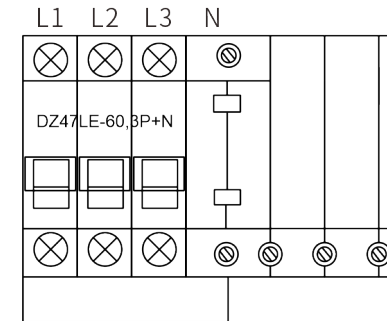

figure 3-7

### 3.8 Debugging

#### Power supply inspection:

Before power-up, please use the volt meter to check if the power supply meets the specifications indicated on the nameplates of the ESP and the exhaust fan, and make sure that the earth resistance of the ground lead is less than  $2\Omega$ .

#### Airflow volume adjustment

Power up, switch on the exhaust fan and make sure that its rotation direction is correct. Adjust the airflow rate to the extent that the actual airflow rate through each ESP is equal to or smaller than the rated exhaust capacity of ESP by use of airflow rate measuring device and airflow rate controlling device. Meanwhile, check if there is any air leakage from the ducts and take leak-mending measures when necessary.

# 4. Operation

## 4.1 Notice



danger

·There is high voltage inside a running ESP. Please cut power before opening access doors.  
Press fan button prior to pressing ESP/UV button

## 4.2 Digital panel (for option)

when ESP is running, it shows working current (A...)/fault code (C...).

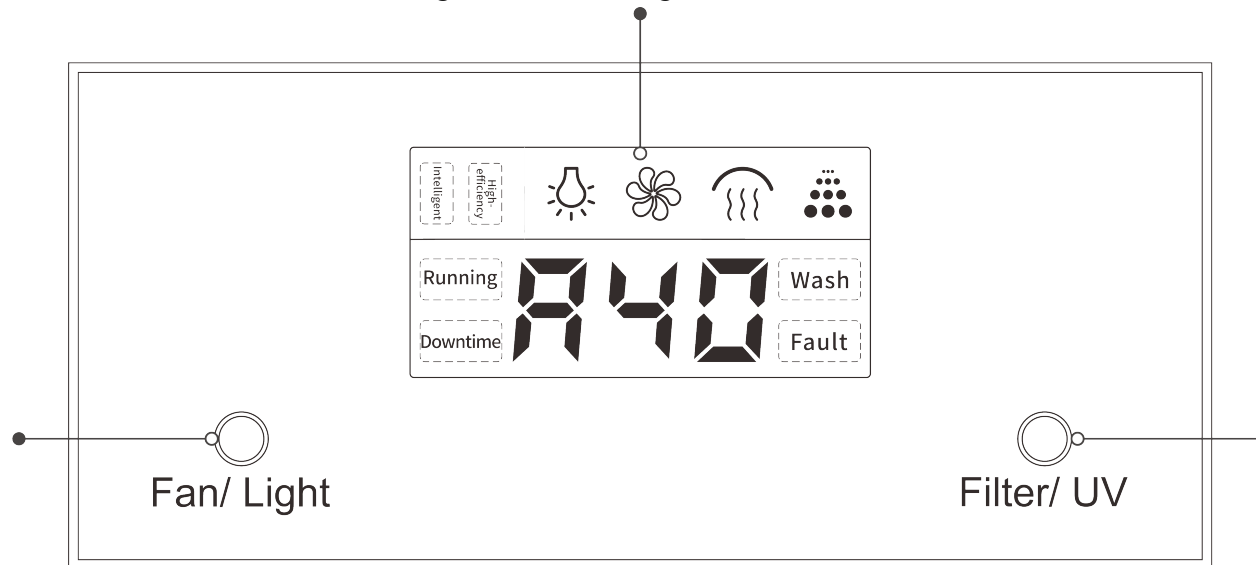

Requirements

·how to start: presse fan button first and ESP button later.  
·how to stop: Press ESP button first and fan button later.

# 5. Maintenance

## 5.1 Notice



danger

There will still be residual current running inside power box even if the equipment is power off. Users should switch off the general power supply before carrying out any maintenance or repair work on the ESP.

Use screwdriver to release residual current inside the filter cell, as shown on the right, after opening the overhaul door of ESP. To do that, users should hold the insulation section of the screwdriver, then use the metallic section of screwdriver to connect the anode with cathode.

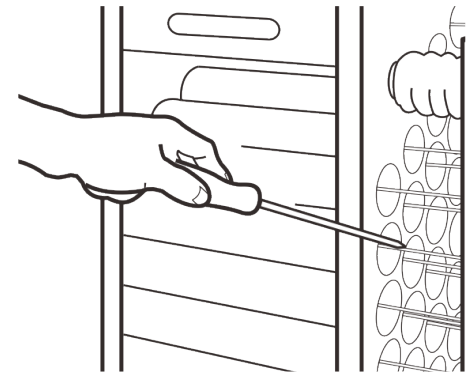

## 5.2 Maintenance



Requirements

Operators should wear goggles, gloves, helmet and protective clothing to protect the skin against the harm of alkalinity detergent.

# 5. Maintenance

## 5.3 Maintenance schedule

Users should keep regular and effective maintenance and inspection on the ESP so as to ensure its long-term stable performance and high purification efficiency.

Period	Items
Daily	a. Keep the ESP surface clean
	b. Check if the drainage outlet can work normally.
	c. Check if there is any leakage on the hose or air-vent.
Weekly	a. Wash Water & Grease Baffle
Monthly	a. Wash feed-through insulator
	b. Clean the grease deposits inside the hood
	c. Wash filter cells & UV lamps

# 5. Maintenance

## 5.4 Filter cell cleaning

**01** Prepare below tools before cleaning

water tank  
caustic soda (soda:water 1:25)  
brush  
ionizer rectifier  
high-pressure water gun  
protective glasses  
screwdriver  
protective gloves

**02** Switch off power supply prior to opening access door

Use screwdriver to release residual current inside the filter cell prior to taking out filter cells.

**03** Always wear protective glasses and gloves when handling caustic soda solution (soda: water=1:25) with temperature higher than 75C

Perforated filter should also be soaked.  
Soak filter cell for 15~20 mins)

**04** Wash filter cells including insulators with high-pressure water gun

Wipe out grease on surface of insulators with dust cloth.

# 5. Maintenance

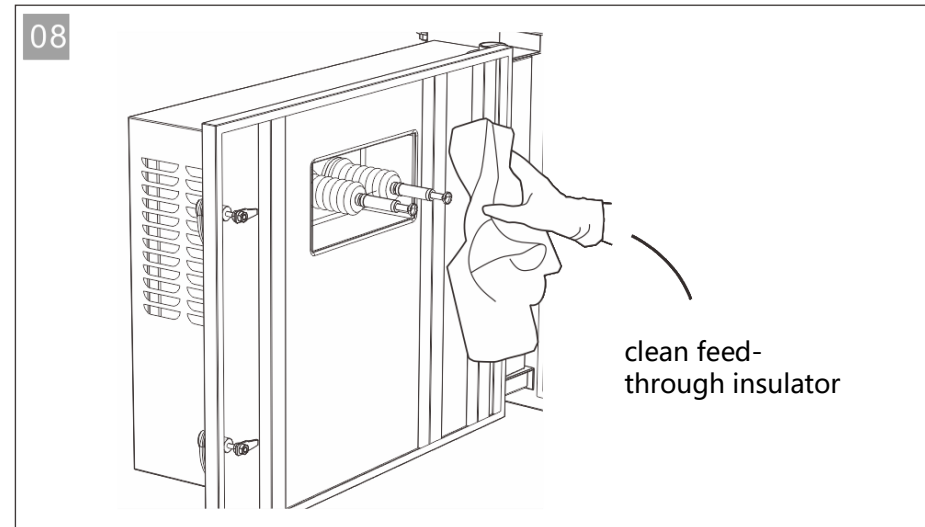
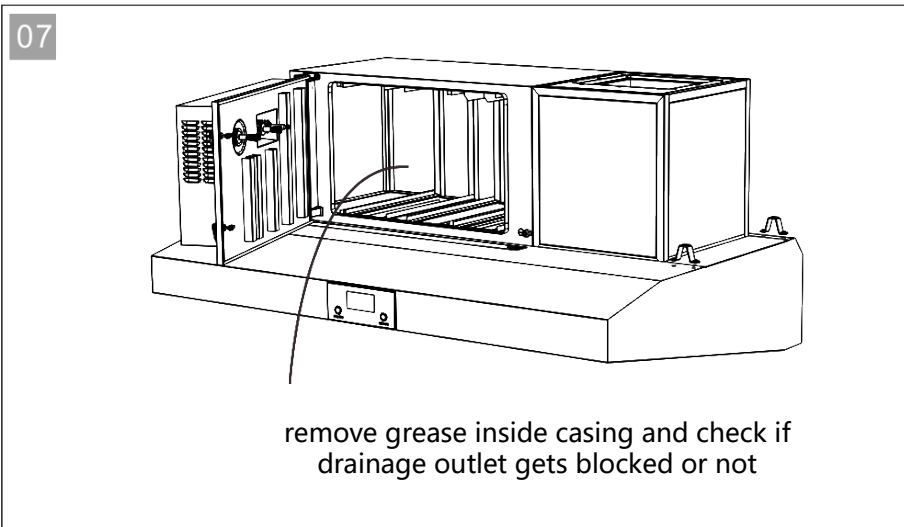
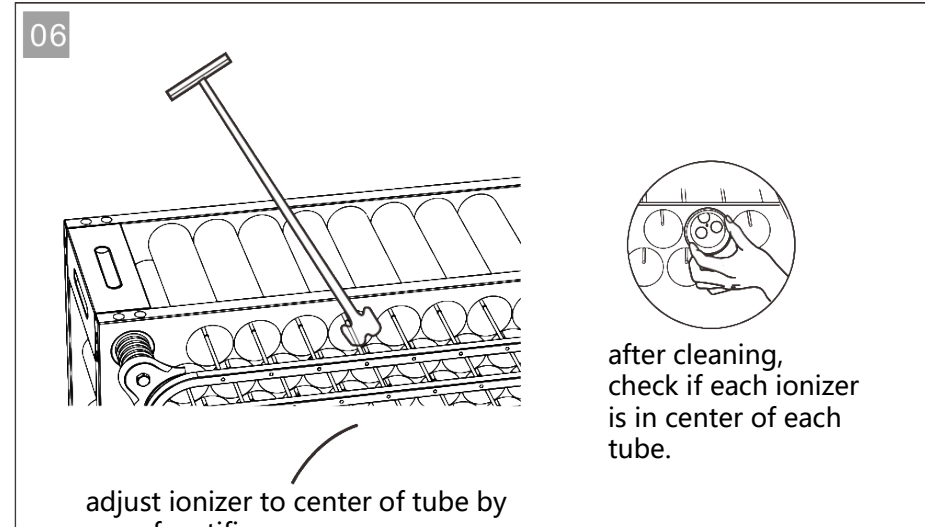
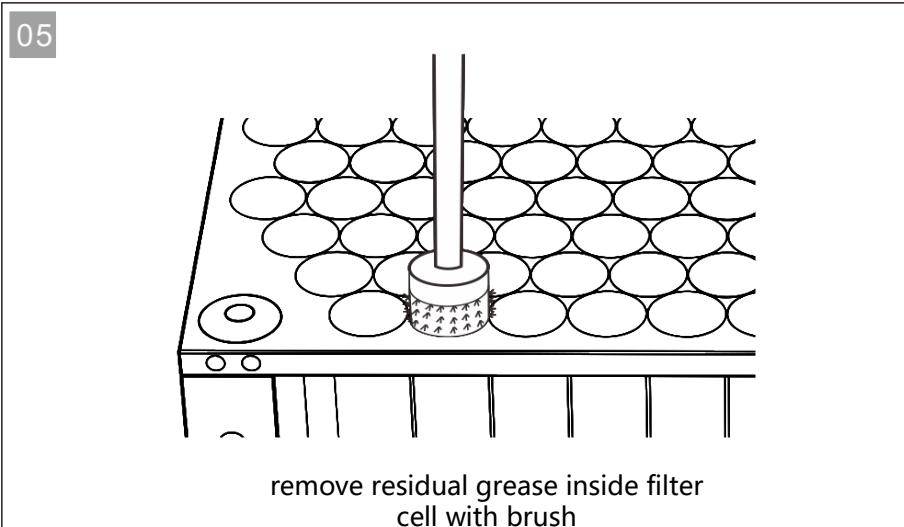

# 5. Maintenance

Cracked insulators should be replaced in time.

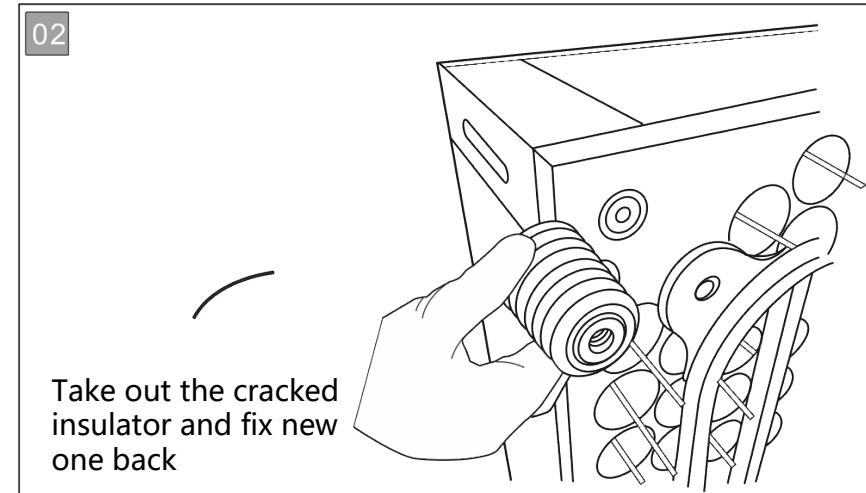
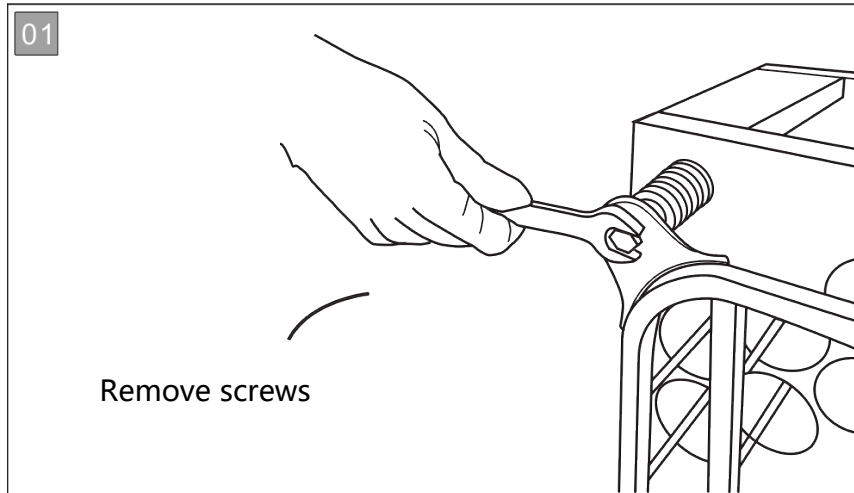

Requirements

The filter cells must be held steady to avoid possible personal injury caused by falling down during moving tableting.

Insulators must be rinsed with clean water and wiped dry, since the residual electrolyte of a strong alkaline solution on the surface of the insulators would cause surface flashover, which would influence the proper function of the ESP and posing safety challenges to the system.

# 5. Maintenance

## Grease/water baffle cleaning

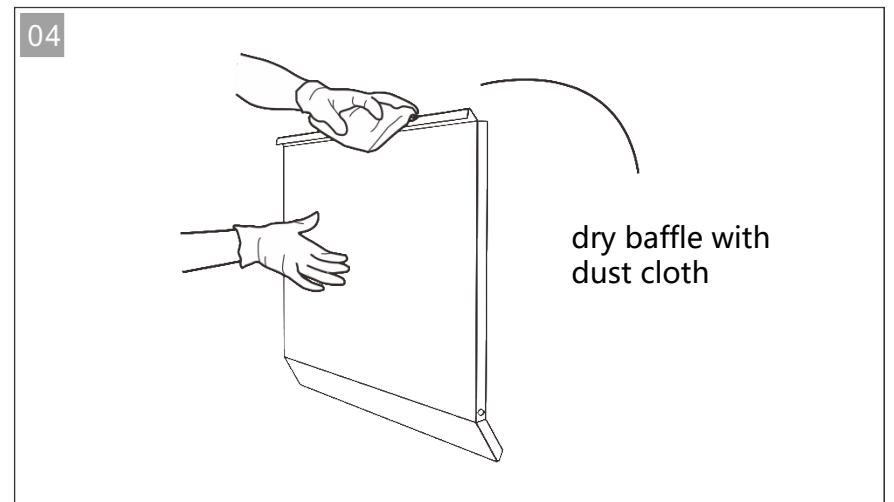
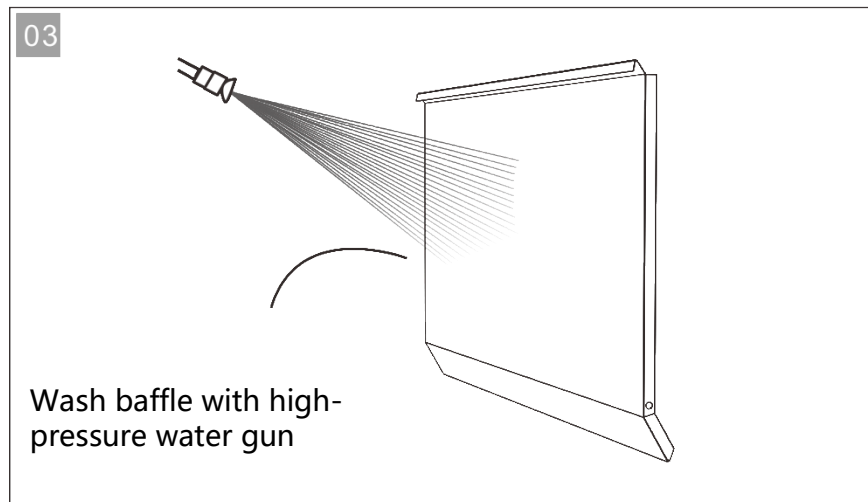
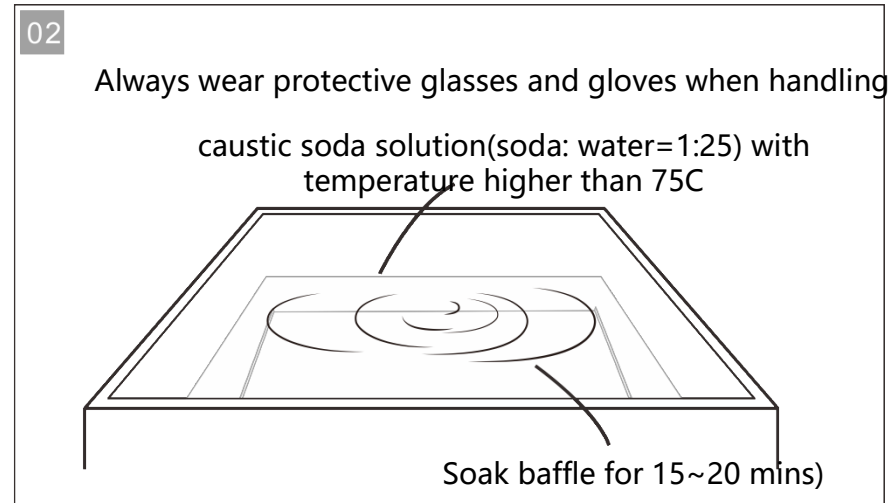
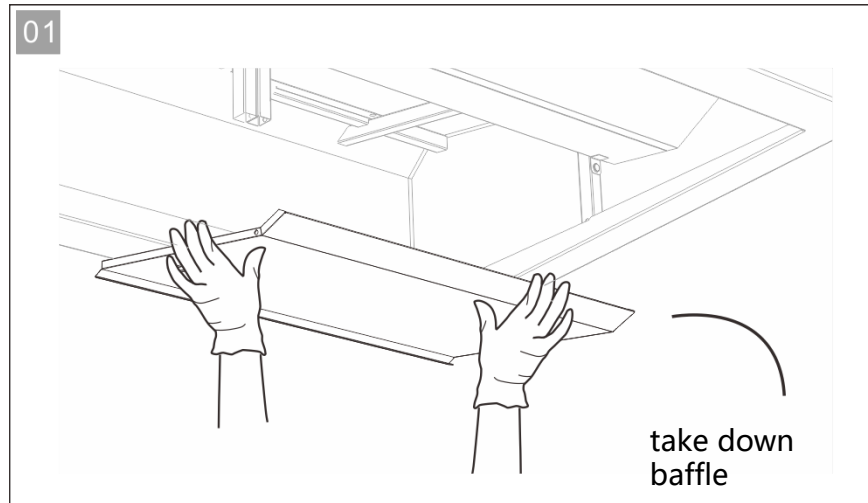

# 5. Maintenance

## UV lamp cleaning



Ultraviolet rays can cause damage to organic cells. Please do not keep our skin or eyes exposed directly to UV.

Pay particular attention to radiation damage on Eye conjunctiva. Injured by radiation, eyes will be red and feel stabbing pain. Please consult a doctor immediately.

Prevention method: Avoid facing light source directly; wear special black glasses or UV protective mask, or use common glass and hard paper as protective mask in some special cases. Do not use protective mask made of quartz glass, as the UV penetration efficiency of quartz glass is 80%. While UV almost can not penetrate common glass, so it will be effective in preventing us from damage from UV.

·The protective casing of UV lamp is made of quartz glasses, which require regular cleaning. As dust & grease deposit might influence penetration of UV and then lower odor elimination efficiency. Apply alcohol wipes or gauze to wipe it, or clean it with detergent. After cleaning, please wipe and dry it.

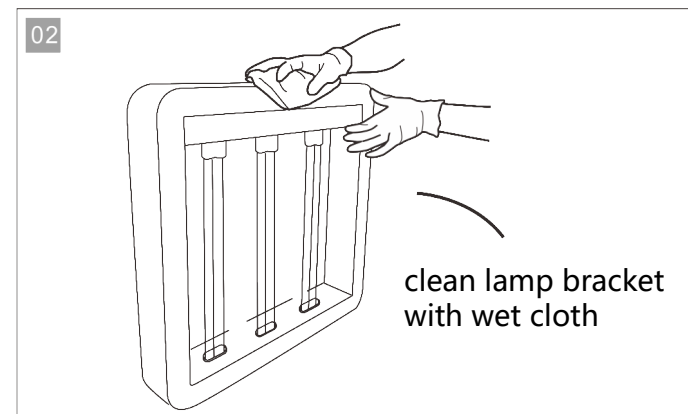
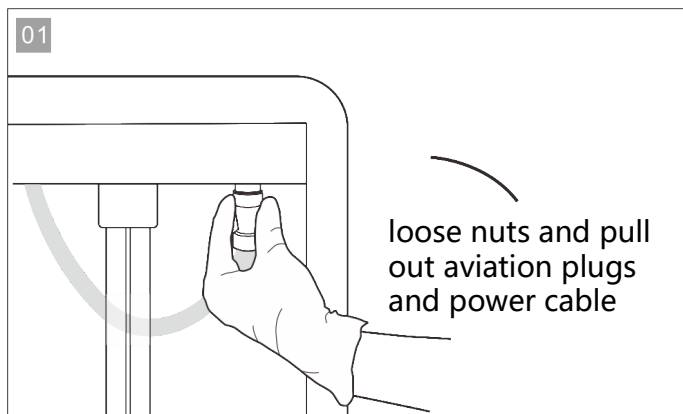

# 5. Maintenance

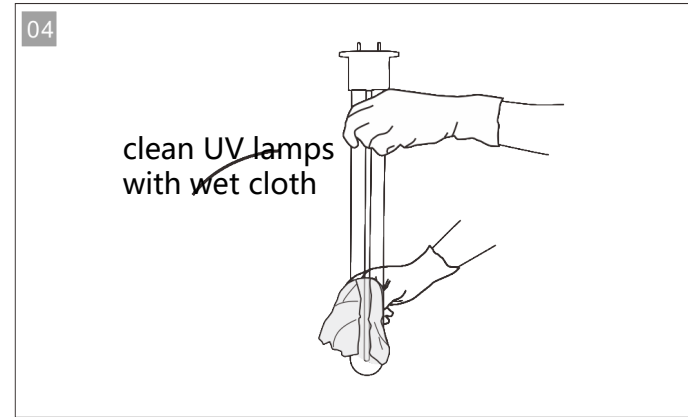
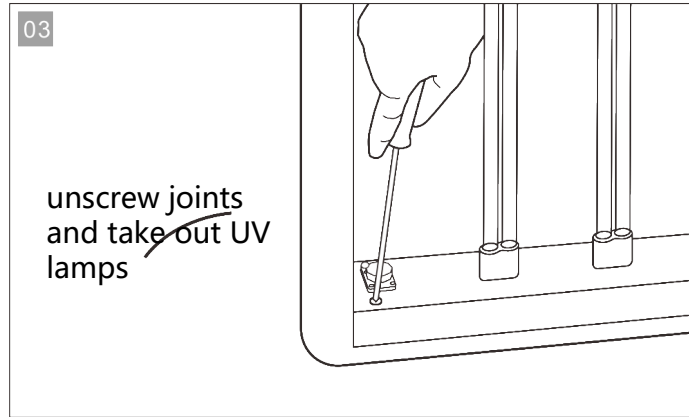

Requirements

Put UV lamps and other parts away to avoid possible damage caused by trampling or collision.  
Take good care of disassembled parts to avoid loss and affecting installation.



danger

Lamps are fragile. Please handle them with care to avoid damage on lamps or threatening personal safety.  
Do not use lamps with broken protective casing, which may cause short out.

# 5. Maintenance

Cracked feed-through insulator should be replaced in time.

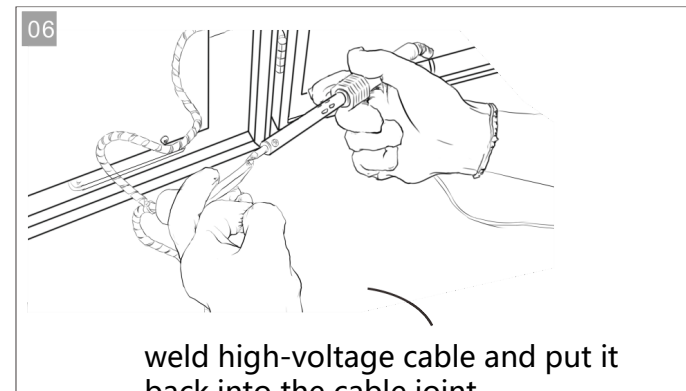
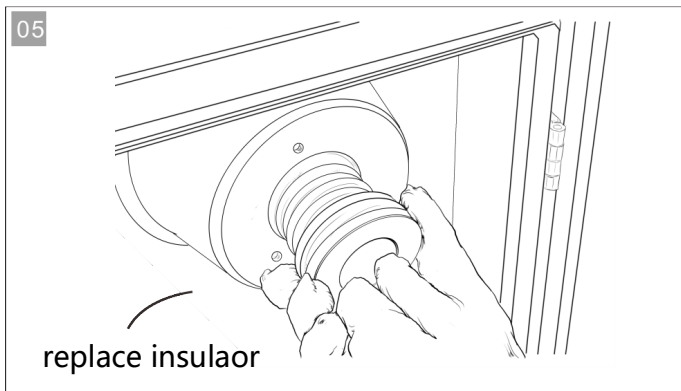
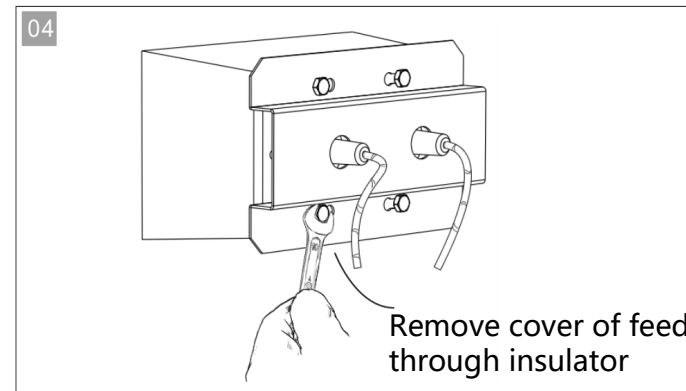
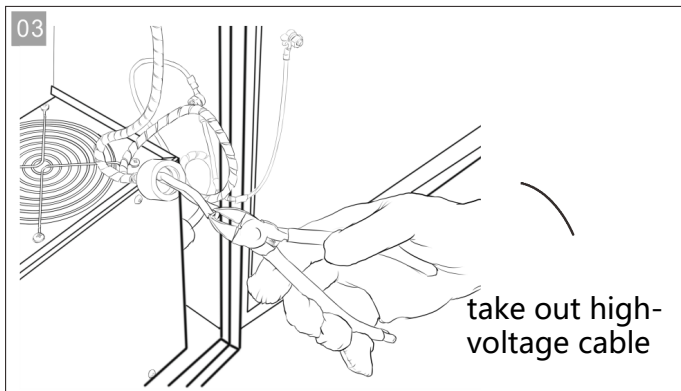
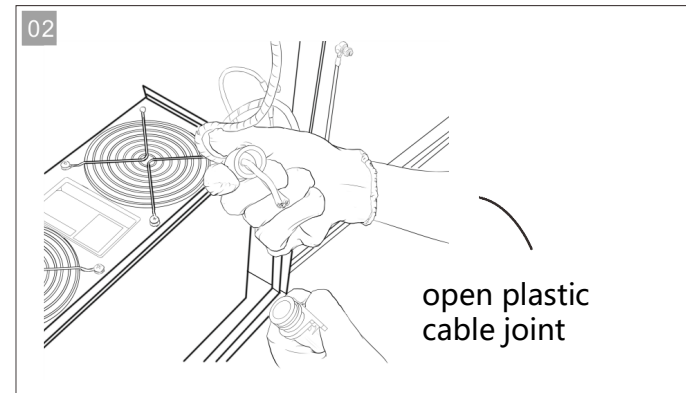
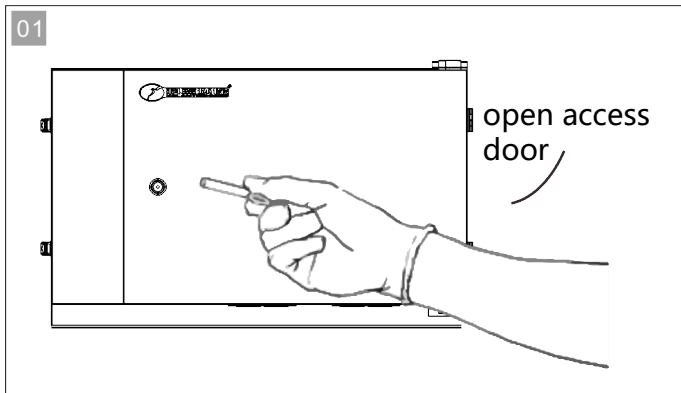

# 5.Maintenance

## Relace fuse

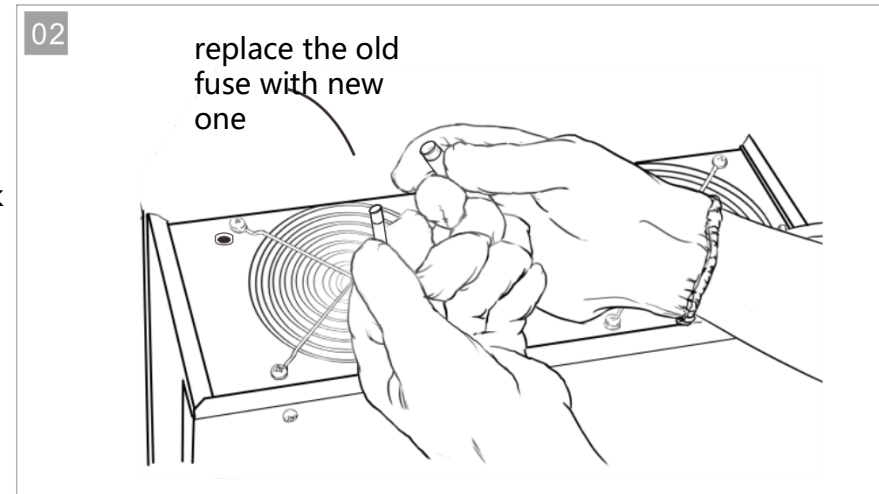
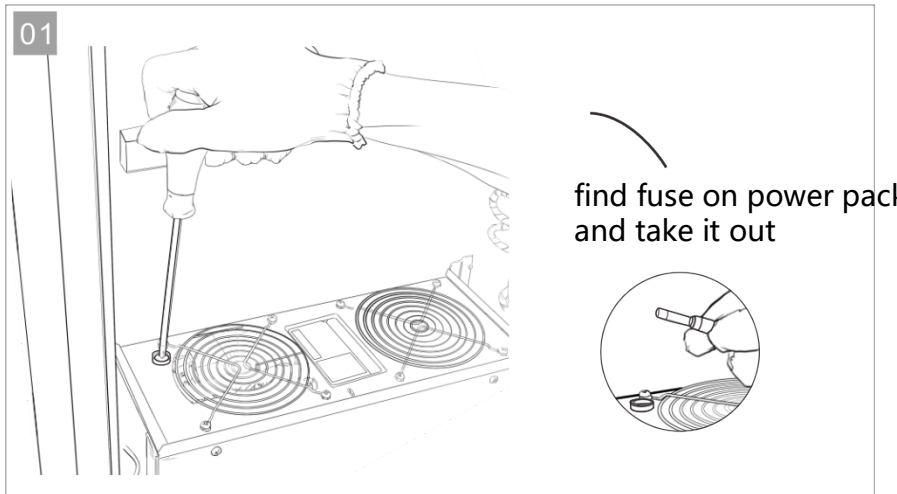

# 6. Trouble-Shooting

## 6.2 5.5 Malfunction Phenomenon and Solution

Phenomenon	Possible Causes	Solution
The power is supplied normally but the ESP/UV doesn't work	Fuse in the electrical box is burned down	Check and find out the causes and replace the broken fuse with a new one
	Cables get loosen	Check and tighten them
	UV lamp get broken	Check and replace it with new one
	Residual detergent or alkaline solution on the insulators	Rinse off the residual agents with clean water and wipe the insulators dry
	Electrical ballast get broken	Replace it with new one
	Exhaust oil mist temperature is over high	Cool it down

# 6. Trouble-Shooting

## 6.3 Fault code

Code	Possible Causes	Solutions
OFF	normal shutdown	
C01	Temperature Control Activation	Replace the cooling fan if it' s broken. Increase the cooling fan if there isn' t enough. Make sure the power pack enclosure is sufficiently ventilated.
C02	HV Output Open Circuit Protection: 1.No load in place. 2.Wrong installation of filter cells. The HV Feed-through connector is not in contact with the ionizer frame, resulting in no detection of load. 3. Wrong load type selection	1.Make sure the filter cells are installed in a way that the HV feed-through connector is in close contact with the ionizer frame. 2. Select the right or similar load type using the handheld debug box.
C03	HV Output Short Circuit Protection: 1. Ionizers in direct contact with collectors, causing short-circuiting. 2.Flashovers across the surface of the insulators 3. Filter Cell sprung connector is in direct contact with the grounded housing instead of being between two adjacent filter cells.	1. Remove the conductive debris, straighten the bent ionizers, or replace the broken ionizers. 2. Remove the conductive debris, straighten the bent ionizers, or replace the broken ionizers. 3. Make sure the HV Sprung connector is located between two adjacent filter cells
C04	Switch-on Current Surge Protection: Excessive current flows through the board upon switch-on.	Ensure a stable supply of AC power.
C05	Loss of Power: The input voltage from the AC Mains is too low because of low capacity of the isolation transformer, or because of too large electrical resistance through the AC Contactor	replace contactor or transformer
C06	Program Error Detection	replace PCB
C07	Software reset: PCB is interferred	replace PCB

# 6. Trouble-Shooting

## 6.3 Fault code

Code	Possible Causes	Solutions
C08	<p>Arcing Protection:</p> <ol style="list-style-type: none"> <li>1. The filter cell becomes heavily polluted, or ionizers deviate from the center of the collectors, causing arcing, which can be determined by continuously audible snapping sound.</li> <li>2. Exhaust air at excessive humidity</li> </ol>	<ol style="list-style-type: none"> <li>1. Clean the filter cells, or repair the bent ionizers.</li> <li>2. Make sure the product is used at a relative humidity not exceeding 90%, by using demisters, or by increasing exhaust air temperature.</li> </ol>
C09	<p>Door interlock switch Activation</p> <ol style="list-style-type: none"> <li>1. Access door is open;</li> <li>2. Door Interlock Switch failed</li> </ol>	<ol style="list-style-type: none"> <li>1. Close the Cell access door.</li> <li>2. Replace the Door Interlock Switch.</li> </ol>
C10	<p>No current &amp; no voltage Protection</p> <ol style="list-style-type: none"> <li>1. Poor or burnt wiring on the HV feed-through terminals between the HV transformer and the PCB.</li> <li>2. Damaged transformer</li> </ol>	<ol style="list-style-type: none"> <li>1. Secure the wiring, or replace the burnt wiring.</li> <li>2. Check for visible cracks on the transformer, and replace the cracked transformer.</li> </ol>
C11	<p>Over-current Protection: Excessive current flows through the board</p>	<p>Ensure a stable supply of AC power</p>
C12	<p>Over-voltage Protection: Excessive voltage is supplied to the board</p>	<p>Ensure a stable supply of AC power</p>
C13	<p>Current Cut-out Protection: Working current inside the filter cells cannot be detected</p>	<p>select the right or similar load type or replace PCB</p>
C14	<p>Flashover (a special form of arcing):</p> <ol style="list-style-type: none"> <li>1. Filter cell is dirty</li> <li>2. Insulators are cracked or heavily polluted</li> <li>3. Poor connection between the HV feed-through insulator and the ionizer frame.;</li> <li>4. Wrong load time selection</li> </ol>	<ol style="list-style-type: none"> <li>1. Clean the filter cell</li> <li>2. Clean the insulators and rinse them off thoroughly. Or replace cracked insulators;</li> <li>3. Make sure the HV feed-through connector is in close contact with the ionizer frame.</li> </ol>



GGM Gastro International GmbH  
Weinerpark 16  
D-48607 Ochtrup

[www.ggmgaastro.com](http://www.ggmgaastro.com)      [info@ggmgaastro.com](mailto:info@ggmgaastro.com)  
+49 2553 7220 0