

Index

10.03.2016

- 0. Introduction
 - 0.1. General information
 - 0.1.1. Preliminary operations
 - 0.1.2. Installation place
 - 0.1.3. Preparing for installation
 - 0.1.4. Electrical connection
 - 0.1.5. Hydraulic connection
 - 0.1.6. Exhaust connection
 - 0.1.7. Stacking ovens or condensation hood
 - 0.1.8. Technical specifications
 - 0.2. First use
 - 0.3. Board off
 - 0.4. Board on
 - 0.5. Home
 - 0.5.1. Keys
 - 0.5.2. Warning
- 1. 1st interface - Manual cooking and recipe creation
 - Time cooking
 - Core probe cooking
 - Delta T
 - Multitimer
 - 1.1. Setting the cooking chamber setpoint
 - 1.2. Setting the timer
 - 1.3. Setting the steam
 - 1.4. Setting the vent
 - 1.5. Setting the fan speed
 - 1.6. Setting the pre-heating
 - 1.7. Setting the core probe 1 and 2 setpoint
 - 1.8. Setting the delta T
 - 1.9. Setting the Multitimer
 - 1.10. Create recipe
 - 1.10.1. Create phase
 - 1.10.2. Delete phase
 - 1.10.3. Recipe saving
 - 1.10.3.1. Select saving folder
 - 1.10.3.2. Insert name
 - 1.10.3.3. Insert image
 - 1.10.3.4. Insert note
 - 1.10.3.5. Edit recipe
 - 1.10.3.6. Save recipe
 - 1.10.4. Start recipe
 - 1.10.4.1. Modifications during the start phase
 - 1.10.4.2. Stopping the cooking cycle
- 2. 2nd interface - Recipe book
 - 2.1. Bakery
 - 2.2. Pizza
 - 2.3. Pastry
 - 2.4. First dishes
 - 2.5. Seafood products
 - 2.6. Meat

- 2.7. Vegetables
- 2.8. Cooking programs
- 2.9. Favourite recipes
 - 2.9.1. Add recipe to favourites
- 2.10. Recipe search mode
- 2.11. Recipe start
- 2.12. Delete - Copy recipe
- 2.13. Edit recipe
- 3. 3rd interface - Settings
 - 3.1. USB
 - 3.1.1. USB and probe2 external connection
 - 3.1.2. Full update, apk or firmware
 - 3.1.3. Recipes export
 - 3.1.4. Recipes import
 - 3.2. CLOUD and WI-FI
 - 3.2.1. Connecting the oven to WI-FI
 - 3.2.2. Connecting the oven to the CLOUD
 - 3.3. Warnings and alarms
 - 3.3.1. List of alarms
 - 3.4. Date time and language
 - 3.4.1. Change keyboard and language
 - 3.4.2. Change date time and time zone
 - 3.5. Haccp
 - 3.6. Instruction manual - Consumption
 - 3.7. Trash can
 - 3.8. Service
- 4. 4th interface - Special cycles
 - 4.1. Core probe regeneration
 - 4.2. Time regeneration
 - 4.3. Delayed cooking
 - 4.3.1. Set date, time and choose recipe
 - 4.4. Holding
 - 4.4.1. Attach holding to a recipe
 - 4.5. MultilevelMix
 - 4.6. Cooling down
 - 4.7. Rinsing
 - 4.8. Washing
- 5. Pop up menu
 - 5.1. Calendar
 - 5.2. Light management
 - 5.3. Alarm clock
 - 5.4. Instruction booklet
 - 5.5. Information for use
- 6. Care and cleaning
 - 6.1. Chamber care and cleaning
 - 6.2. External and display care and cleaning
 - 6.3. In case of failure

0. Introduction

Dear client, thank you and congratulations on buying this appliance; we are confident that this is the beginning of a positive and long-lasting collaboration.

This manual has all the information necessary to correctly use, maintain and install this appliance. The objective of this manual is to enable the technician and user to take all measures and precautions necessary for the safe, efficient, long-term use of the appliance.

Keep this booklet in a safe place, for the entire life of the product for subsequent reference by authorised operators and specialist technicians. If documents are lost or damaged, replacements must be requested directly from the manufacturer or retailer.

The manufacturer is not held liable for any damage caused by people or things or for inappropriate use of the appliance, modifications or repairs carried out by unauthorised personnel or used with spare parts not recommended by the manufacturer and not intended for use with this model.

This appliance complies with the EEC directives in force.

Carefully read the following booklet as it provides installation, initial start-up, safety and use instructions for the device.

Carefully store it for future reference.

All installation, assembly, assistance and extraordinary maintenance must be carried out by qualified personnel and supplied with necessary professional requirements (authorisations by the manufacturer or retailer), in accordance with local laws in effect where installation takes place regarding product and workplace safety.

Incorrect installation, assistance, maintenance, use, cleaning, tampering with, or modifications can cause malfunctions, damage, and injuries.

That described above can affect the safety of the appliance and may render the warranty null and void.

The appliance was designed to cook food in closed environments and must be used solely for this purpose. Any other use must be avoided and is considered improper and dangerous.

The device is intended for professional use and should be used by qualified personnel.

People with reduced physical or mental abilities or unskilled and untrained people should not use the oven, unless they are supervised or have been instructed on how to operate the appliance by people in charge of their safety.

Do not leave the appliance unattended in the presence of children, and make sure they do not have access to the appliance or use it as a toy.

It is not recommended to place the appliance next to sources of heat.

Do not, for any reason, leave easily flammable material next to the appliance: it can cause a fire.

The food containers, accessories or other items can reach high temperatures during and after cooking. Be careful when handling in order to prevent burns. Only touch them when using heat-protection equipment such as thermal clothing. Danger of burns!

Be careful when opening the oven's door: danger of burns from high-temperature steam coming out. The oven is equipped with a safety system that automatically disables heating, fan and steam operation when the door is opened.

In the case of cooking using the core probe, use caution when removing the trays from the oven: make sure the probe is extracted from the food being cooked and doesn't get in the way.

Do not place flammable objects or alcohol-based foods in the oven: they cause combustions and fires that could give rise to explosives phenomena.

Do not put salt on food inside the cooking chamber of the oven. This can damage the cooking chamber. If it cannot be avoided, clean the appliance as soon as possible.

Use your fingers to adjust the control panel options. Using any other object can damage the appliance and thus render the warranty null and void.

The outer parts of the oven can exceed temperatures of 60°C. Therefore, to prevent the risk of burning, it is recommended not to touch the areas or parts marked with the symbol on the side.



Damage or breakage of glass components forming part of the door must be replaced immediately (contact Customer Care).

In the event of prolonged non-use (several days), it is recommended to disconnect the power and water supplies.

The manufacturer cannot be held liable for any damage caused to people or objects due to failure to comply with the aforesaid provisions, or deriving from tampering with even one single part of the appliance, and use of non-original spare parts.

This appliance complies with the EC directives in force.

0.1. General information

0.1.1. Preliminary operations

On receipt of the product, make sure it has not been damaged during transport and that the packaging has not been tampered with. In the case of damage or missing parts, inform the carrier and retailer/manufacturer immediately, indicating the **Code (Art.) and serial number (Ser No.)** and attach a photo.

Check that the installation area is kept clear so that doors, corridors and passageways are accessible.

ATTENTION: the appliance may fall over during transport leading to breakage and damage to things and people. Use suitable transport that can withstand the weight of the appliance. Do not drag or tilt the device for any reason. Lift it up straight from the ground and place horizontally.

0.1.2. Installation place

The appliance must be installed in an enclosed and well ventilated area (not outdoors).

The ambient temperature of the place of installation must be higher than +4°C.

Before positioning the appliance, check the overall dimensions and the exact position of the electrical, water and fumes exhaust connections.

We recommend putting the oven under an extractor hood or in such a way that hot fumes and odours exit the oven via adequate ventilation to the outside.

The oven must be placed on a flat surface so that it does not slip or turn over.

The installation area must be able to support the weight of the appliance filled to the maximum. We recommend using the manufacturer's tables in order to place the device in an proper way. See the Information Plate on the back of the oven for the gross weight.

Make sure that it is placed so that the door can be fully opened.

Position it so that the back of the oven is easily accessible for maintenance, connection to the mains sockets, and water.

The appliance is not meant to be fitted and a 5 cm space must be left around it.

It is **not recommended**, in order to ensure proper cooling of the components assembly, to position the oven near sources of heat, deep fryers or other sources of hot liquids; if this is not possible, observe the

safety distances which are: 50 cm to the side and above the equipment and 70 cm to the rear part of the oven.

Do not place the device near flammable materials or containers of flammable materials (such as walls, furniture, screens, gas canisters) as this can create a fire hazard. If this is not possible, cover the flammable parts with fireproof and heatproof material and check the fire hazard regulations.

0.1.3. Preparing for installation

Remove the outer packaging (wooden or cardboard box) and dispose of it in compliance with the laws in force in the country of installation.

- **REMOVING PROTECTIVE FILM ETC.**

Remove all the protective film from the external and internal walls. (refer to the photo on the side)

Remove all informative material from the inside, and take off all plastic packaging.

- **STAND ADJUSTMENT**

Do not use the appliance without feet.

The adjustable feet are already screwed to the underside of the oven. If they are not used, this prevents air from cooling the electric parts and outside of the oven which causes over-heating and damage to components.

The oven will function correctly if placed level on a flat surface by adjusting the feet accordingly and using a spirit level. Screw or unscrew them as necessary to adjust.

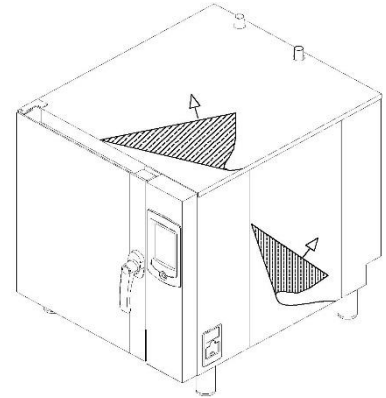

0.1.4. Electrical connection

ATTENTION: Mains connection must be carried out by a qualified and authorised technician according to national, international and local laws in the country where it is installed.

Before connecting the mains supply, ensure that the frequency (....V) and voltage (....Hz) meet the requirements indicated on the Information Plate situated at the back of the appliance.

The oven must be connected directly to the mains power supply and must have an easily accessible switch upstream from it. It must be installed to the system according to the national, international and local laws in the country where it is installed. This switch must have separate polarisation guaranteeing complete disconnection in accordance with the overvoltage III category. Correct earthing is obligatory and the earth wire must not be disconnected by the protection switch.

ATTENTION: if the appliance does not have supports with wheels that facilitate movement, it is recommended to execute the mains power supply connection first and then place it in its operating position, being careful that the power supply cable is not damaged during handling operations. This facilitates execution of the electrical connections in total safety. Place the cable in such a way that no point exceeds 50°C room temperature.

- **CABLE CONNECTION**

The oven must be connected to the electricity with a rubber cable such as H07RN-F.

ATTENTION: When connecting the power cable, arrange the different conductors so that the earth one (yellow-green) is three cm longer than the other wires.



Ovens are supplied with terminals, as in the image. To connect to the mains see the label in the manual and stuck to the lower part of the back of the appliance near the Information Plate .

Proceed as follows to connect the power supply wire to the terminal board:

- (A1) Loosen the tops of the cable gland and open the bottom part of the back of the appliance by loosening the screws.
- (A2) Feed the new cable through the cable gland.
- (A3) Connect the power supply cable voltage to the terminal strips following the connection diagram on the label on the back of the appliance. Only connect what is indicated inserting the copper bridge and the electricity cable together under the screws, in the tightening direction, so the cable and the bridge are tightly fixed by tightening the screw. The type of cable to be used (HO7RN-F) is indicated on the label for each connection and the cross-sections in mm².

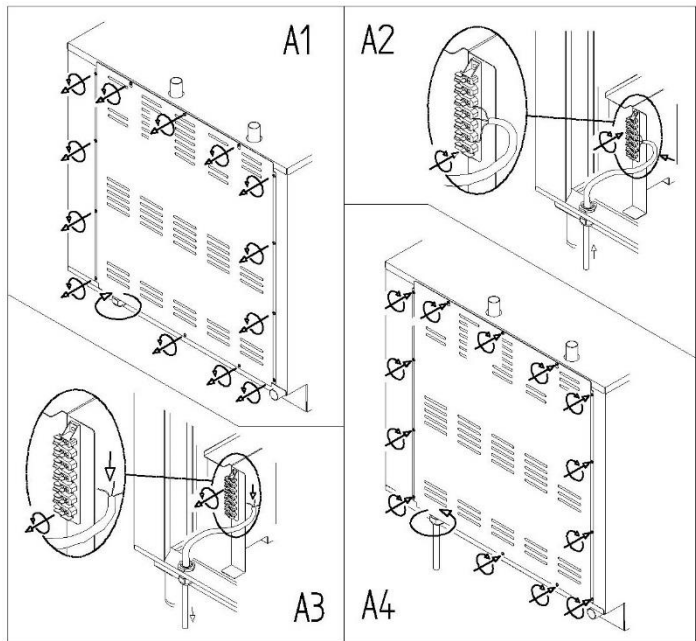

- (A4) Close the bottom part of the back of the appliance by tightening the screws and fit the cable by tightening the cable gland top.

An incorrect connection could lead to the terminal board overheating which could lead to a blowout and electric shock.

Check that all the connections are tight before connecting the oven to the mains.

- **PE = Yellow/Green** : “EARTH” power conductor.
- **N = Blue** : neutral conductor.
- **L1, L2, L3 = Brown, Grey, Black** : phase conductors

Check there is no static discharge between live and earth. Check the limit switch continuity between the external casing and the earth wire of the mains. We recommending using a multi-tester to carry out these operations

- **CABLE SUBSTITUTION**

This must be carried out by a qualified and authorised technician. The earth wire must always be yellow green.

ATTENTION: When connecting the power cable, arrange the different conductors so that the earth one (yellow-green) is three cm longer than the other wires.

Proceed as follows to connect the power supply wire to the terminal board:

- (A1) Loosen the tops of the cable gland and open the bottom part of the back of the appliance by loosening the screws.
- (A2) Loosen the terminal screws and feed the cable conductors through. Remove the old cable from the cable gland.
- (A3) Feed the new cable through the cable gland. Connect the new cable’s conductors to the terminal following the connection diagram on the label at the lower part of the back of the oven. Only connect what is indicated inserting the copper bridge and the electricity cable together under the screws, in the tightening direction, so the cable and the bridge are tightly fixed by tightening

the screw. The type of cable to be used (HO7RN-F) is indicated on the label for each connection and the cross-sections in mm².

- (A4) Close the bottom part of the back of the appliance by tightening the screws and fit the cable by tightening the cable gland top.

Check that all the connections are tight before connecting the oven to the mains.

ATTENTION: An incorrect connection could lead to the terminal board overheating which could lead to a blowout and electric shock.

Check there is no static discharge between live and earth. Check the limit switch continuity between the external casing and the earth wire of the mains. We recommend using a multi-tester to carry out these operations.

- **EQUIPOTENTIAL CONNECTION**

This connection must be done between different appliances with the terminal marked by the symbol: (refer to the photo on the side).

This terminal enables the connection of the Yellow/Green cable with a section between 2.5 and 10mm².

The appliance must be included in an equipotential system whose efficiency has been duly verified according to the provisions of the laws in force.



0.1.5. Hydraulic connection

- **WATER CONNECTION AND WASHING**

A mechanical filter must be placed between the mains water supply and the oven. The rear of the oven has a G3/4" inlet with pipe, for the water supply both for washing and steam. **ATTENTION:** Before connecting the appliance to the mains water supply, rinse with water to eliminate any residue. To guarantee proper operation of the cleaning system (washing and steam), the mains water supply pressure must be between 150kPa (1.5bar) and 200 kPa (2bar) and the temperature must not exceed 30°C. Lower water pressure values may prevent the cleaning system from working properly. If the inflow pressure value exceeds 200kPa (2bar), a pressure reducer will have to be installed, calibrated at 200kPa (2 bar).

- **WATER TREATMENT**

In order to ensure trouble-free operation of the device, the water should have a hardness of maximum 5°dH to prevent lime deposits. We recommend using a water softening device (reverse osmosis) to prevent lime and another minerals from forming deposits in the oven. We suggest the use of the manufacturer's recommended demineraliser appliance.

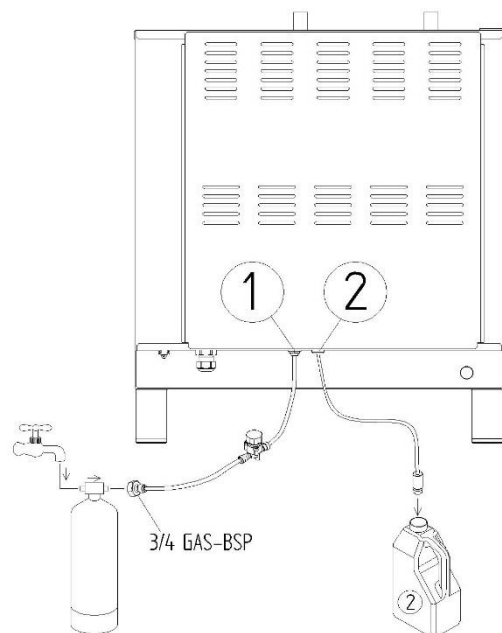

- **DETERGENT CONNECTION**

Insert the pick up pipe into the detergent tank.

1=Water inlet

2=CLEANING detergent inlet

0.1.6. Exhaust connection

- **DRAIN WATER**

Water discharged from the oven can reach high temperatures (90°C). The pipes used to drain the water must be able to withstand such temperatures.

The drain pipe is in the lower rear part of the oven and is to be connected with a rigid or flexible pipe and directed to an open or siphoned drain. Its diameter must not be less than that of the oven's discharge coupling. We recommend inserting a suitable siphon between the oven and the mains drain water system in order to prevent vapours from coming out of the oven and bad odours from entering from the mains drain water.

Avoid bends on the flexible pipes and rigid pipe elbows along the entire drain. The pipe must have a minimum 5% gradient along the section in order to ensure adequate outflow. The horizontal sections must not be longer than one metre.

The oven must have its own connection to the drains. If several pieces of equipment or appliances are connected to the same pipe, make sure its size enables normal outflow without any issues.

Local regulations and standards must be complied with.

- **FUME DISCHARGE**

Hot fumes and odours are emitted from the cooking chamber during cooking. This is located at the top part of the back of the oven. Do not place objects on the discharge so as not to hinder the outflow of the fumes and hence avoid causing damage. It is advisable to position the oven under a hood extractor or ensure adequate ventilation by directing hot fumes and odours outside through a pipe that must not be smaller than the oven drainage. Avoid bends and blockages.

0.1.7. Stacking ovens or condensation hood

Stacking several appliances requires the use of the special kit which keeps the correct distance between them.

0.1.8. Technical specifications

- **INFORMATION PLATE**

Your code/Name:

Art.: SG10TC

Model:

Ref.: SG10TC010101PL00NESSSI

Ser. N°: 0D0400256

TYPE:

IPX	kPa: 150-200
16,1 kW	380-415V 3N~ 380-415V 2N~ 220-240V 3~
	50-60 Hz

KG: 131

Ord: 16/03

RoHS
MADE IN ITALY

9000000057241

The diagram shows an information plate with several callout boxes pointing to specific fields:

- INFORMATION** points to the top-left field (IPX).
- POWER CONSUMPTION** points to the top-left field (16,1 kW).
- WEIGHT** points to the bottom-left field (KG: 131).
- POWER SUPPLY** points to the middle-right field (380-415V 3N~).
- FREQUENCY POWER SUPPLY** points to the top-right field (50-60 Hz).

Additional markings on the plate include: EAC, CE, a crossed-out trash can symbol, and a barcode with the number 9000000057241.

Code:	Model according to customer's classification.
Ref.:	Model according to manufacturer's internal classification.
Serial No.:	Identification number, different for each product
TYPE:	Certification code identification
Information:	IPX protection level against water sprays / kPa. Inflow water pressure / oven production year.
Power consumption:	Appliance nominal power in kW.
Power supply:	TERMINAL CONNECTION TYPE: device tension in V, number of phases and neutrals (3N = 3 phases and neutral).
Power supply frequency:	appliance frequency in Hz.
Weight:	Appliance weight in kg.

0.2. First use

Before putting the appliance into operation, you must carried out scrupulously all the checks necessary for establishing conformity of the systems and installation of this appliance to the regulations and the technical and safety indications in this manual.

Inside there must be no plastic bags, instruction booklets, plastic films and so on.

Make sure the tray support structure inside the cooking chamber is well secured to the walls. Otherwise, the trays containing food and hot liquids can fall and cause burns.

All packaging must be thoroughly removed, including the protective film applied to the walls of the oven.

The vents and the ventilation slots must be open and free from obstructions.

The pieces of the oven eventually dismantled for installing must be refitted.

We recommend connecting it to WI-FI and logging in to the CLOUD to install the latest update available. Alternatively visit the site and upload the update via USB.

• TESTING

The oven must be tested by carrying out a trial cooking session to check that the appliance is working properly and that there are no problems or malfunctions.

Turn on the oven and set a cooking cycle with temperature to 150° C, time to 10 min. and average humidity.

Check every item in the list below:

- The cooking chamber light is ON.
- The oven stops (heating, steam, motors/fans) when the door is opened and resumes operating when the door is closed again.
- On reaching the set temperature, the cooking temperature thermostat turns the heating elements off.
- The fans motors perform the automatic reversal of the direction of rotation; the reversal takes place every 2 minutes. Steam turns off briefly for 20 seconds when the machine is stopped.
- The cooking chamber fans spin in the same direction.
- Check that water is being discharged to the fan from the steam inlet duct in the oven chamber.



- **FIRST CLEANING OF THE OVEN'S COOKING CHAMBER**

Heat the empty oven to 200°C (392°F) for about 30 minutes in order to eliminate and odour from the thermal insulation.

Clean the walls of the cooking chamber with hot soapy water, then rinse; never use abrasive detergents or acids and use sponges that don't ruin the steel surfaces of the appliance.

Before cleaning, disconnect the device from the power supply and wait until it is fully cold or perform a washing cycle.

The cooking chamber must not have any solvent or detergent residue. They should be removed by rinsing thoroughly using a damp cloth and using appropriate eye, mouth and hand protection. Possible danger of corrosion.

0.3. Board off

When the unit is electrically powered and the board is "OFF", the screen will be shut off with red led on.

0.4. Board on

Press for 10 seconds the key with the red led to turn on Your oven. Wait for the appliance start-up, after which Your oven is ready for use. At first start up, it is recommended to perform all the operations described in section "First use" (paragraph 0.2). Pressing the external key with the red led for a couple of seconds sets the board to "OFF".

0.5. Home

In the home page there are four interfaces that give access to different paths:

- 1- "Manual cooking" menu
- 2- "Recipe book" menu
- 3- "Settings" menu
- 4- "Special cycles" menu

Press the icon  to display the oven system information.

Press the icon  to switch on or off the light inside the cooking chamber.





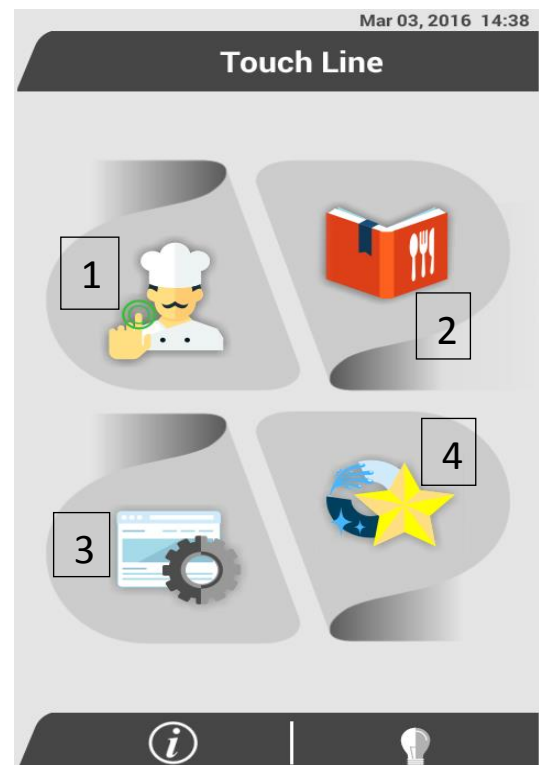

You can see information about date and time in the top right (see paragraph 3.4. Date time and language).

In the top left there is a status bar listing the oven's current processes (Warnings).











Press  in any screen to return to the home page.



0.5.1. Keys

	Manual cooking - Button to access manual cooking or create a recipe with several phases.
	Recipe book - Button to access the recipe book, where you can find every stored recipe.
	Settings - Button to access the oven's settings.
	Special cycles - Button to access the eight oven's special cycles.
	Light - Button to switch on and off the light inside the cooking chamber.
	Info - Button to display information about the oven.

0.5.2. Warnings

	Alarm - Alarm in progress Go to the alarms section  in the "Settings" menu to display the type of alarm active.
	Error – the device is not communicating correctly, wait 10 seconds and if the error persists, restart the device.
	Alarm clock - Alarm enabled on the device.
	CLOUD – device connected to the CLOUD.
	CLOUD – error in connecting to the CLOUD.
	Door status – shows when the oven's door is open.
	WI-FI - connected to WI-FI
	Delayed cooking - Cooking with delayed start enabled.
	USB – displayed when an USB flash drive is inserted in the device

1. 1st interface - Manual cooking and recipe creation

In this screen you can set manual cooking or create a recipe with up to 10 phases. You can find four cooking modes:

- **TIME COOKING** 

With this type of cooking you can set a specific length of time or an infinite time and you can adjust: temperature in the cooking chamber, humidity, fumes vent chimneys status, fan speed and preheating. Time cooking inhibits the adjustment of the core probes temperature.

- **CORE PROBE COOKING** 

With this mode you can set cooking using the precision of the two core probes. In addition to the core temperature, you can set: temperature in the cooking chamber, humidity, fumes vent chimneys status, fan speed and preheating. Core probe cooking inhibits the adjustment of time.

- **DELTA T** 





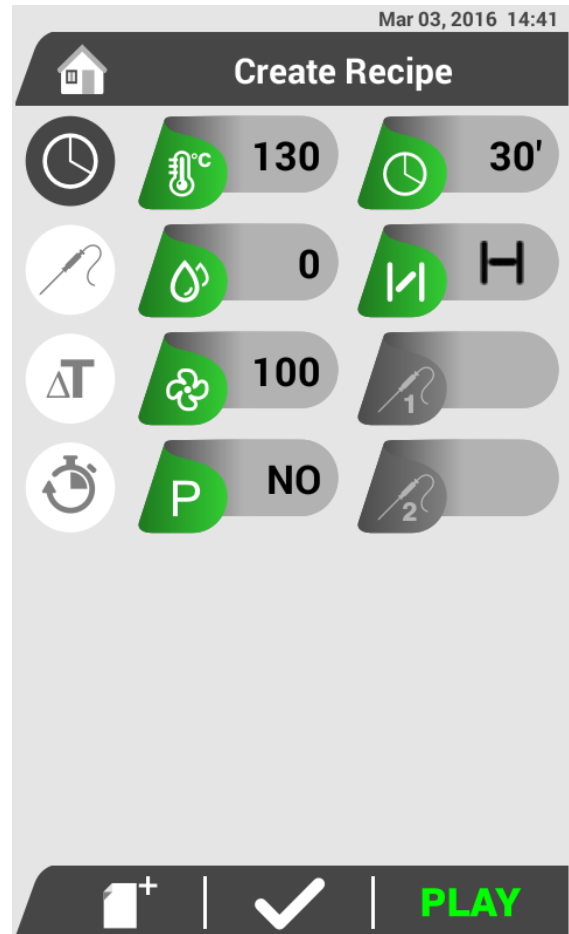

With this mode you can set cooking using the precision of one core probe. In addition to the core temperature, you can set: temperature in the cooking chamber, humidity, fumes vent chimneys status, fan speed and preheating. Delta T cooking inhibits the adjustment of time.

- **MULTITIMER** 

With this mode you can combine various cooking methods with a specific length of time; you can set: temperature in the cooking chamber, humidity, fumes vent chimneys status, fan speed and preheating. Time cooking inhibits the adjustment of the core probes temperature and the ability to create several phases.









1.1. Setting the cooking chamber setpoint

- Press , the display shows the chamber setpoint.
- Press ,  or scroll with  to change the value.
- Press  to confirm or  to exit without saving the setting.







Temperature can be set from 20 °C to 300°C (from 68°F to 572°F).

1.2. Setting the timer

- Press , the display shows the default value.
- Press ,  or scroll with  to change the value or press  to work with infinite time.
- Press  to confirm or  to exit without saving the setting.

The time can be set to infinite time or from 00:01 to 16:00 hh:mm. Once confirmed, the display shows the time in minutes. Countdown proceeds by the minute.

1.3. Setting the steam







- Press , the display shows the set steam value.
- Press ,  or scroll with  to change the value.
- Press  to confirm or  to exit without saving the setting.



You can choose between 11 values ranging from 0 to 100 (see side table). Each value represents the percentage of steam inside the chamber. You can set the steam setpoint this way:

Value	Steam Percentage
0	0%
10	10%
20	20%
30	30%
40	40%
50	50%
60	60%
70	70%
80	80%
90	90%
100	100%

- By setting the temperature values between 20°C to 130°C in the chamber you can use up to 100% steam.
- By setting the temperature values between 131°C to 230°C in the chamber you can use up to 100% steam.
- By setting the temperature values between 231°C to 300°C in the chamber you can use up to 100% steam.







1.4. Setting the vent

- Press , the display shows the chimney value.
- Press ,  or scroll with  to change the value.
- Press  to confirm or  to exit without saving the setting.

Closed	
Half open	
Open	

You can choose between 3 chimney positions (see side table). By default, the chimney is in the “closed” position.

1.5. Setting the fan speed

- Press , the display shows the value in percentage of the fans speed.
- Press ,  or scroll with  to change the value.
- Press  to confirm or  to exit without saving the setting.







You can choose from 10 values ranging from 10 to 100. Each value represents a percentage of the fans speed in respect to full speed.

Ventilation is active during the cooking cycle. Ventilation stops as soon as the door is opened and it is resumed once the door is closed.



1.6. Setting the pre-heating

To avoid the effects of heat loss when the oven door is opened to place food inside, preheat the oven to at least 30 °C higher than the desired cooking temperature.

The pre-heating function can be carried out every time you start a manual cycle or program.







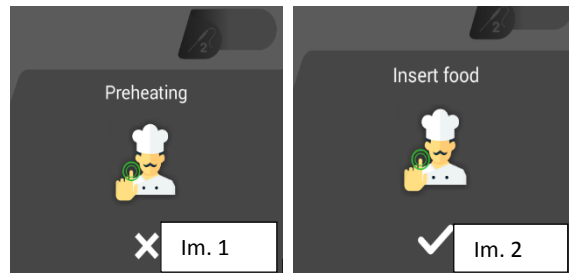

- Press , the display shows the value that you want to set preheating to.
- Press ,  or scroll with  to change the value.
- Press  to confirm or  to exit without saving the setting.
- You can also enable preheating in the screen “Phases list”.

TYPE OF LOAD	LOAD
Minimum load - 1\3	Preheating setpoint = adjustment setpoint + 10% Adjustment setpoint
Half load - 2\3	Preheating setpoint = adjustment setpoint + 20% Adjustment setpoint
Maximum load - 1\3	Preheating setpoint = adjustment setpoint + 40% Adjustment setpoint

you can choose between 3 preheating values, that is 1\3, 2\3 and 3\3 (see side table). If you decide not to carry out preheating, leave value (as set by default) to "0" and start cooking. The heating setpoint is limited to a maximum of 300°C. During preheating image 1 appears. On reaching the setpoint an intermittent sound starts and image 2 appears. The temperature is kept stable until the opening of the door or confirming the achievement by pressing the key , after which it will automatically start cooking. You can cancel the preheating by pressing  (Im. 1).















1.7. Setting the core probe 1 and 2 setpoint

- Press  to start setting a core probe cooking.
- Press  or , the display shows the default value.
- Press ,  or scroll with  to change the temperature you want to achieve inside the product.
- Press  to confirm or  to exit without saving the setting.

The core probe setpoint range is from 5°C to 100°C. There is a fixed core probe outside the cooking chamber and you can use a second one (optional) placed outside.

1.8. Setting the delta T

- Press  to start setting a delta T cooking.
- Press , the display shows the default temperature.
- Press ,  or scroll with  to change the temperature you want to achieve inside the product.
- Press  to confirm or  to exit without saving the setting.
- Press , the display shows the default temperature.
- Press ,  or scroll with  to change the delta you want to achieve in the chamber.
- Press  to confirm or  to exit without saving the setting.
 - The differential variation range (DELTA T) goes from 5°C to 90°C.

1.9. Setting the multitimer

To set the multitimer:

- Set the cooking values (chamber temperature, steam, fans speed, chimney).
- You can set up to ten timers.
- Press **PLAY** to start cooking.
- At the end of each timer a beep activates.
- During cooking, you can add multiple timers. This is a cooking based on infinite time.
- During cooking, you can add steam in the chamber by pressing .

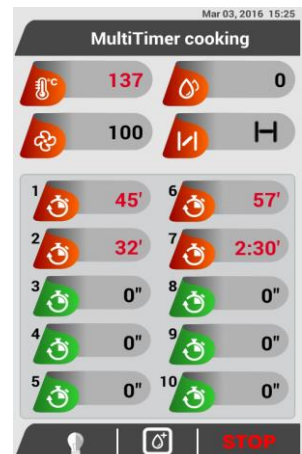



1.10. Create recipe

Up to 300 programmes can be memorised. The maximum number of phases is 10 plus the preheating phase. More than 150 recipes tested and adapted for the oven are already stored in the device. All recipes can be modified to the user's preference and each can be saved to a folder, with the opportunity to enter a name, an image of the product and a note to better explain the recipe.

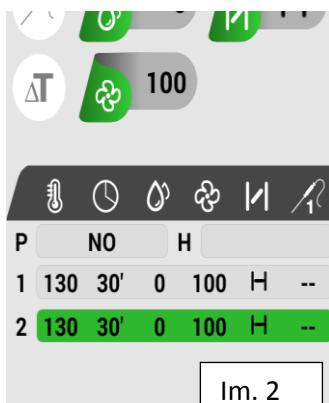
1.10.1. Create phase



- From the home enter in .
- Set all values as explained in the previous paragraphs (this is the first phase).
- Press  to add a phase (Im. 1).
- The screen displayed in image 2 appears.
- Now continue with creating other phases proceeding the same way.
- Once completed the recipe confirm with .
- You can change the previous phases by touching them on the bottom

list and changing the desired values (the green phase is always the selected one).

1.10.2. Deleting the phase

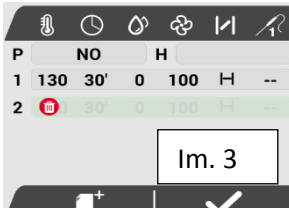

- To delete a phase during programming press and hold for 5 seconds over the phase in the summary.
- Press the trash can (Im. 3)

You can delete phases always starting from the last one created.

1.10.3. Recipe saving

- Once completed and confirmed the recipe with , a phases summary screen appears.
- On this screen there is an option to select the Save folder, enter a name, insert a picture, write a note, return to modify the recipe, save the recipe or start it without saving it.
- To start a recipe without saving press directly **PLAY**.

1.10.3.1. Select saving folder

1.10.3.2. If you want to save the recipe select the target folder.

- The first choice concerns the macro category that you want to associate (Im. 4)
- The second choice concerns the micro category that you want to associate (Im. 5).
- If you do not select any destination folder the recipe will be saved directly in the folder "my recipes"

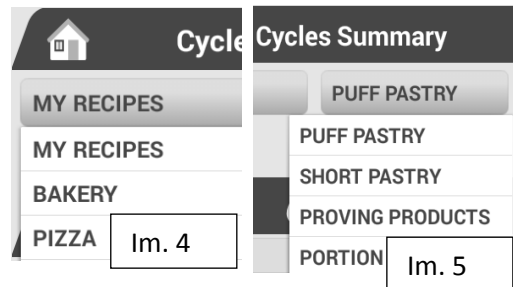



• Insert name

- To give a name to a recipe or change the current one press "my first recipe".
- The keyboard appears.
- Write or change the name using the keyboard.
- Confirm with the key "end".

1.10.3.3. Insert image

- To insert an image, after connecting the USB flash drive in the dedicated port, press  and select the image inside the drive.
- Crop it and save.

1.10.3.4. Insert note

- To add a note press .
- A window with a keyboard appears.
- Write the note that you decide to associate with this recipe and confirm with .

1.10.3.5. Edit recipe

- To return to modify the recipe press .
- Change values and phases as required.



1.10.3.6. Save recipe

- Once checked the phases summary press  to save the recipe.



1.10.4. Start recipe

- To start a recipe press **PLAY**.
- Make sure you saved it before starting it.

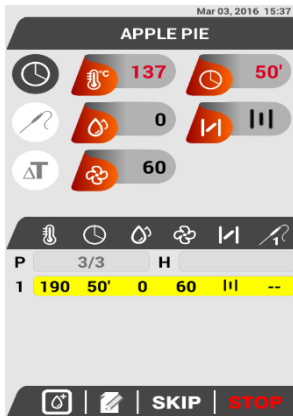
1.10.4.1. Modifications during the starting phase





During the starting phase you can:

- Change all values of the phase in progress or of the next phases. The values changed during the start phase are not saved, they are just temporary changes.
- Add steam in the chamber manually pressing .
- Read the note written for the recipe pressing .
- To move to the next phase even before the ongoing one has finished

press **SKIP**.

1.10.5. Stopping the cooking cycle

- To stop the cooking cycle before the set time press **STOP**.
- Once stopped or finished cooking you can return to the home page by pressing  or extend the last phase with the same values, with the option to increase the time by pressing .
- At the end of the cooking cycle the oven will beep for 5 seconds.
- At the end of each cooking the counter will show in hh:mm the overall duration of cooking.

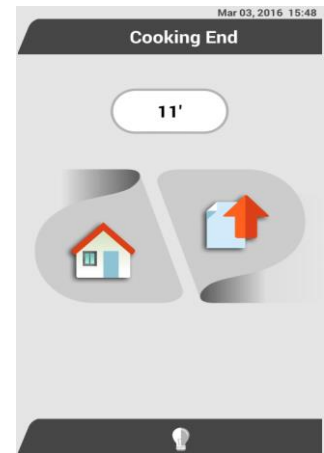

2. 2nd interface - Recipe book



3.

We designed a number of food processing systems to pursue the objective of precision and reliability of technical consistency. Our technology is the expression of a calibrated and measured technical, culinary, instrumental and methodological choice. In this screen you can choose one of the 150 recipes, both preset and saved by you. There are eight different categories which in turn contain other subcategories. The eight categories are: Bakery, Pizza, Pastry, First dishes, Seafood products, Meat, Vegetables and Cooking programs. Furthermore, in this screen you can enter the Favourite recipes and Search mode.

3.1. Bakery



In this category you can find all the products related to the bakery. We decided to split the main categories depending on the size of the product, grouping them into four micro categories:

- Large bread
- Medium bread
- Bread portion
- Gluten free

3.2. Pizza



In this category you can find products such as pizza and focaccia bread. We decided to split the main categories depending on the type of the product, grouping them into four micro categories:

- Pizza
- Focaccia bread
- Single portion
- Gluten free

3.3. Pastry



In this category you can find all the products related to the pastry. We decided to split the main categories depending on the size of the product, grouping them into five micro categories:

- Puff pastry
- Shortcrust pastry
- Leavened products
- Single portion
- Gluten free

3.4. First dishes



In this category you can find all the preparations related to first dishes. We decided to split the main categories depending on the preparation type, grouping them into two micro categories:

- Steam
- Au gratin



3.5. Seafood products

In this category you can find all the preparations related to seafood products. We decided to split the main categories depending on the size of the product, grouping them into four micro categories:

- Whole fishes
- Fish portion
- Shellfish
- Molluscs



3.6. Meat

In this category you can find all the preparations related to meat. We decided to split the main categories depending on the origin, grouping them into six micro categories:

- Chicken
- Turkey
- Pork
- Bovine
- Derived
- Birds - Game



3.7. Vegetables

In this category you can find all the preparations related to vegetables. We decided to split the main categories depending on the type of cooking, grouping them into four micro categories:

- Steam
- Au gratin
- Semifinished products
- Oven cooked



3.8. Cooking programs

Within these categories there is a folder where all the new user-created recipes (Personal key) are saved. There is also a folder where the daily menu is saved; thanks to MultilevelMix it combines several recipes to prepare at once (MultilevelMix key).

3.9. Favourite recipes



In this section you can find all the recipes that you believe are most important and that you use most frequently. You can select up to 20 favourite recipes.

3.9.1. Add recipe to favourites

To add a recipe to the favourites folder you simply have to click the star next to the recipe name (Im. 1). When a recipe belongs to the favourites category the star will be yellow, otherwise the star will be grey.



3.10. Recipe search mode

Once entered the recipe book or on each following page, press  to search for a recipe. Enter the name with the keyboard starting with the first letters.

3.11. Start recipe



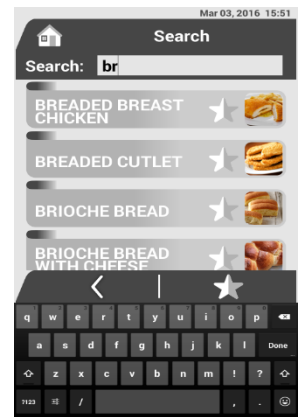

To start cooking:

- Press on the recipe name
- The page with the summary appears
- Read and press **PLAY**.



3.12. Delete - Copy recipe

3.13. To delete or copy a recipe:

- Press on a recipe for 5 seconds.
- Press  to copy the recipe.
- A new recipe with a different name opens; you can edit the original recipe without overwriting it.
- Press  to delete the recipe and confirm with  or cancel with .



3.14. Edit recipe

To edit a recipe:

- Select a recipe and press on the name.
- Once the summary page appears press .
- Modify the recipe as required and save, overwriting it.

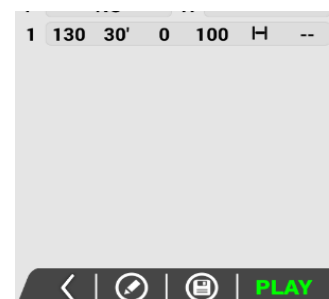

4. 3rd Interface - Settings

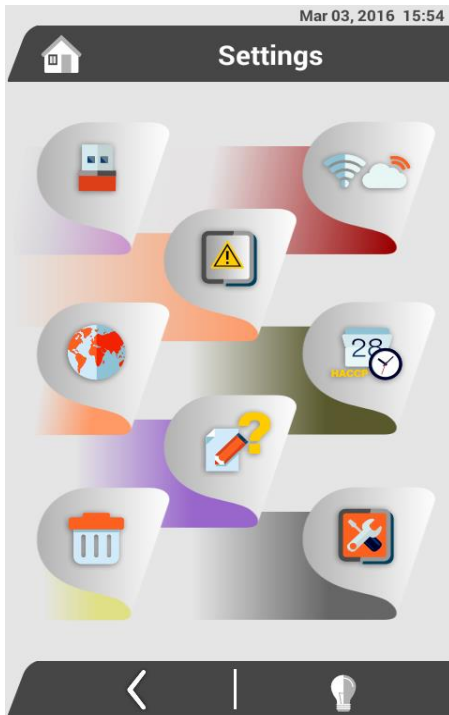

In this screen you can access all the oven's settings.

You can download and upload recipes via USB and then share them, upload updates, connect to WI-FI and to the CLOUD, check whether there are active alarms and know what kind of problem there is, set time, date and time zone.

You can set the preferred language by selecting it among the 10 most widely spoken languages and adapt your keyboard to suit your needs.

Download the haccp plan of your cooking via USB to keep under control all food transformation processes.

You can always reach the instruction manual for an easy and fast consultation when in doubt; you can restore or delete the recipes previously removed from the folders of the recipe book.

4.1. Usb



In this folder you can upload or download updates and import or export recipes directly via USB.

4.1.1. USB and probe2 external connection

To connect the USB and the probe2 open the door outside the oven (right side); you can connect the USB at the top and the probe2 at the bottom.

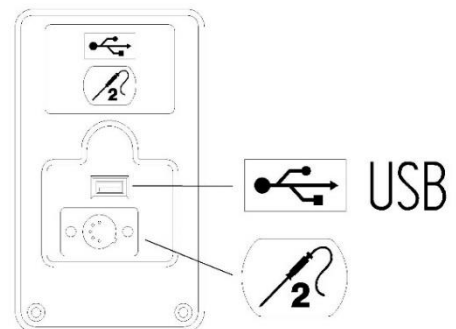

4.1.2. Full update, apk or firmware

Depending on the type of update, proceed as follows:

- Insert the USB flash drive containing the update file in the dedicated slot.
- Depending on the type of update, proceed by clicking on the entry.
- Press install and follow instructions.

4.1.3. Recipes export

4.1.4. To export recipes:

- Insert the USB flash drive in the dedicated slot.
- Click on "export recipes".
- Select the recipes to export.
- Press .

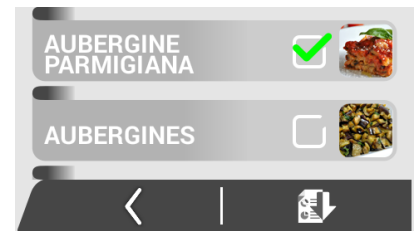

4.1.5. Recipes import

To import recipes:

- Insert the USB flash drive in the dedicated slot.
- Click on "import recipes".
- Select the recipes file to import.
- Press "ok".

4.2. CLOUD and WI-FI



In this folder you can connect the device to WI-FI and to the CLOUD, to allow the oven sending data to the server and downloading the updates. Make sure the access point is configured with one of the following security protocols, that the WI-FI can manage:

- WEP 64/128
- WPA TKIP
- WPA2 AES
- WPA2 PSK
- WPA2 Mixed Mode
- EAP TLS
- PEAPv0

4.2.1. Connecting the oven to WI-FI

Connecting the oven to WI-FI

- Click on the entry WI-FI.
- Turn ON the device.
- Wait for it to find the available network.
- Press on the chosen network and enter the password if required.
- Confirm and press "next".
- Wait a few seconds for the device to connect.

- **Connecting the oven to the CLOUD**

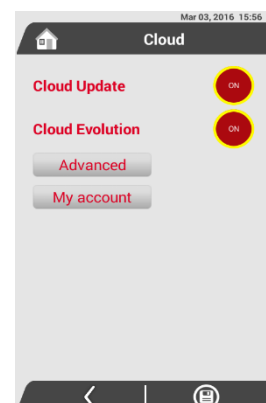

To connect the oven to the CLOUD:

- Click on the entry CLOUD.
- Turn "CLOUD Update" to "ON" to allow the oven downloading the updates from the CLOUD automatically.
- Turn "CLOUD Evolution" to "ON" to let the device connect to the CLOUD and send the real time status of the oven in order to remotely control it or save data such as haccp in real time.



- Press  to save changes.
- The technician can configure the oven with the “Advanced” button.
- Press “My account” to display account and password used to access the CLOUD service.

4.3. Warnings and alarms

In this folder you can find all the history of the alarms that triggered, useful for any maintenance work. You can save the alarms list via USB by pressing  or delete every alarm by pressing .

4.3.1. List of alarms

ALARM	SOLUTIONS
Serial communication error	Check the cables connection between the display board and the power board
FW incompatibility	Contact customer service
Chamber probe error	<ol style="list-style-type: none"> 1- Check that the chamber probe is properly connected 2- Replace chamber probe
Core probe error	<ol style="list-style-type: none"> 1- Check that the core probe is properly connected 2- Replace core probe
Optional core probe error	<ol style="list-style-type: none"> 1- Check that the core probe is properly connected 2- Check that the connector is properly connected to the power board 3- Replace core probe
Probe board error	Contact customer service
Maximum temperature in the chamber	Contact customer service - The maximum temperature has exceeded the set point value abnormally.
Fans thermal protection	Check proper operation of the fan motors
Safety thermostat protection	Contact customer service
High energy consumption	Contact customer service - Check the appliance's input voltage
Board high temperature	<ol style="list-style-type: none"> 1- Make sure that the room is well ventilated 2- Verify that the cooling motor is properly working

4.4. Date time and language

In this folder you can change everything about time, data, time zone, device language and keyboard layout.

4.4.1. Change keyboard and language

To change the language:

- Click on the entry “language”.
- Choose the desired language.
- The keyboard layout changes automatically according to the chosen language.
- Press  to save all data.

4.4.2. Change date, time and time zone

To change date, time and time zone:

- Click on “date and time”.
- Choose the desired time zone.
- Set the date.
- Set the time.

- Save by pressing .

4.5. Haccp



To download Haccp (Hazard Analysis and Critical Control Points):

- Insert the USB flash drive in the dedicated slot.
- Choose the start date for the Haccp period that you want to download.
- Choose the end date for the Haccp period that you want to download.
- Press  to save on the USB flash drive.

If you are connected to the CLOUD, the device stores the data for a year. Past the first year of use, the oven will begin to overwrite the data, deleting the previous ones, but keeping available a past history of 365 days.

4.6. Instruction manual - Consumption



Press “Manual” to read the instruction manual. You can zoom in on the page by tapping the area to be enlarged with two fingers and then moving them apart (pinch to zoom).

You can download it via USB by pressing .

To read the consumption list, press “Power consumption”. The list is composed of the following values:



- ON time.
- Cooking time.
- Heating elements consumption.
- Motors consumption.
- Lights consumption.
- Steam water consumption.
- Water consumption.
- Detergent consumption.

It's important to know the consumption to have a clear idea of the exact cost of each preparation and of all types of cooking.

4.7. Trash can



In this you can find all the recipes previously deleted from the recipe book. You can restore the recipe or delete it permanently:

- Select the recipes that you want to delete permanently.
- Press  to restore the recipes.
- Press  to delete the recipes permanently.

4.8. Service



This folder is password-protected; it is used by the technician to configure the oven and for any maintenance.

Only authorised personnel can access Service.

5.4th Interface - Special cycles

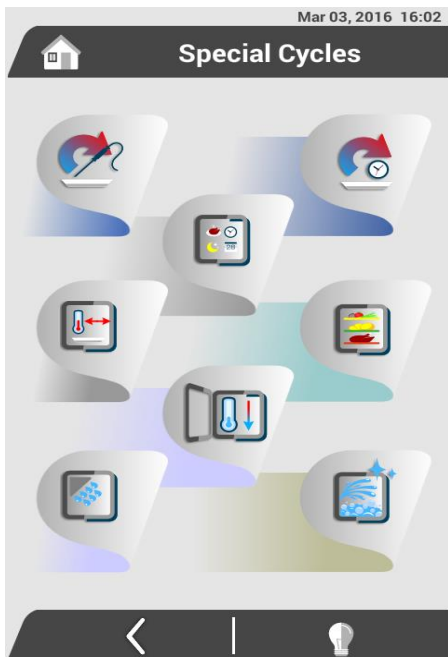

In this screen you can access all the oven's special cycles.

We designed eight different special cycles that make this an unique kind of oven. Some special cycles were divided into different programs with different values to better adapt to any kind of preparation.

In all special cycles with multiple programs you may know the details of the various programs by clicking on .

In addition to two regeneration programs you can find a cooking program with delayed start, holding, MultilevelMix, fast chamber cooling, rinsing and washing.

5.1. Core probe regeneration



Core probe regeneration is used for all those delicate products that require the precision of the core probe to reach the right serving temperature. Inside this folder there are six different regeneration programs all with different values for every type of food. Knowing all the values of each program, you can easily associate each preparation with the right regeneration.

5.2. Time regeneration







Time regeneration is used for all those products that don't require the core probe or when the core probe can't be used. Inside this folder there are six different regeneration programs all with different values for every type of food. Knowing all the values of each program, you can easily associate each preparation with the right regeneration.

5.3. Delayed cooking

Thanks to this application you can select a recipe and decide to get it started later. Useful for low temperature cooking with very long times. It allows you setting the start at any time of day; on returning, you will find the product ready. In addition to cooking you can also start a washing cycle.

5.3.1. Set date, time and choose recipe

To start a delayed cooking:

- Click on “Delayed cooking ” or “Washing ”.
- Choose the desired starting date and time.
- Press **PLAY**.
- Select the previously saved recipe or a washing cycle.
- Confirm with  or cancel with .
- The program is automatically saved after confirmation.
- The icon  appears.
- To cancel the start enter in “delayed cooking” and press .

5.4. Holding







Thanks to this application you can choose five holding programmes that will keep the product warm and ready for serving without affecting the properties of food and ensuring the same quality as freshly cooked food.

5.4.1. Attach holding to a recipe

You can start a holding program directly from the interface "special cycles"; else, before starting a recipe, there is the option of attaching the holding program. You can also attach it to an in progress cooking.

To associate holding to a recipe:

- Enter in “phases summary”.
- Press “H”.
- Choose one of the five holding programs.
- Once completed the recipe, the selected holding starts automatically.
- To delete it, see “1.10.2. Deleting a phase”.
- If the last phase is with infinite time, holding doesn't start.

     						
P	3/3	H				
1	210	10'	0	100		--
2	180	15'	0	60	H	--

- You can save a recipe with the set program. To save see “1.8.3. Recipe saving”.
- You can add holding even if cooking has already started.

5.5. **MultilevelMix**



Thanks to this application you can associate multiple compatible recipes to be cooked together, to create the menu of the day. You can save the pairing to always have and share the menu of the day.

To pair several recipes:

- Enter in MultilevelMix.
- Choose a free space, choose a recipe.
- The first recipe will serve as a basis for cooking and for the selection of the next ones.
- Proceed with the selection of other recipes that are compatible with the first one chosen. (The oven automatically locates them)
- To delete a recipe, press for five seconds on the recipe.



- Press  .

5.6. **Cooling down**



This program is used to automatically reduce the temperature of the oven in no time.

To start cooling down:

- Press  .
- Choose the temperature that you want to achieve in the chamber.
- Confirm by pressing  .
- Open the door.

During the ON phase you can change the temperature to be achieved. The oven will automatically start the fans and will begin to lower the temperature in the cooking chamber. On completion of the operation, the oven will beep.

5.7. **Rinsing**



Thanks to this application you can start one of the three rinsing programs. It is used to quickly rinse the cooking chamber to switch from one cooking to the other, avoiding that residues of the previous preparation end up on the new product that you are putting in the oven. Depending on the chosen program (soft, medium, hard) the duration changes; it is shown in the info. Only water will be introduced into the chamber while the program is active.

5.8. **Washing**



Washing system operation is fully automatic: simply select the desired program, choosing from soft, medium or hard. In addition to the three washing programs there is the program "detergent refill" that must be run in the following cases:

- At the first start up after installation.
- Every time the detergent in the container runs out.
- After a long period of non-use.

ATTENTION:

- Before starting any of the four programs ensure that there is no product in the oven.
- Before starting a cleaning cycle, make sure that the water drain on the bottom of the cooking chamber is clear, to prevent flooding the chamber.
- Never open the cooking chamber when a cleaning cycle is in progress. Chemical substances and hot fumes may escape causing burns and corrosion.
- At the end of every cleaning cycle, make sure that no detergent residue is left in the cooking chamber. Remove any residue from the cooking chamber and rinse manually.
- We recommend using the detergent approved by the manufacturer.
- The use of a non-approved detergent may damage the cleaning system and may affect the integrity of the cooking chamber, rendering the warranty null and void.

For a perfect operation of the cleaning system the oven ensures that prior to starting a cleaning program the cooking chamber temperature is below 100°C. In case of higher temperatures the cooling program will start automatically; once reached the appropriate temperature, washing will automatically start.

6. Pop up menu

To enter the pop up menu, drag your finger from the top of the screen to the bottom of the screen: the drop-down list appears. You can access this menu from any screen. Thanks to quick access you can have the calendar always available, turn on or turn off the light, set an alarm, read the instruction manual or any info regarding the oven.

6.1. Calendar

Thanks to the calendar you can always keep the week under control to better manage the daily and monthly work.

6.2. Light management

Through this pop-up menu you can have light management under control at any time and in any available screen.



6.3. Alarm clock

With this application you can set an alarm not to forget some important appointment.

To activate an alarm:

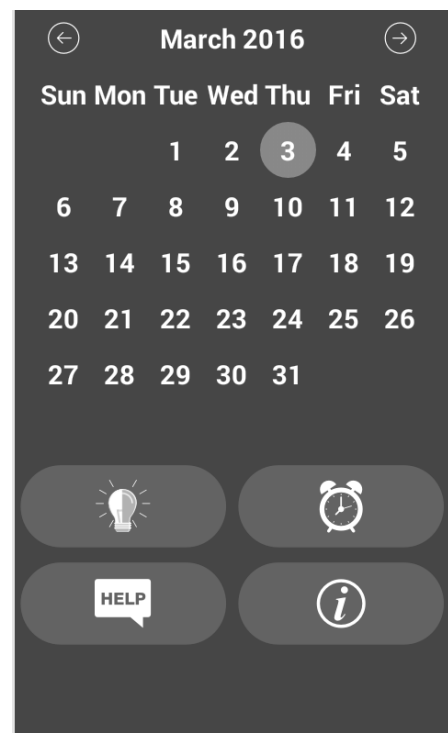
- Press .
- Choose the time of activation of the alarm.



- Press  to cancel.
- Press  to confirm.
- Press  to delete the alarm.

Activating the alarm will activate the buzzer and will continue ringing until you press .

6.4. *Instruction booklet*

In case of any doubt you have the opportunity to quickly consult the instruction manual to continue working without problems.

6.5. *Information for use*

With all the Info under control you can keep tabs on all statuses of the relays. You can also view all the info regarding the oven such as temperatures inside the chamber or those of the probes.

7. *Care and cleaning*

The user is solely responsible for ordinary maintenance. Customer Service must be contacted for extraordinary maintenance, which requires a specialist authorised technician.

Before cleaning, disconnect the device from the power supply and wait until it is fully cold or perform a washing cycle.

ATTENTION: never clean the device with water jets or pressurised steam.

7.1. *Chamber care and cleaning*

At the end of a day's work, it is necessary to clean the equipment, both for hygiene reasons and to avoid operating failures. The oven must never be cleaned with direct or high pressure water jets. Similarly, for cleaning the appliance you should not use iron scouring pads, brushes or common steel scrapers; you can optionally use stainless steel wool, rubbing it in the direction of the satin finish of the sheets. Use plastic bristles or a sponge soaked in vinegar and warm water in the case of dried residue. Use the washing programs already on the oven, if available.

For **manual cleaning** follow the procedure below:

- Wait for the cooking chamber to cool down.
- Remove the side grids that hold the baking trays.
- Remove any manually removable residues and put the extractable parts in a dishwasher.
- Turn on the appliance and set the temperature to 80°C.
- Leave it on for 10 minutes on 100% steam.
- Turn the appliance off and let it cool down. It is strictly forbidden to wash the cooking chamber in cooking temperatures higher than 70°C. Danger of scalding.
- Spray the detergent on the entire inner surface of the oven and wait 10 minutes.
- Rinse, being careful to ensure that no detergent residue remains.

Daily cleaning of the oven cooking chamber washer must be carried out with a non-abrasive detergent to guarantee its proper functioning.

Any fats and food residues in the cooking chamber could catch fire when using the oven, therefore, it is advisable to remove them promptly.

Only use products recommended by the manufacturer of the appliance

7.2. External and display care and cleaning

To clean the outside of the oven using a damp cloth with warm water and products suitable for cleaning steel. Do not use acidic products or ammonia.

ATTENTION: never clean the device with water jets or pressurised steam.

- **CLEANING THE DOOR AND THE DOOR INTERNAL GLASS**

To clean the door internal glass wait until the oven has completely cooled down. You simply have to turn the blocks which lock the inner glass. Then rotate the glass. In this position, with the glass still hinged, you can thoroughly clean the entire door.

- **WATER INLET FILTER CLEANING**

To clean the water inlet filter, unscrew the cap on top of the filter and remove it (in this operation remove the inner filter also). Rinse thoroughly with plenty of water. Reassemble the filter.

- **DISPLAY CLEANING AND CARE**

Clean the display daily. Clean it with a piece of paper and with a special spray for glass. Avoid contact with sharp materials that can ruin the screen. Avoid cleaning it with water jets or steam under pressure.

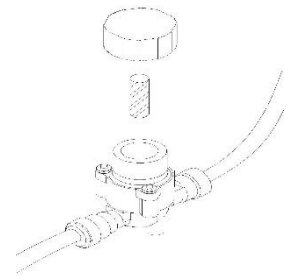

7.3. In case of failure

It is advisable to have the appliance subjected to periodical checks (at least once per year) by a specialist, authorised technician.

Any maintenance, installation or repair work must be carried out by qualified, authorised personnel by contacting the Customer Service. Before carrying out any operation the appliance must be disconnected from the mains power supply, turn off the water mains taps and wait for it to cool down.

Before moving the appliance from its position, check that the electricity and water connections (electric cables, water pipe and drainage) have been properly disconnected.

If the appliance is on wheels check that the electric cables, pipes or anything else are not damaged while moving it. Ensure the brake is on. Avoid placing the oven near heat sources (such as fryers, etc.).

After carrying out the task and returning the appliance to its initial position, check that the electric and water supplies are connected correctly.

If the appliance breaks, disconnect it from the mains power supply and turn off the water.

Before contacting Customer Service, check the chart below.

FAULT	CAUSE	SOLUTION
The oven in PLAY doesn't start	Door open	Make sure the door is closed.
	The micro-switch does not signal that the door is closed	Contact a specialist technician for repairs (Customer Service).
Oven light off	Loose lamp	Insert the lamp correctly into the lamp holder.
	Blown lamp	Replace the lamp (refer to ordinary maintenance).
The oven does not cook uniformly	The fans no longer execute inversion	Contact a specialist technician for repairs (Customer Service).
	One of the fans has stopped	Contact a specialist technician for repairs (Customer Service).
	One of the heating elements is broken	Contact a specialist technician for repairs (Customer Service).
	Door washer out of place	Put the oven door washer properly in its seat.
The oven is completely off	No power supply	Restore the power supply.
	Incorrect connection to the mains power supply	Check connection to the mains power supply.
	Safety thermostat triggered	Contact a specialist technician for repairs (Customer Service).
No water is input into the steam pipes	Water inlet closed	Open water inlet.
	Incorrect connection to the mains water supply	Check connection to the mains water supply.
	Water inlet filters obstructed by dirt.	Clean the filters
Water leaks out from the washer when the door is closed.	Dirty washer	Clean the washer with a damp cloth
	Damaged washer	Contact a specialist technician for repairs (Customer Service).
	Door closing mechanism problem	Contact a specialist technician for repairs (Customer Service).
The fan stops during operation	Motor safety thermostat triggered	Switch the oven off and wait for the motor's thermal protection to restore automatically. If the problems persists, contact a specialist technician for repairs (Customer Service). Verify compliance with the safety distances of the oven.
	Motor condenser breakage	Contact a specialist technician for repairs (Customer Service).

If the problem persists, we advise you to contact the retailer or manufacturer asking for Customer Service, specifying the problem and supplying the **code (Art.) and appliance Ser No.** of your device. This information is provided on the Information Plate on the back of the machine.

- **SPARE PARTS**

Use only authorised parts for product repair. All interventions must be carried out by authorised and specialist technical personnel. Contact Customer Service to request spare parts.

- **REPLACING BULBS**

ATTENTION: Strictly adhere to the following procedure in order to avoid electrocution and damage to people:

- Disconnect the oven from the electrical supply and leave it to cool.
- Remove the side grids that hold the baking trays.
- Unscrew the glass cover "A" while paying attention not to damage washer "C". Replace the lamp "B" with one having the same characteristics.
- Reassemble the whole, screw on glass cover "A" while observing washer "C".
- Put the side grids back on ensuring they are well fitted.

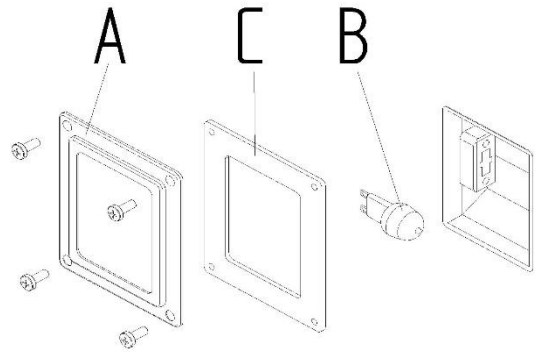

Should the glass lid break or get damaged, do not use the oven until the lid is replaced (Contact Customer Service).

Document for installation

Reseller:	Technician: Serial No.: Installation date:
-----------	--

Useful tips for the installing technician

- Before putting the appliance into operation, you must carried out scrupulously all the checks necessary for establishing conformity of the systems and installation of this appliance to the regulations and the technical and safety indications in the instruction manual.
- Inside there must be no plastic bags, instruction booklets, plastic films and so on.
- Make sure the tray support structure inside the cooking chamber is well secured to the walls. Otherwise, the trays containing food and hot liquids can fall and cause burns.
- All packaging must be thoroughly removed, including the protective film applied to the walls of the oven.
- The vents and the ventilation slots must be open and free from obstructions.
- The pieces of the oven eventually dismantled for installing must be refitted.
- We recommend connecting the oven to WI-FI and logging in to the CLOUD to install the latest update available. Alternatively visit the site and upload the update via USB.
- Turn on the oven for at least 10 minutes and ensure that the temperature rises, the steam works, that you can change fans speed and that chimney opening and closing operates properly.

ATTENTION: Wash the chamber before use (see instructions manual).

Customer service phone number:

URL to download updates through USB:

URL for connection to the CLOUD:

Dear Client, thank you and congratulations on buying this appliance; we are confident that this is the beginning of a positive and long-lasting collaboration.



GGM Gastro International GmbH
Weinerpark 16
D-48607 Ochtrup

www.ggmgastro.com

info@ggmgastro.com

+49 2553 7220 0