

# V 19.09

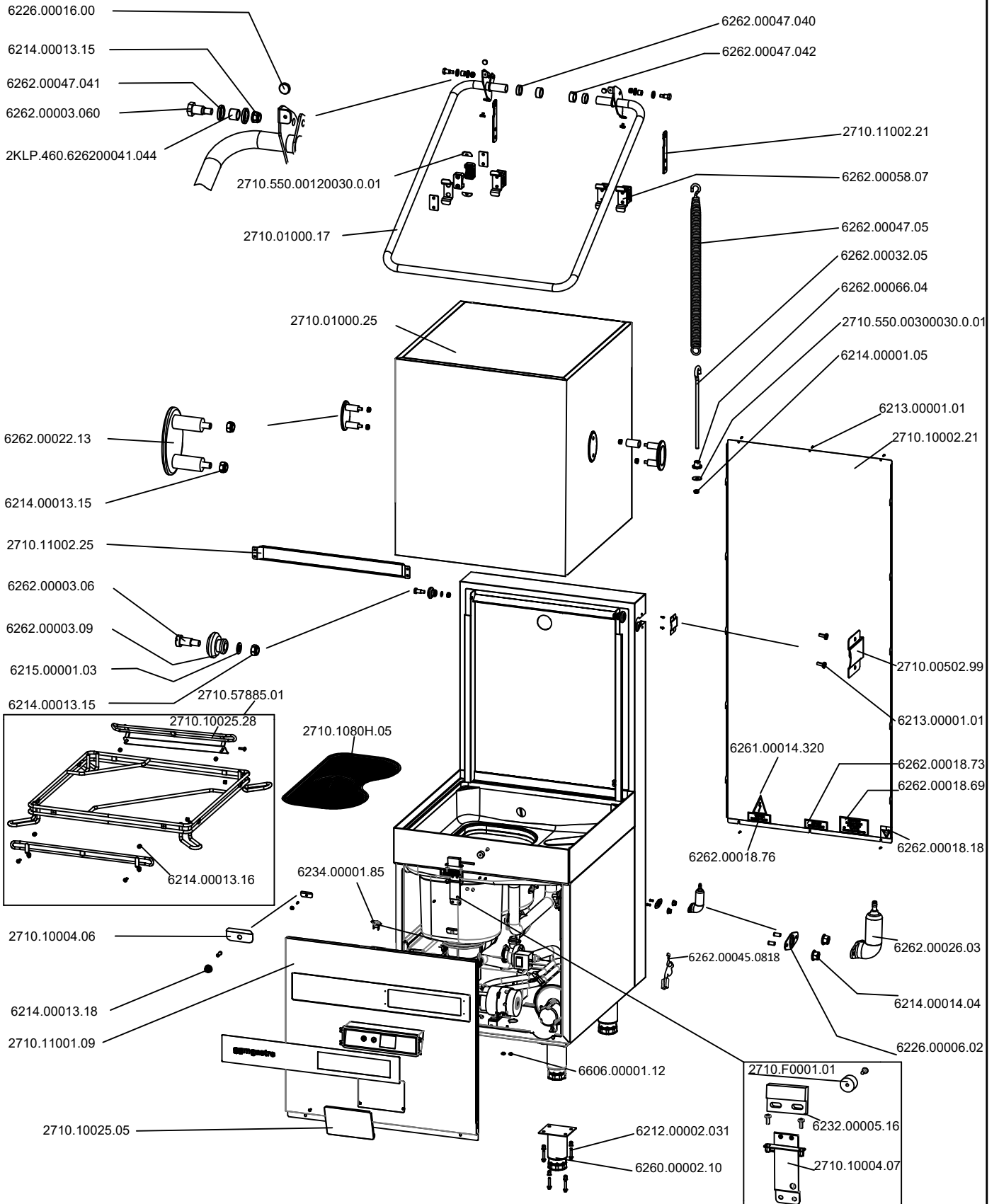

R&D	NAME	SIGNATURE	DATE	MATERIAL	VERSION NO	ggmgastro	
DRAWING	S.GURCU		05.05.2020		<b>V 19.09</b>	GROUP NAME: <b>BODY GROUP EXPLODED VIEW</b>	
CONTROL	S.GURCU		05.05.2020				
CONSENT	M.HACI		05.05.2020				
	MEASUREMENTS MILIMETER		WEIGHT (gr.)	THICKNESS	REVISION	SCALE	PICTURE NO

<b>Hood Type Dishwasher - Body Group</b>	
<b>Part Description</b>	<b>Part Code</b>
Hood H type hood body welded assembly	2710.01000.25
Handle spring plate blank filling part	6262.00047.041
Handle support plate blank filling part-right	6262.00047.042
Handle support plate blank filling part-left	6262.00047.040
Spring suspension bracket	2710.11002.21
Hood H type spring bushing part	2KLP.460.626200041.044
Handle cut cover	2710.00502.99
Rubber bumper	6226.00016.00
Clamp assembly for hood pipe arm Q25 polyemid	6262.00058.07
Hood H type Handle welded assembly	2710.01000.17
Hood handle side guide	6262.00022.13
Hood support bracket	2710.11002.25
Rear external cover	2710.10002.21
Hood pulley	6262.00003.09
Hood type rack holder	2710.57885.01
Magnet Group	2710.F0001.01
Door switch	6232.00005.16
CABLE FOR COVER SENSOR	6.262.000.450.818
Door switch and magnet group plate	2710.10004.07
Side complete in rack holder	2710.10025.28
M5 nylon insert lock nut	6214.00013.16
Stainless Steel Strainer with handle	2710.1080H.05
Hood sensor fixing plate	2710.10004.05
Hood H type spacer for hinges	2710.550.00120030.0.01
Hood spring	6262.00047.05
Bushing for spring hook tie-rod	6262.00066.04
Hook tie-rod for spring M10 partial threaded	6262.00032.05
washer for tie-rod	2710.550.00300030.0.01
Stainless steel leg 130-150 MM	6260.00002.10
Front panel	2710.11001.09
Detergent&rinse aid cover plate	2710.10025.05
Slide pulley bolt	6262.00003.06
Spring connection shaft	6262.00003.060
Air trap ( plastic )	6262.00026.03
Gasket for air trap	6226.00006.02
Detergent&rinse aid hose seal	6606.00001.12
M4x10 INOX PAN HEAD CROSS RECESSES SCREW	6213.00001.01
M5 hex nut with flange	6214.00014.04
M10 hex nut	6214.00001.05
M6x15 hex bolt with flange	6212.00002.031
M5x10 INOX PAN HEAD CROSS RECESSES SCREW	6213.00001.10
M6 washer supporting ring	6215.00001.02
M8 nylon insert lock nut	6214.00013.15
M8 washer supporting ring	6215.00001.03
M4 nylon insert lock nut	6214.00013.18
hood H type connection equipotential label	6262.00018.18
hood H type caution label 100x55mm	6262.00018.69
hood H type water discharge 80x30mm	6262.00018.73
hood H type for supply inlet cable 80x30mm	6262.00018.76
hood H type high voltage warning label 50x50mm	6261.00014.320
Thermostat prob fixing plate	2710.10004.06

# V 19.09

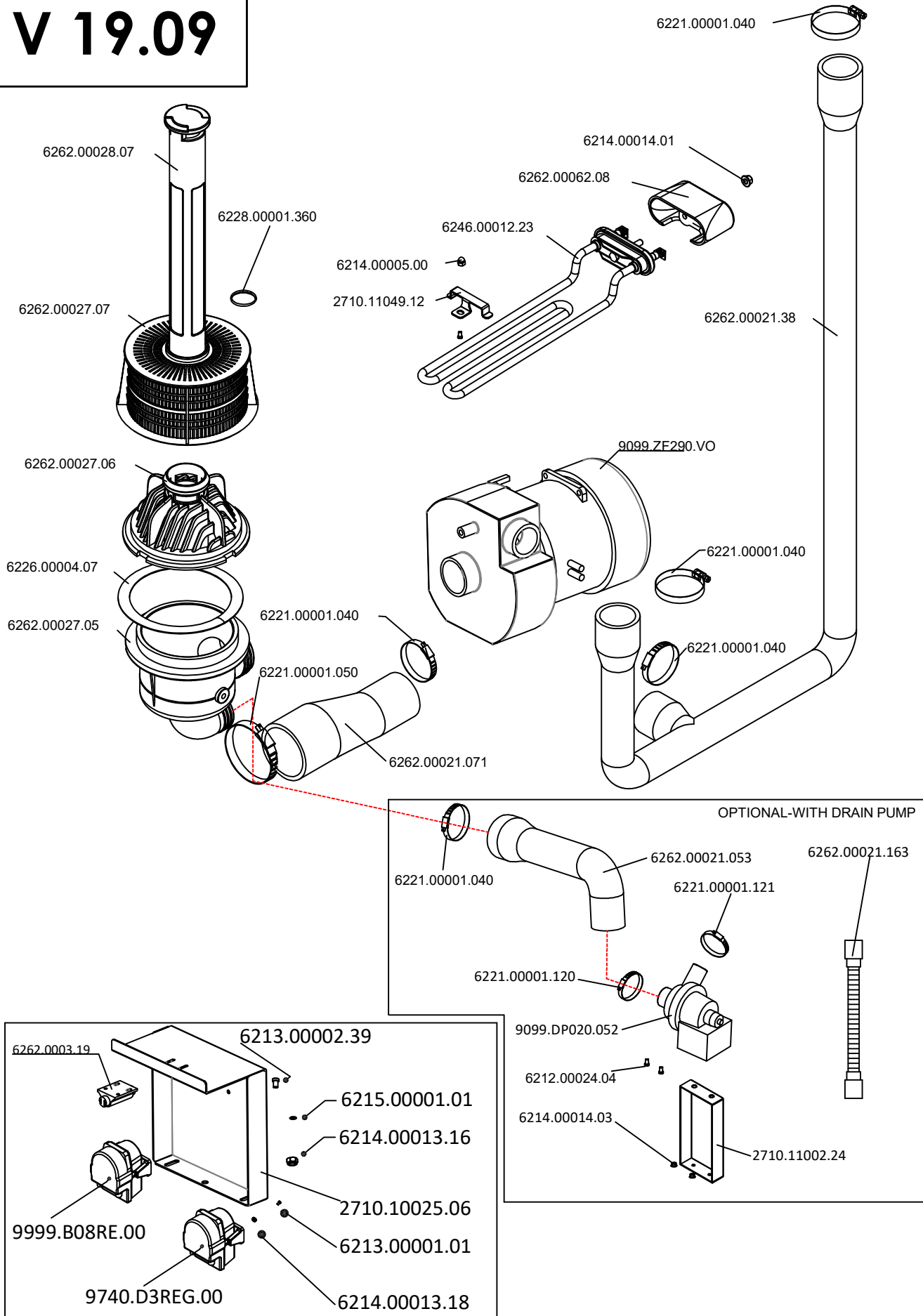

R&D	NAME	SIGNATURE	DATE	MATERIAL	VERSION NO	ggmgastro	
DRAWING	S.GURCU		05.05.2020		<b>V 19.09</b>	GROUP NAME: WASHING GROUP EXPLODED VIEW	
CONTROL	S.GURCU		05.05.2020			REVISION	
CONSENT	M.HACI		05.05.2020	THICKNESS		SCALE	PICTURE NO
MEASUREMENTS MILIMETER				WEIGHT (gr.)			

<b>Hood Type Dishwasher- Washing Group</b>	
<b>Part Description</b>	<b>Part Code</b>
Hood H type drain plug	6262.00028.07
Drain plug o-ring	6228.00001.360
Suction filter top part	6262.00027.07
Suction filter center part	6262.00027.06
Suction filter seal	6226.00004.07
Suction filter lower part	6262.00027.05
Hose clamp 50-70 mm	6221.00001.050
Hose clamp 40-60 mm	6221.00001.040
Washing pump connecting Hose	6262.00021.071
Washing Pump	9099.ZF290.V0
M8x15 hexagon screw	6212.00002.17
M8 hex nut with flange	6214.00014.00
Hood type washing distribution hose	6262.00021.38
Tank heater fixing plate	2710.11049.12
Washing Tank heater 2000W 230V	6246.00012.23
Washing tank heater cover	6262.00062.08
M5 domed cup nut	6214.00005.00
M6 hex nut with flange	6214.00014.01
Detergent and Rinse aid fixing plate	2710.10025.06
M5*10 stud bolt inox	6213.00002.39
Open-Close mechanism of Detergent and Rinse aid fixing plate	6262.0003.19
Washer	6215.00001.01
M5 nylon insert lock nut	6214.00013.16
M4x10 INOX PAN HEAD CROSS RECESSES SCREW	6213.00001.01
RINS-AID PUMP	9999.B08RE.00

# V 19.09

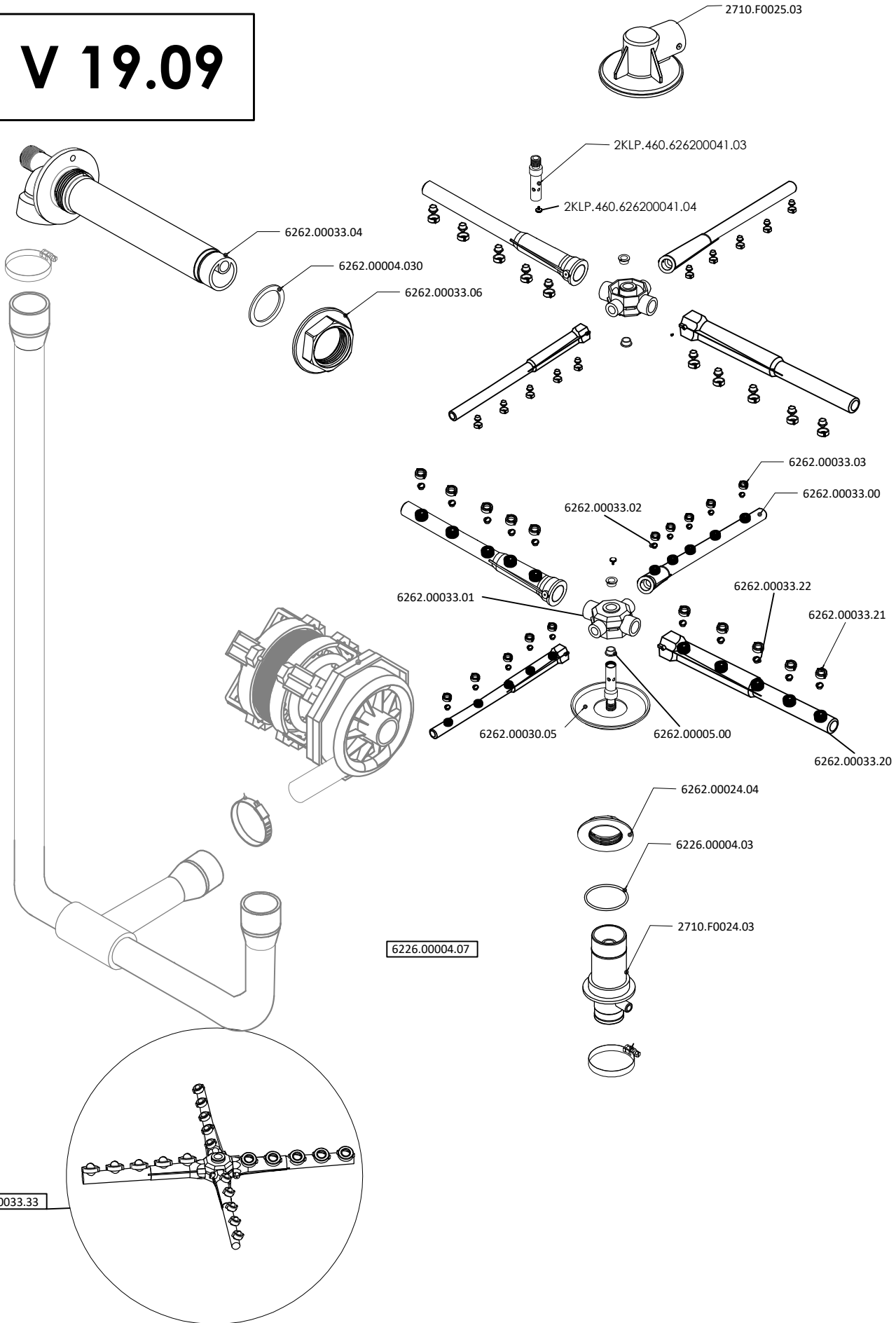

R&D	NAME	SIGNATURE	DATE	MATERIAL	VERSION NO	ggmgastro	
DRAWING	S.GURCU		05.05.2020		<b>V 19.09</b>	GROUP NAME: <b>SPRAY ARM GROUP EXPLODED VIEW</b>	
CONTROL	S.GURCU		05.05.2020				
CONSENT	M.HACI		05.05.2020	THICKNESS	REVISION		
MEASUREMENTS MILIMETER			WEIGHT (gr.)	SCALE	PICTURE NO		

<b>Hood Type Dishwasher - Spray arm Group</b>	
<b>Part Description</b>	<b>Part Code</b>
Water inlet bottom	2710.F0024.03
Water inlet elbow top	2710.F0025.03
Water inlet nut bottom	6262.00024.04
Water inlet seal bottom	6226.00004.03
Washing Hose Top Part (PP)	6262.00033.04
Washing Hose Top Part Seal	6262.00004.030
Washing Hose Top Part Nut	6262.00033.06
Washing Hose	6262.00021.37
Clamp 1	6221.00001.050
Clamp 2	6221.00001.030
Clamp 3	6221.00001.040
Washing Arm	6262.00033.33
Washing Arm (Without Nut&Nozzle)	6262.00033.00
Washing Arm Nozzle	6262.00033.03
Washing Arm Nut	6262.00033.02
Rinsing Arm(Without Nut&Nozzle)	6262.00033.20
Rinsing Arm Nozzle	6262.00033.21
Rinsing Arm Nut	6262.00033.22
Collector(washing&rinsing)	6262.00033.01
Washing Arm Part (Plastic Part)	6262.00005.00
Water inlet part bottom	6262.00030.05
Navel axle	2KLP.460.626200041.03
Special Screw M8	2KLP.460.626200041.04

# V 19.09

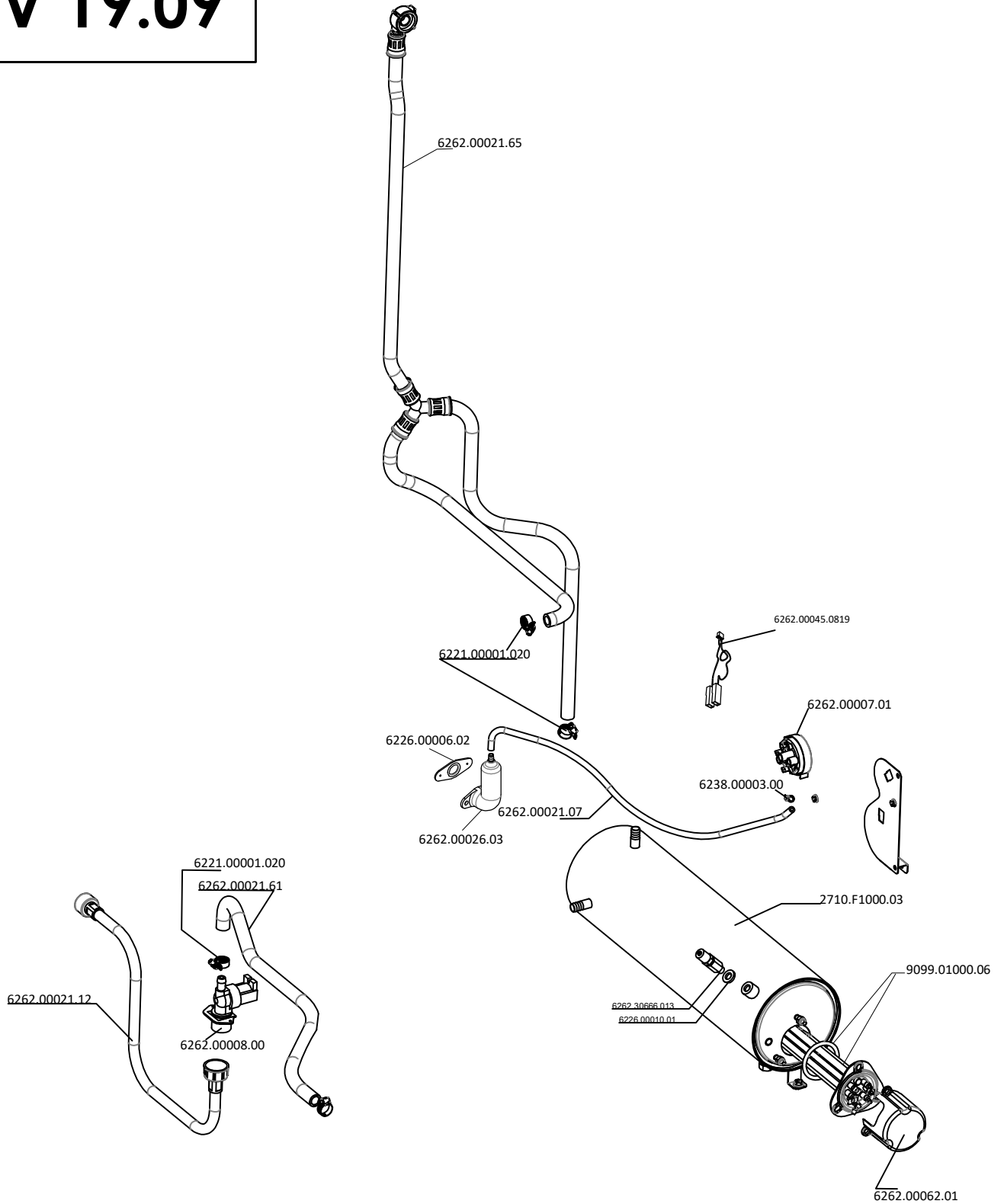

R&D	NAME	SIGNATURE	DATE	MATERIAL	VERSION NO	ggmgastro	
DRAWING	S.GURCU		05.05.2020		V 19.09	GROUP NAME:	
CONTROL	S.GURCU		05.05.2020			RINSING GROUP EXPLODED VIEW	
CONSENT	M.HACI		05.05.2020	THICKNESS	REVISION	SCALE	PICTURE NO
MEASUREMENTS MILIMETER			WEIGHT (gr.)				

<b>Hood Type Dishwasher - Rinsing Group</b>	
<b>Part Description</b>	<b>Part Code</b>
Rinsing Hose	6262.00021.65
Pressure Switch	6262.00007.01
Pressure Switch Connection Hose	6262.00021.07
Air Gap Seal	6226.00006.02
Air Gap	6262.00026.03
Hose	6262.00021.61
Supply Hose	6262.00021.12
Water Inlet Valve	6262.00008.00
Resistance 9000 W	9099.01000.06
Boiler Body	2710.F1000.03
Rinse-aid connection check valve	6262.30666.013
Klinger gasket 1/2"	6226.000010.01
Clamp 12*20 mm	6221.0001.020
Hose 42 cm	6262.00021.61
Pressure switch connection cable	6262.00045.0819
Hose	6262.00021.47

# V 19.09

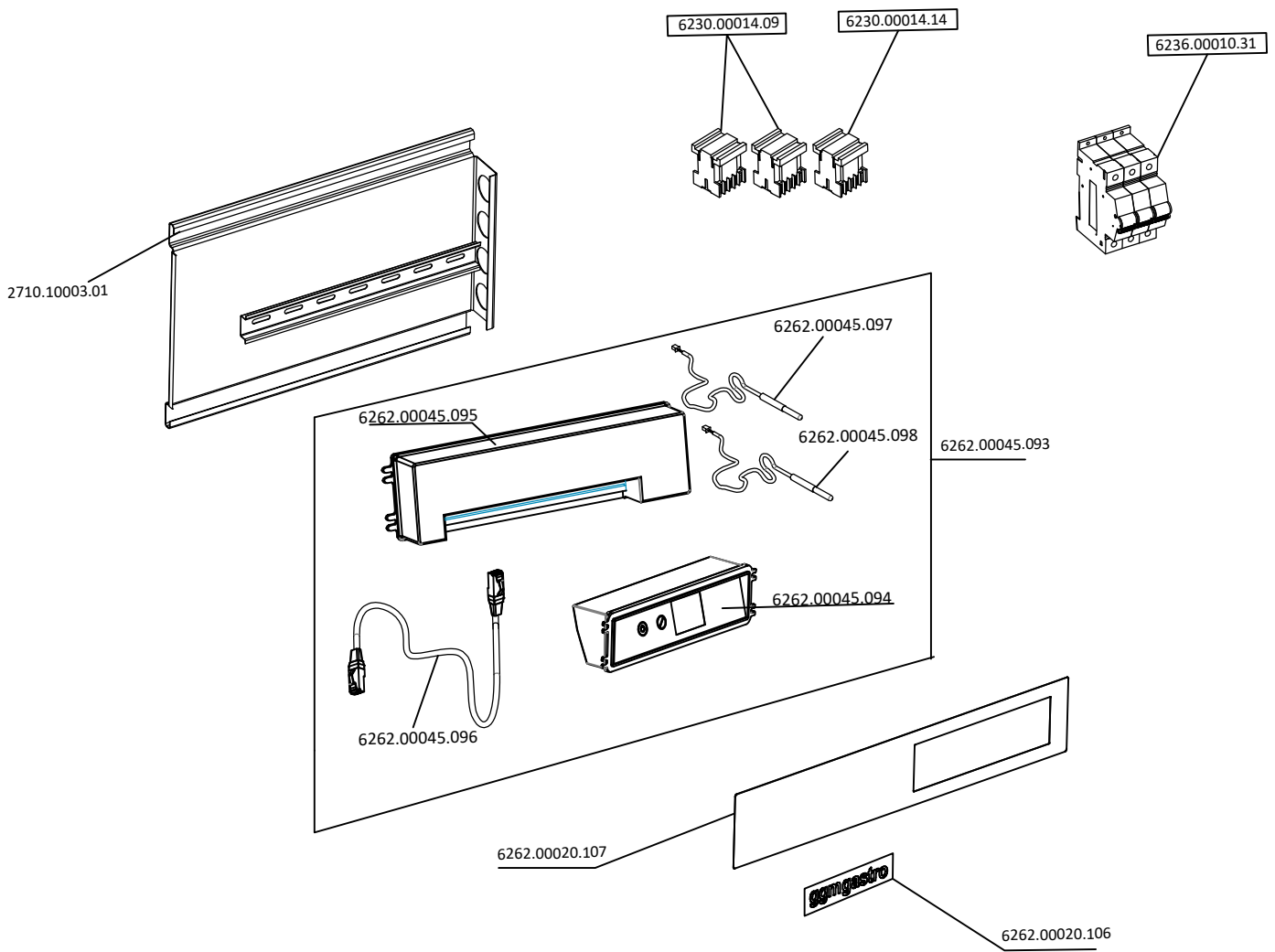

R&D	NAME	SIGNATURE	DATE	MATERIAL	VERSION NO	ggmgastro		
DRAWING	S.GURCU		05.05.2020	/	<b>V 19.09</b>	GROUP NAME: <b>ELECTRICAL GROUP EXPLODED VIEW</b>		
CONTROL	S.GURCU		05.05.2020			THICKNESS	REVISION	PICTURE NO
CONSENT	M.HACI		05.05.2020			WEIGHT (gr.)	SCALE	
			MEASUREMENTS MILLIMETER					

### Hood Type Dishwasher- Electrical Group

<b>Part Description</b>	<b>Part Code</b>
Control Group ( 6262.00045.094-95-96-97-98 )	6262.00045.093
Digital screen	6262.00045.094
Power box	6262.00045.095
Data cable	6262.00045.096
Boiler prob	6262.00045.097
washing tank prob	6262.00045.098
LABEL	6262.00020.106
LOGO	6262.00020.107
Electrical panel plate	2710.10003.01
Contactora (DILM 10)	6230.00014.09
Contactora (DILM 12-01)	6230.00014.14
Automat C CLS4-C25/3 (3x25A)	6236.00010.31



GGM Gastro International GmbH  
Weinerpark 16  
D-48607 Ochtrup

[www.ggmgastro.com](http://www.ggmgastro.com)

[info@ggmgastro.com](mailto:info@ggmgastro.com)

+49 2553 7220 0