

# Blast Freezer Control Panel

## ELIWELL BLAST CHILLER/FREEZER MANUAL

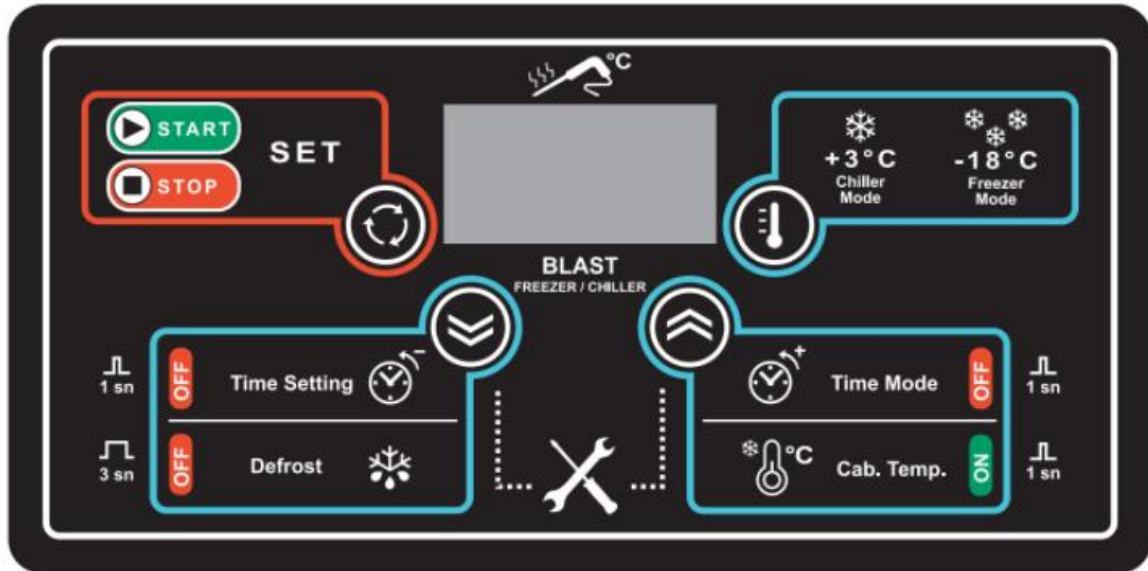

### ABOUT BLAST FREEZER/CHILLER:

Regarding the modern technological possibilities, the highest level of quality could be achieved using freezing, blasting and deep-freezing where the food is reserved safe for storage and later consumption. Blast freezing is commonly used in food catering and, recently, in the preparation of 'instant' foods, as it ensures the safety and the quality of the food product.

The main principle of using Blast-Freezing method is to freeze the food from 100° C to -18° C in 240 minutes so that activity and growth of microorganisms may be prevented which causes rinsing of the food. This is called Blast Freezing. Also, reduce the core temperature of the food from 100° C to +3° C in 90 minutes is called Blast Chilling.

### GENERAL INFORMATION:

This manual is an integral part of the product, providing all the information required to ensure correct installation, operation and maintenance of the machine.

Read the manual carefully, making reference to it for machine operation. Keep the manual in a safe place where it can be accessed by all authorized operators (installers, operators and service personnel).

The machine has been designed for professional applications only and should only be operated by qualified personnel.

The machine must only be used for the purposes for which it was designed, i.e. for chilling and freezing food products.

The machine must not be used for products requiring constant temperature control and recording, such as:

- Heat-sensitive chemicals
- Medicines
- Blood products

The manufacturer declines all responsibility for any damage caused by incorrect or unreasonable machine use, such as:

- Improper use by untrained persons;

- Technical modifications or operations not suited to specific models;
- Use of non-original or non-specific spare parts;
- Failure to follow the instructions given in this manual.

Concerning and using the appliance should be by a person responsible for his/her safety. Children should be supervised to ensure that they do not play with the appliance.

### **INSTALLATION:**

The machine must be installed by a specialized technician authorized by and in compliance with the instructions given in this manual.

### **TRANSPORT AND HANDLING:**

To load or unload the machine and/or components from/onto the means of transport, use a lift truck or fork lift equipped with forks that are at least half the length of the machine housing; use a crane if the machine is fitted with eye bolts. Select the lifting equipment suited to the weight and overall dimensions of the packaged machine/components. During the transportation, close the door and fix the wheels and all components.



### **1- UNPACKING:**

Remove all cardboard, wood or other materials from the wood base on which the machine is set. Lift the machine/ components with suitable means (e.g. lift truck), remove the wood base then position the machine / components in the allocated site.

- Once all packing material has been removed, check that the machine has not been damaged in any way.
- remove the protective PVC film on the stainless steel panels from all internal and external surfaces.



**GENERAL SAFETY REGULATIONS:**

Failure to observe the recommendations made by the present manual will be at the entire responsibility of the machine user. The main safety regulations are as follows:

- Do not touch the machine with moist or wet hands or feet;
- Never operate the machine while barefoot;
- do not insert screwdrivers, cooking utensils or any other object between the guards and moving parts;
- Before performing cleaning or routine maintenance operations, disconnect the machine from the power supply at the master switch and the main knife switch (if present);
- Never pull on the power cable to disconnect the machine from the power supply.

**THESE OPERATIONS MUST BE PERFORMED BY A CERTIFIED INSTALLATION TECHNICIAN ONLY.**

**PLAQUES**

Check that the data specified on the plate correspond to the characteristics of the power supply (V, kw, hz, no. phases and power available).

<b>CE</b>		
<b>Model</b>	<b>VBL-5</b>	
<b>Product code</b>	<b>MVBL-20B04L</b>	
<b>Volt./Ten. (V/Hz)</b>	<b>220-240</b>	<b>50</b>
<b>Storage Volume</b>	<b>135 Lt.</b>	
<b>Current (A)</b>	<b>6.7 A</b>	<b>-10 / -22</b>
<b>Power (KW)</b>	<b>1.20</b>	<b>55 dB</b>
<b>Ref. / Weight (Kg)</b>	<b>R404a</b>	<b>0.5</b>
<b>Product M/Y</b>	<b>02</b>	<b>2016</b>
<b>Serial Number</b>	<b>602244 VBL5</b>	
 <b>602244VBL5</b>		

### **POSITIONING:**

The machine must be installed and commissioned in complete compliance with safety regulations, procedures and standing laws. The installation technician bears the responsibility of ensuring compliance with fire safety requirements; seek all necessary advice from the local fire-fighting authorities. Position the machine in the allocated site. Adjust the machine feet until the appliance is perfectly level. In the case of particularly heavy equipment, use appropriate lifting means. If the appliance is not perfectly level, correct operation and condensate flow-off will not be assured.



### **AVOID:**

- o Direct exposure to sunlight;
- o Closed sites with high temperatures and poor air circulation;
- o Installing the machine near sources of heat.

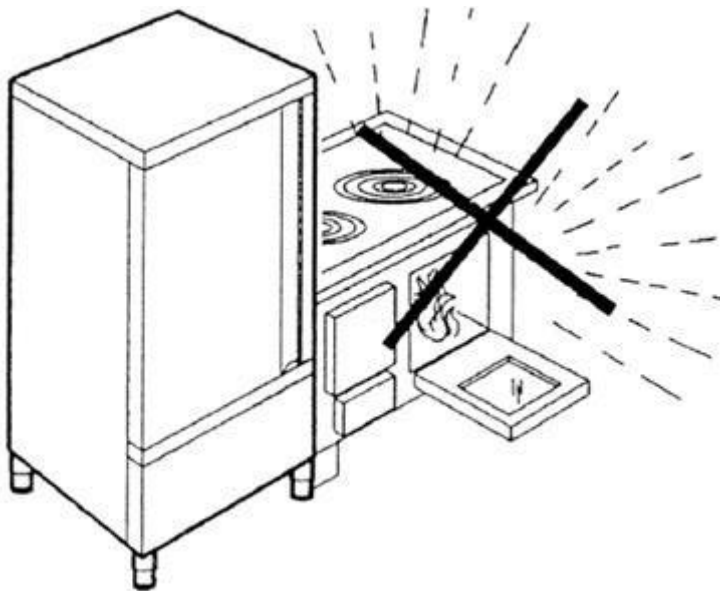

### **AMBIENT TEMPERATURE AND AIR CIRCULATION:**

For air-cooled appliances, the maximum ambient temperature for operation is 32°C. Correct operation cannot be guaranteed at higher temperatures. The machine may operate safely to a maximum temperature of 38°C. Remote condensing units must be installed in special rooms or outdoors, protected against direct sunlight by a shelter or roof structure (at the cost of the purchaser). Sufficient air circulation must be guaranteed at all times.

### **CONDENSATE DRAINAGE CONNECTION**

Fit a condensate/wash water drainage hose as picture or use water box tray under the refrigerator.

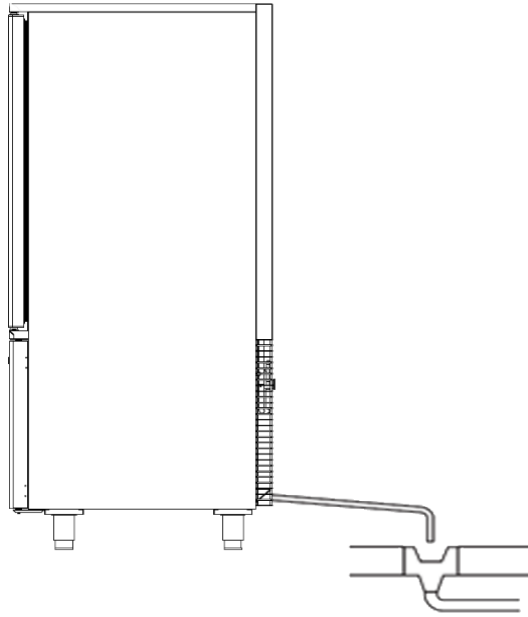

### **SHUT DOWN PROCEDURES**

In the event of emergency, remove the plug from the power socket.

### **OPERATING TIPS**

Before starting up the appliance, clean the inside of the cell thoroughly.

### **PRE-COOLING**

Before using the appliance for the first time, or after a prolonged period of disuse, pre-cool the cell by running an empty cycle until the set operating temperature has been reached. To ensure optimal performance without any alteration to food quality:

Arrange food products in such a way as to favor the circulation of cold air throughout the cell;

Open the door as little as possible.

### **LOADING THE APPLIANCE**

Ensure that foods to be chilled and/or frozen are separate and do not have a thickness greater than 50-80 mm. Do not load the appliance beyond the quantity recommended by the manufacturer.

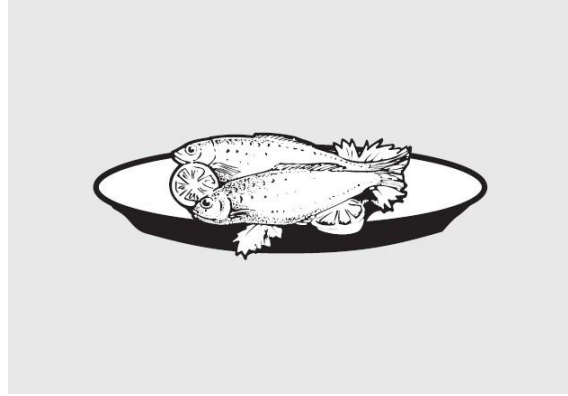
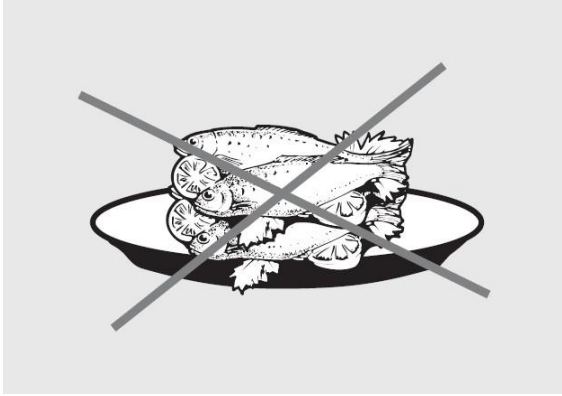

Ensure that there is sufficient clearance between trays to enable free air circulation. If the appliance is not completely full, distribute the trays and foods evenly throughout the available space.

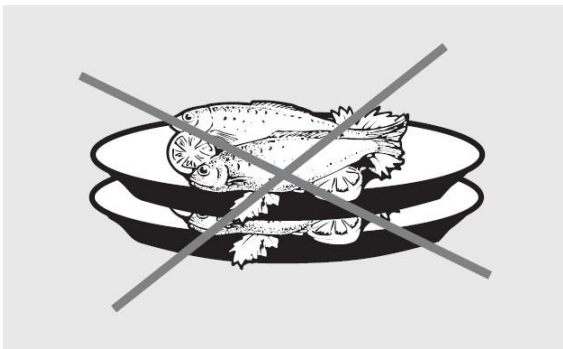

Position trays inside the tray compartment as far as they will go, as close as possible to the evaporator.

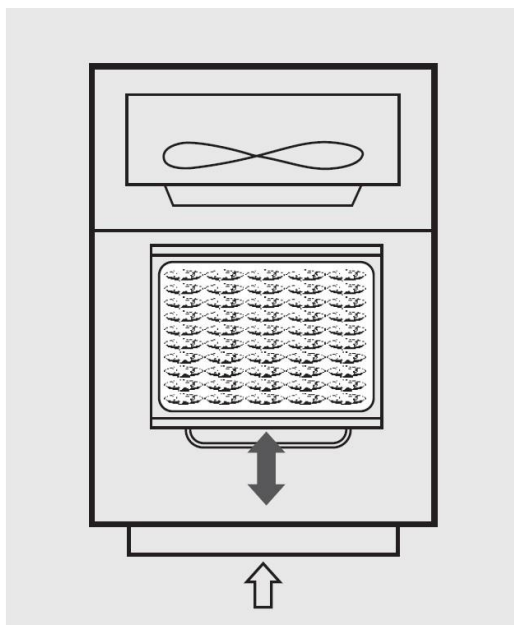
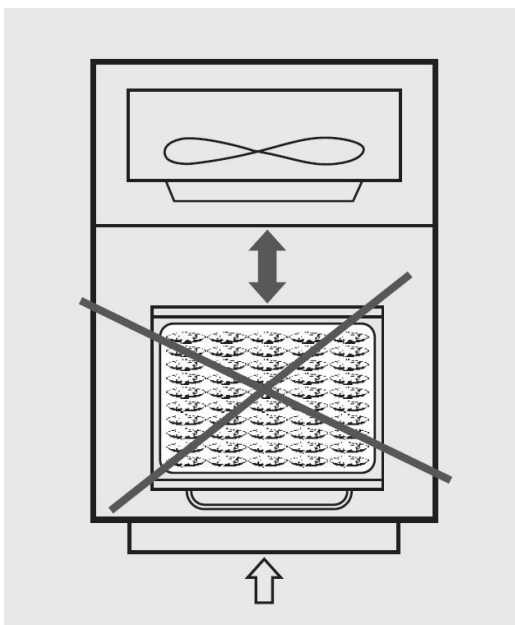

Position the core probe at the center of the largest product or food item; make sure that the tip of the probe does not protrude or touch the tray. The probe must be cleaned and sanitized before each new cycle (operation) to prevent inadvertent contamination.

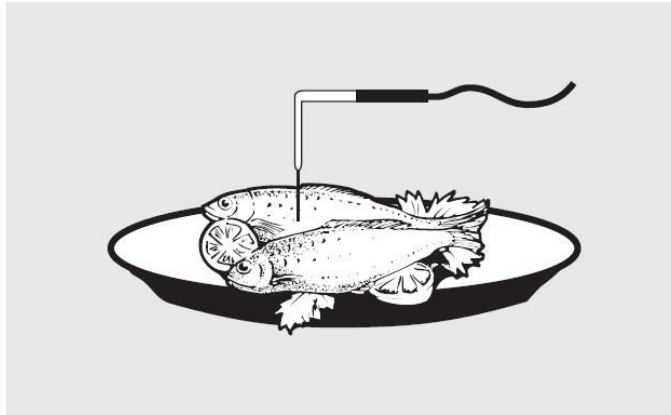

Avoid covering the trays and/or containers with insulating covers or film. The more the product is insulated, the more time is required for chilling or freezing. Trays must be packaged when the product has been chilled, before being placed in storage.

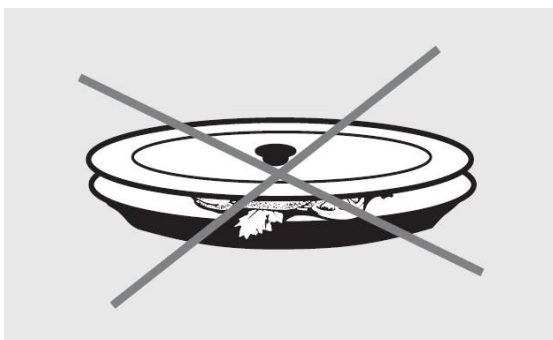
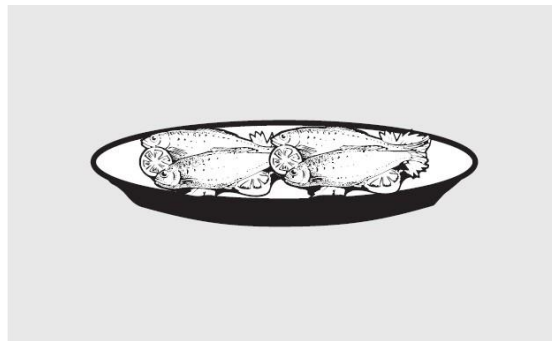
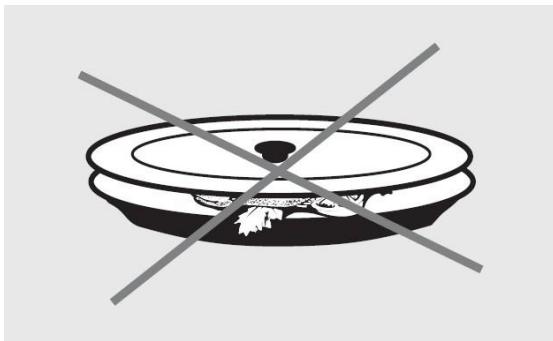







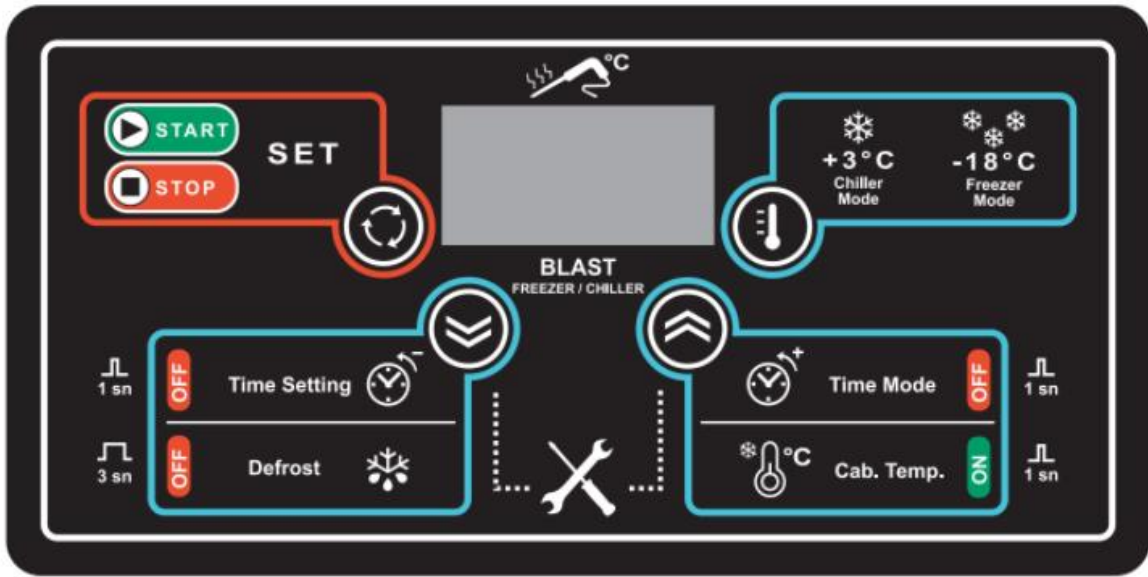











**IMPORTANT WARNING:**







**THE DIGITAL PARAMETER SETTING HAS BEEN PROGRAMMED FOR THE UNIT TO PERFORM THE BEST WAY. DO NOT CHANGE ANY OF THE PARAMETER SETTING OTHER THEN SIMPLY SETTING THE TEMPERATURE. TO CHANGE THE PARAMETERS SETTINGS CAN CAUSE SERIOUS PERFORMANCE DECRESAES AND CREATE SERIOUS PROBLEMS IN THE UNIT.**

ELIWELL BLAST CHILLER/FREEZER MANUAL

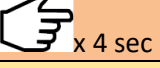

Key	Description of Key	Symbol associated with key	Symbol Description
	<b>SET</b> Blast chiller start/stop operation and confirmation		Blast Chiller Operation Start
			Blast Chiller Operation Stop
		<b>SET</b>	Confirm
	<b>DOWN</b> Decrease in value, Buzzer switch off and defrost activation		Defrost
			Buzzer Switch off
			Value Decrease
	<b>UP</b> Value increase, cold room temperature display, load activation on auxiliary output		Value Increase
			UV Lamp for Sterilization
			Needle Probe Heater
	<b>SEL</b> Program selection and stand-by enable		Positive Blast Chilling
			Negative Blast Chilling
/	/		Key Press and Hold (4 sec)
			Key Short Press
			Simultaneous pressing of <b>Down</b> and <b>Up</b> keys
			Parameters configuration

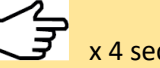
## Keys

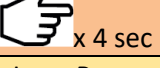
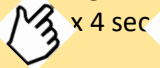
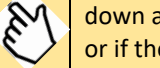
Naming	Mode	Description
SET	Short Press 	Blast chiller start/stop operation and confirmation
DOWN	Short Press 	Slow decrease of the value and buzzer switch off During a program it displays the cold room probe temperature
	Long Press  x 4 sec	Fast decrease of the value and defrost activation
UP	Short Press 	Slow increase of the value and cold room temperature display
	Long Press  x 4 sec	Fast increase of the value and load activation on the auxiliary output (UV lamp for sterilization, needle probe heater or auxiliary condenser fan)
SEL	Short Press 	Program selection alternately positive and negative
	Continuous Press 	Display of the elapsed time from the blast chilling cycle beginning or the duration of the blast chilling cycle until the key is released
	Long Press  x 4 sec	Stand by enable
DOWN + UP	Long Press  x 4 sec  x 4 sec	To access to configuration parameters simultaneously press the down and up key for 4 seconds. (Only with blast chiller in stop phase or if there are no programs in progress).

Part No	Alarm	Cause	Effects	Solutions
Er1*	Needle Probe Error	Needle Probe not Connected Properly	If an automatic program is in progress, switch to manual program.	Check the connection of the needle probe to the EWBC1400
		Faulty Needle Probe		Replace the needle probe
Er2*	Cold Room Probe Error	Cold Room Probe not Connected Properly	If a manual program is in progress with the presence of the needle probe (parameter P3=1), the manual program continues using the needle probe as a cold room probe If a manual program is in progress with the absence of the needle probe (parameter P3=0), manual program stops If an automatic program is in progress, the automatic program stops	Check the connection of the cold room probe to the EWBC1400
		Cold room Probe Failure		Replace the cold room probe
Er3	Condenser Probe Error	Condenser Probe Not Connected Properly	/	Check the connection of the condenser probe to the EWBC1400
		Condenser Probe Failure		Replace the condenser probe
Er4	Auxiliary Condenser Probe Error	The Auxiliary Condenser Probe is not Connected Properly	/	Check the connection of the auxiliary probe to the EWBC1400
		Auxiliary Condenser Probe Failure		Replace the auxiliary probe
dOr	Door Open	Blast Chiller Door Opening with Program or Special Funcion (except the defrost) in Progress	Cold room fan deactivation compressor deactivation (if parameter P6=0)	Close the blast chiller door to normally resume the program
PrS	Pressure Switch Alarm Without Loads Locking	- Opening of the pressure switch DI2 (if parameter P27 is 0) - Pressure switch alarm events counting <parameter P27	Increase of one unit of the alarm counter (initially zero) Blast chiller in stand-by status: - compressor deactivation (OUT1) - cold room fan deactivation (OUT2) - condenser fan activation (OUT3) - auxiliary fan activation (OUT4), if parameter P23=3 - time counting stand-by, if a manual program is in progress	Close the pressure switch DI2 and wait the safety times of the compressor (parameter P 9 and parameter P10)
	Pressure Switch Alarm with Loads Locking	- Opening of the pressure switch DI2 (if parameter P27 is other than 0) - Pressure switch alarm events counting =parameter P27	Deactivation of all loads (OUT1, OUT2, OUT3, OUT4)	Press the SET key

**IMPORTANT WARNING:**

**THE DIGITAL PARAMETER SETTING HAS BEEN PROGRAMMED FOR THE UNIT TO PERFORM THE BEST WAY. DO NOT CHANGE ANY OF THE PARAMETER SETTING OTHER THEN SIMPLY SETTING THE TEMPERATURE. TO CHANGE THE PARAMETERS SETTINGS CAN CAUSE SERIOUS PERFORMANCE DECRESAES AND CREATE SERIOUS PROBLEMS IN THE UNIT.**

**PLUG IN THE PRODUCT. YOU WILL SEE HOLD ALARM ON DISPLAY. (ONLY ON THREE-PHASE 380 V UNITS). YOU CAN START THE FREEZING/CHILLING OPERATIONS IN 45 MINUTES.**



GGM Gastro International GmbH  
Weinerpark 16  
D-48607 Ochtrup

[www.ggmgastro.com](http://www.ggmgastro.com)      [info@ggmgastro.com](mailto:info@ggmgastro.com)  
+49 2553 7220 0