

# DRY AGE USER MANUAL



This detailed guide contains important information for the effective and safe use of DRY AGE. In case of any problems, assistance should be sought from an expert technician.

## 1. Safety;

Users should read the information provided in this user manual very carefully. Also, given security warnings definitely literally in its place should bring.

The following measures it's too much to take it is important.

Place on a flat and stable surface. Do not use pressure washers to clean the device.

Do not use this device to store medical supplies. Do not allow oil or grease inside the device to come into contact with plastic components or the door seal. Always switch off and disconnect the power supply before cleaning the device.

### 1.1. General Information;

This section provides an overview of all important safety topics. If the safety instructions are followed, optimum protection against all hazards and trouble-free operation are guaranteed. This device is designed in accordance with the latest technology. However, if the device is used incorrectly and not for its intended purpose, dangers may occur. Protect yourself from dangers

It is important to know the contents of the user manual to avoid mistakes and to operate the device safely and without errors.

To avoid hazards and ensure optimum performance, no modifications or modifications should be made to the device that are not expressly approved by the manufacturer.

### 1.2. Introduction;

Please take a few minutes to read this manual carefully. Proper maintenance and operation of this device will ensure the best possible performance from your product.

### 1.3. Package Contents;

#### 1.3.1. Packaging, Storage, Disposal of Electrical and Electronic Products;

Before installation, completely remove the outer and inner packaging material from the unit. Check that the device is complete and if any part is missing, contact the customer representative immediately.

When disposing of packaging, comply with the regulations in force in your country. Recycle reusable packaging materials.

#### Correct Disposal of This Product (Waste Electrical and Electronic Equipment)

(Valid in the European Union and other European countries with separate collection systems)



This marking shown on the product or its literature indicates that it should not be disposed of with other household waste at the end of its useful life.

To prevent potential environmental or human health harm from uncontrolled waste disposal, please separate it from other types of waste and recycle it responsibly to promote the sustainable reuse of material resources.

This product should not be mixed with other commercial waste for disposal but should be returned to a waste collection centre.

### 1.4. Installation;

**Note:** If the device has not been stored or transported in an upright position, ensure that it stands upright for approximately

12 hours before operating.

**1-** Remove the device from its packaging and ensure that all protective coating materials are removed from all surfaces.

**2-** Place the device on a flat and solid surface.

### 1.5 DOCUMENTS;

The working system of the DRY AGE product is produced and documented in accordance with European Standards (CE).

### 1.6 WARRANTY;

A new product is under warranty for 2 years.

**Attention:** Before performing any intervention on the product, the User and the Technician must read this user manual carefully. Otherwise, the product may be out of warranty.

### 2. UV-C Sterilization:

There is a UV-C light in the device to prevent the formation of harmful mold and bacteria. This light is positioned in a place where the user cannot come into direct contact.

The device also performs a sterilization process during defrosting. This process takes 5 times a day and approximately 10 minutes.

### 3. Descriptions and Device Use;

#### 3.1. First Use:

Clean the inside of the appliance before operating it. Use chemical-free cleaners suitable for food contact for cleaning. Run the refrigerator empty for 24 hours. This process is necessary for the device to become stable.

#### 3.2 General Description:

Scientifically, in molecular gastronomy, "meat cooking techniques and tenderization" are the main subjects on which basic studies are made. After an animal is slaughtered, its meat begins to harden. This hardness, called rigor mortis, can be reduced by 80% with an aging process that lasts for days.

The basis of the Dry Age application is as follows;

**Meat** is kept under storage and observation in a very clean, odorless environment with a temperature of 1°C and a humidity of 65 ± 10%. If the constant temperature changes, for example, if it is warmer, the meat may spoil, if it is below 0°C, the meat freezes and the aging process ends. The changes on the meat with the aging process are as follows;

**1-** A dark brown and hard layer is formed by the enzymes on the outside of the meat. Inside, the enzymes continue their work and the meat becomes lighter as it loses some moisture. This development allows the taste of the meat to become more intense. In addition, with the time spent for aging, the enzymes break down the connective tissues in the muscles and make the meat softer. When you cut the dark brown layer on the outside, you will see the bright red meat inside. This meat is the more delicious and soft rested meat.

**2-** In short, the Dry Age process is the resting of the meat in the refrigerator in a healthy environment without producing bacteria and presenting it to the customer in a delicious way. In order for Dry Age cabinets to provide a healthy product, the product must be fresh and the temperature of the meat must be reduced to a maximum of 2°C to 5°C in the cold room before being placed in the cabinet.

Make sure that the meats do not come into contact with each other. Contact can prevent air circulation and reduce the aging quality. If you are aging different types of meat together, check the optimum aging temperature and humidity requirements for each type of meat.

### 3.4. Temperature and Humidity Setting:

**Temperature:** The ideal temperature of the refrigerator should be between 0 - 1°C. You can adjust the temperature via the refrigerator control panel. Temperature changes may be required depending on the type of meat.

**Humidity:** Set between 65% - 85%. Humidity level is very important for proper aging of meat. Humidity level is a critical factor to prevent meat from drying out and optimize the aging process. If humidity level is low, check the humidification system of the device. Read the humidifier control section.

### 3.5. Air Circulation:

The fan system in the cabinet ensures that the air circulates and distributes the meat evenly on all sides. Make sure that the fan is working properly and that it is not rubbing anywhere.

### 3.6. Meat Aging Period and Storage Details:

Depending on the type of meat and the desired flavor level.

The aging period can vary from 14 to 60 days. Open the refrigerator door as little as possible during this period. The color, texture and smell of the meat should be checked throughout the aging period. If anything unusual is noticed, check the device settings or environmental conditions.

#### For example;

**Beef:** It is usually aged for 21-45 days. During this process, the color of the meat darkens, its texture becomes softer and a unique aroma develops.

**Lamb:** It can be stored for 14-28 days. Lamb meat requires a lighter aging process and reaches the desired softness in a shorter time.

**Game Meat:** It can be aged for 30-60 days. Game meat has a denser texture. It may need a long aging process.

### THINGS TO CONSIDER TO PRESERVE THE QUALITY OF MEAT:

**Color Change:** The color of the meat changes from red to dark during the aging process. This is a natural process.

**Odor:** The odor of aged meat is intense and aromatic. However, if you notice a sharp or unpleasant odor, check the meat before using it.

**Surface Dryness:** Dryness may occur on the surface of the meat during aging. This is normal and the hard layer on the surface can be cleaned before cooking.

**Humidity Level:** Keep the humidity level under control to prevent the meat from drying out. Excessive humidity can cause mold growth. Therefore, regular control is important.

### 4. Maintenance and Cleaning

clean the inner and outer surfaces of the cabinet with a damp cloth.

Take care to clean the door seals, this area is sensitive to dust

and dirt accumulation. Clean after each use to prevent this accumulation. Check the humidity chamber and add water if necessary.

#### Salt Care:

Salts in the device may melt over time and form white spots. Clean these spots with sandpaper and wipe the salt residue from inside the cabinet with a damp cloth.

#### Annual Maintenance:

Have the general maintenance of the device done by an authorized service. This process will extend the life of the device.

#### Humidification Unit Usage:

The amount of water in the unit should be checked regularly every week.

If the humidity level of the device is low, add water from the manual water filling area on the humidification unit.

#### How Much Water is Added to the Water Reservoir in Dry-Age Cabinets?

The amount of water to be added to the water tank in dry-age cabinets should generally be taken into account in the following criteria:

##### 1. Standard Water Quantity

Generally, adding 1.5-2 liters of water is sufficient.

##### 2. Control of Water Level

In the water tank of the dry-age cabinet. Be careful not to overflow when adding water.

The humidity level should remain constant between 55-75%. If you have a digital hygrometer in your closet, adjust the water level according to this value.

##### 3. Water Type and Quality

It is recommended to use purified water: Tap water can cause damage to the internal system of the cabinet by causing lime and mineral deposits.

Water Must Be Renewed Regularly: Hygiene must be ensured and mold formation must be prevented by changing the water every week.

##### 4. How Do You Know If Water Is Depleting?

If the humidity level inside the cabinet drops below 55%, you will need to add water to the water tank.

If the water level is depleting very quickly, the ambient temperature may be too low or the air circulation inside the cabinet may be too much.

##### 5. What Happens If Too Much Water Is Added?

Excessive humidity (90% and above) can lead to mold and bacteria formation.

An unwanted layer may form on the outer surface of the meat.

If the fan or air circulation inside the cabinet does not work properly, condensation and dripping may occur.

Humidity level should be kept between 55-75%.

Purified water should be preferred.

It is recommended to change the water regularly.

**WARNING: IF THE POWER CABLE IS DAMAGED, ONLY THE MANUFACTURER'S SERVICE OR A QUALIFIED PERSONNEL MAY REPLACE THIS POWER CABLE.**

This detailed guide contains important information for the effective and safe use of DRY AGE. In case of any problems, assistance should be sought from an expert technician.

## Troubleshooting

Problem	Possible Cause	Solution
The device is not working.	The device may not be plugged into an electrical outlet.	Check that the unit is plugged in.
	The plug or cable may be damaged.	Replace the plug or cable.
	The fuse that the plug is plugged into may be broken.	Replace the fuse.
	There may be a main power supply failure.	Check the main power supply.
The device is on but the temperature is too high/low.	There may be too much ice on the evaporator.	Defrost the appliance manually.
	The condenser may be clogged with dust.	Clean the condenser.
	The door may not have been closed properly.	Check that the door closes and that the seals are not damaged.
	The ambient temperature may be too high.	Increase ventilation.
	Unsuitable food items are stored in the appliance.	If there is excessively hot food or blockages in the appliance, remove them.
	The device may be overloaded.	Reduce the amount of food stored in your appliance.
The appliance is leaking water.	The device may not be installed on a level surface.	Make sure that you have installed the device on a flat surface.
	The drain outlet may be clogged.	Clean the drain outlet.
	The movement of water towards the drain may be blocked.	Check the drain hose of the device, if there is ice, defrost it. If the blockage continues, call the technical service.
	The water tank may be damaged.	Call technical service.
The device is making unusual noises.	The device may not be installed in a flat or stable location.	Check the installation position and change if necessary.
<b>If the temperature does not remain constant</b>	<b>It could be from the door or the seals.</b>	<b>Make sure the door seals are fully closed and check the fan system.</b>
<b>Low humidity</b>	<b>The humidification chamber may be out of water.</b>	<b>Check the humidification system and add water to the humidification chamber if necessary.</b>
<b>Mold or bad odor</b>	<b>The device may not have been cleaned for a long time.</b>	<b>Clean the inside of the device thoroughly.</b>

**NOTE:** In cabinets with a bar type humidification unit, there is a water tank on the side seen in the rear image and you can add water from there.

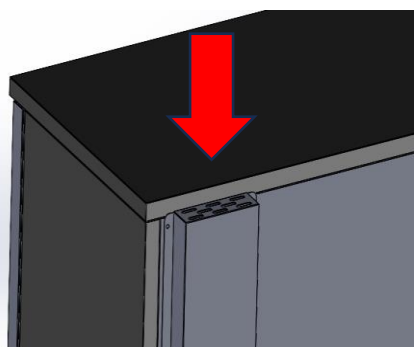

**NOTE:** In upright model cabinets, the humidification chamber has a retractable lid as seen in the image. There is a water filling area on the lid, provide water supply from here.

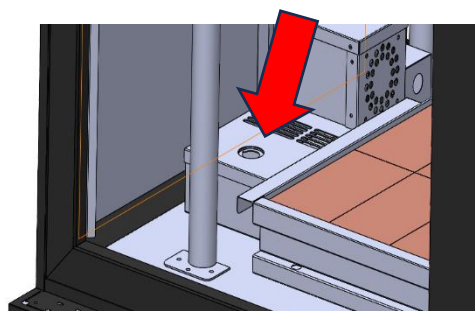

This detailed guide contains important information for the effective and safe use of DRY AGE. In case of any problems, assistance should be sought from an expert technician.

## How to Use the Device:



### 1. How to Use the Screen and Keypad

The following keys are used to control the device:

#### To turn on the device;



You can turn the device on and off by pressing and holding the ON/OFF button for 3 seconds.

### 2. Changing the Set Value

Humidity and temperature set values can be changed as follows.

1. **SET** button once. The temperature set value is displayed. The minimum and maximum values that can be entered are displayed below. It can be set to the desired value within these limits.

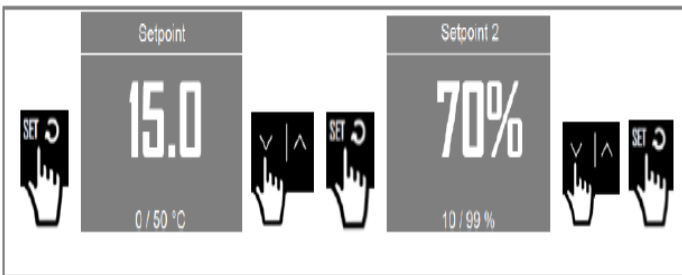

2. The value is set to the desired value with the up and down arrow keys. The Set key is pressed.
3. The humidity value (SET2) is displayed.
4. It is brought to the desired value with the up and down arrow keys. The Set key is pressed and the process is exited.

### Preventing Temperature and Humidity Fluctuations:

Frequent opening and closing of the door can cause instability in temperature and humidity values. Be careful to open the door only when necessary.

To prevent sudden temperature changes, make sure that the products to be placed in the fridge are brought to a temperature of 2-5°C.

### 3. Defrosting Process

Regular defrosting is necessary to increase efficiency and prevent icing in refrigerators. The device offers both automatic and manual defrosting options.

### 3. Manual Defrost; Press



the Up arrow ▲ button. Select “Manual defrost” on the screen that appears and press the “SET” button.

### 4. Alarm Settings and Management:

The device is equipped with an alarm system to detect and report abnormal situations occurring in the cabinet.

#### Door Open Alarm:



If the cabinet door remains open for a long time the device gives a visual and audible alarm.

You can silence the alarm by closing the door.

#### Temperature Deviation Alarm:



If the cabin temperature is measured to be at least 10°C higher or lower than the set temperature value for 120 minutes, it will give an alarm.

This may occur due to the door being left open, hot product being placed suddenly, or a fault in the cooling system.

Once you fix the problem, the alarm will reset automatically.

### 5. Troubleshooting:

#### Door Open Alarm:

You can silence the alarm by closing the door.

**“If the problem persists, contact the authorized service.”**

#### Temperature Deviation Alarm:

Make sure that hot items are not placed in the cupboard or the door is not left open for long periods of time.

After the device cools down, the error message will disappear from the screen. **“If the problem persists, contact the authorized service.”**

**Usage of the Device for SY150, SY250 and DR250;**



**Dixell XR06CH (Temperature Controller) Dixell XT110C (Humidity Controller)**

**1. Changing the Temperature Set Value**

Temperature set values can be changed as follows.



1. **SET** button once. The temperature set value is displayed.
2. The value is set to the desired value with the up and down arrow keys. The Set key is pressed.

**SET** Displays the target set point. It is also the confirm key.

**DEF** Press and hold for 3 seconds to switch to manual defrost.

**UP** Increases the displayed value.

**DOWN** Decreases the displayed value.

**2. Changing the Humidification Set Value**

Humidification set values can be changed as follows.



- 1- Press and hold the SET button for 3 seconds.
- The adjusted set value will appear on the screen.
- Select the desired set value with the up and down arrow keys and press the SET key.
- Wait 10 seconds to return to the main screen.

**Glass Resistance Button**

**1. Function and Purpose of Use,**

The Glass Resistance button controls a heating system designed to prevent fogging or freezing on the glass surfaces of the device. In devices such as industrial refrigerators, it provides the user with a better field of vision by keeping the glass transparent. Especially in sudden temperature differences between cold and hot air, condensation (fogging) may occur on glass surfaces. When the glass resistance is activated, it prevents fogging by creating a slight heat on the glass surface.



**2. Usage;**

Using the Glass Resistance button is very simple: Key On (Green Light On):

The resistor integrated into the glass surface becomes active. Fogging and moisture that may occur on the glass are prevented.

The field of view remains open, allowing products to be seen clearly.

Button Off (Not Illuminated):

The window resistance is disabled.

Energy consumption is reduced and savings are achieved.

Depending on the working environment, fogging may occur on the glass.

**3. Areas of Use;**

This key should be used actively, especially in the following cases:

High Humidity Environments: If glass surfaces frequently condense, it can be kept open at all times.

During Hot-Cold Transitions: If the device is turned on and off very frequently or the ambient temperature is constantly changing, it can be turned on to prevent the glass from instantly fogging.

If such situations do not occur, it is recommended to keep the window resistance off in order to save energy.

**4. Things to Pay Attention to:**

**Avoid Unnecessary Use:**

If the glass heater is kept on continuously, it can consume unnecessary energy. Therefore, it should only be used when necessary.

**Turn Off Before Maintenance and Cleaning:**

When performing maintenance or cleaning of the device, it is important to disconnect the power supply and turn off the glass resistance for safety reasons.

**Check if the Glass Overheats:**

Normally the glass surface will have a slight heat, but if excessive heating is noticed, technical service should be contacted.

In case of malfunction, consult technical service:

If the glass resistance does not work, the key light does not work or excessive moisture accumulates on the glass, technical service should be contacted.

**Maintenance and Repair Instructions for the Efficiency and Safe Operation of the Device;**  
**IN ORDER TO GUARANTEE THE EFFICIENCY AND CORRECT OPERATION OF THE DEVICE, REPAIRS MUST BE COMPLIED WITH THE MANUFACTURER'S INSTRUCTIONS AND PERIODIC SERVICES MUST BE PERFORMED BY PROFESSIONALLY QUALIFIED PERSONNEL. (LEGAL OBLIGATION FOR THE PREVENTION OF WORK ACCIDENTS AND THE INSTALLATION OF ELECTRICAL DEVICES) IT MUST BE IN ACCORDANCE WITH ELECTRICITY SOURCE REGULATIONS. EFFICIENCY IS ENSURED BY FOLLOWING THE FOOD STORAGE INSTRUCTIONS DESCRIBED IN PARAGRAPH 3.2 AND ROUTINE MAINTENANCE DESCRIBED IN PARAGRAPHS 3.4, 3.5 AND 3.6.**

**DR10;**

As seen in the visual picture, the loading should be done in a way that the meat aging process is equal. Internal temperature and Humidity degrees are given below.



**DR10; Internal Temperature: 0/+1 °**  
**DR10 Humidity; 65% - 85%**  
**Gross Volume: DR10-SY-G-HM 630 LT**  
**DR10-G: 680 LT**

**SPD11-217;**

As seen in the visual picture, the loading should be done so that the meat aging process is equal. Internal temperature and Humidity degrees are given below.



**SPD11-217; Internal Temperature: 0/+1 °**  
**SPD11-217; Humidity; 65% - 85%**  
**Gross Volume: SPD11-217 1350 LT**

**DR13;**

As seen in the visual image, loading should be done so that the meat aging process is equal. Internal temperature and Humidity degrees are given below .



**DR13-G; Internal Temperature: 0/+1 °**  
**DR13-G Humidity; %65 - %85**  
**Gross Volume: DR13-G 1300 LT**

**SY6-G-HM:**

As seen in the visual image, loading should be done so that the meat aging process is equal. Internal temperature and Humidity degrees are given below.



**SY6-G-HM; Internal Temperature: 0/+1 °**  
**SY6-G-HM; Humidity; 65% - 85%**  
**Gross Volume: SY6-G-HM 600**

**DR6-G;**

As seen in the visual picture, the loading should be done in a way that the meat aging process is equal. Internal temperature and Humidity degrees are stated below



**DR6-G; Internal Temperature: 0/+1 °**  
**DR6-G; Humidity; 65% - 85%**  
**Gross Volume: DR6-G 600 LT**

**SY13-G-HM;**

As seen in the visual picture, the loading should be done in a way that the meat aging process is equal. Internal temperature and Humidity degrees are stated below.



**SY13-G-HM; Internal Temperature: 0/+1 °**  
**SY13-G-HM; Humidity; %65 - %85**  
**Gross Volume: SY13-G-HM 1300 LT**

**SY150 -G-HM;**

As seen in the visual picture, the loading should be done so that the meat aging process is equal. Internal temperature and Humidification degrees are stated below



**SY150-G-HM; Internal Temperature: 0/+1 °**  
**SY150-G-HM Humidity; 65% - 85%**  
**Gross Volume: SY150-G-HM 103 LT**

**SY250-G-HM;**

As seen in the visual picture, the loading should be done in a way that the meat aging process is equal. Internal temperature and Humidity degrees are stated below



**SY250-G-HM; Internal Temperature: 0/+1 °**  
**SY250-G-HM; Humidity; 65% - 85%**  
**Gross Volume: SY250-G-HM 198 LT**

**DR250-G;**

As seen in the visual picture, loading should be done so that the meat aging process is equal. Internal temperature and Humidification degrees are stated below



**DR250-G; Internal Temperature: 0/+1 °**  
**DR250-G; Humidity; 65% - 85%**  
**Gross Volume: DR250-G**

## THINGS TO BE CHECKED ABOUT ICING

1-Door seals should be checked and it should be ensured that no air is allowed into the cabinet. If the seal is not fully closed, the cabinet will produce ice in the cooling section and on the plastic profile.

2-Door seals should be checked and it should be ensured that no air is allowed into the cabinet. If the seal is not fully closed, the cabinet will produce ice in the cooling section and on the plastic profile.

3-When loading products into the cabinet, the number 1 suction channel and number 2 blowing channels indicated in red should not be covered with products and a gap of at least 15 cm should be left. You can see the sample maximum loading order in the image.



4-The outdoor temperature where the cabinet is located should be a maximum of 38°C - 40°C. At temperatures higher than this, the cooling performance of the cabinet decreases and may cause icing.

5- The products in the refrigerator should be brought to a temperature of 2-5 ° C in advance. When an uncooled product is placed in the refrigerator, frosting occurs in the evaporator due to the moisture from the hot product and this negatively affects cooling.

6-When the refrigerator is defrosted manually, it should remain in defrost for a minimum of 10 minutes and a maximum of 30 minutes. During defrost, the evaporator temperature should reach 18°C.

*To defrost, see "3. Manual Defrost" on page 5.*

7- When the refrigerator is actively used during the day (such as taking out or placing products), in order to clean the frost that forms on the evaporator and if ice forms in the refrigerator over time, the refrigerator should be manually defrosted at the end of each evening service and manually defrosted in the morning before service begins.

8-When new products are to be placed in the refrigerator, the refrigerator should be turned off for long-term loading and then turned back on after the products are placed. In this way, the hot air entering the refrigerator will be reduced. The door should be left open for a maximum of 3 minutes during loading. When the door is left open for more than this, the fans will stop and the compressor will run, causing frost to form in the refrigerator. After the doors are left open for more than 3 minutes, the product should be defrosted manually.

**Frost formation in the refrigerator is generally caused by the user, and if care is taken when using it, there will be no possibility of frost formation.**

This detailed guide contains important information for the effective and safe use of DRY AGE. In case of any problems, assistance should be sought from an expert technician.

If these conditions are checked and no problem is seen and icing still continues;

9- Make sure the door is closed and the seals are intact.

10- Check if the resistances are working, - Check the rod resistance inside the evaporator and the adhesive resistance underneath,



11- Check whether the evaporator fans are working.



**If the icing problem still persists after doing all these, please contact the dealer or technical service to replace the faulty spare part.**

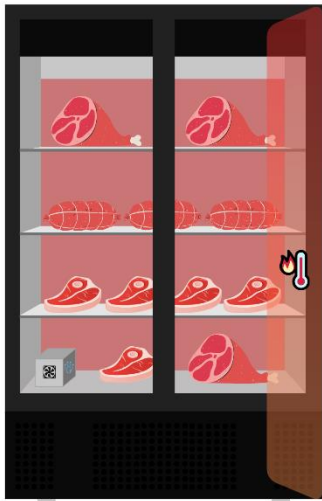

Creating high heat sources around your refrigerator will reduce its efficiency and increase electricity consumption.

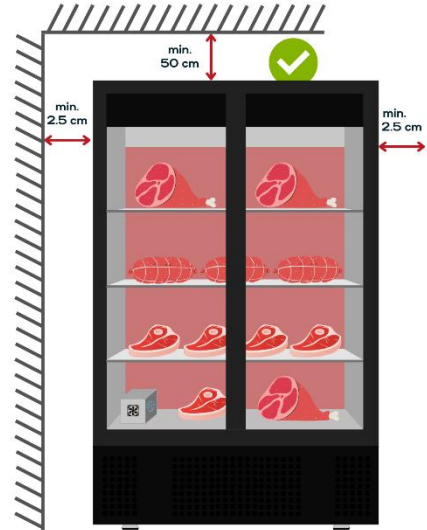

To ensure your refrigerator operates efficiently, make sure the air vents and the top are not obstructed.

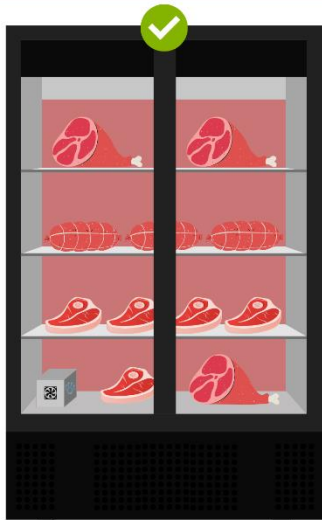

Loading your refrigerator without obstructing airflow will greatly enhance cooling efficiency and extend its lifespan.

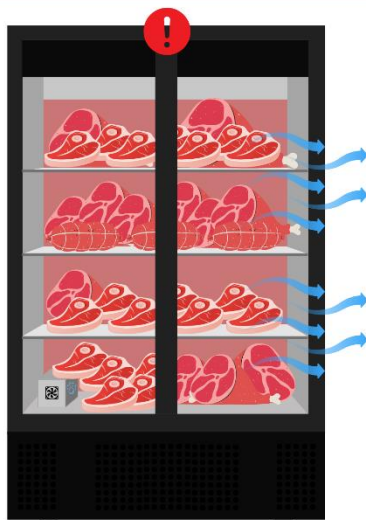

For efficient and energy-saving use, make sure the door is not left open for more than 1 minute.



Cleaning the evaporator every 3 months to remove dust and dirt, while avoiding damage to its delicate metal components, will extend your refrigerator's lifespan and keep its cooling performance like new.

To increase the efficiency of your cabinet at the end of the operation, it is recommended to perform a Manual Defrost daily.



For Manual Defrost, press and hold the (🧊) button until the defrost logo appears.



GGM Gastro International GmbH  
Weinerpark 16  
D-48607 Ochtrup

[www.ggmgastro.com](http://www.ggmgastro.com)      [info@ggmgastro.com](mailto:info@ggmgastro.com)  
+49 2553 7220 0