

EFDJ481 Open Fryer

# **Open Fryer**

## **INSTRUCTION MANUAL**

Read this manual carefully prior to use.  
Technology is subject to change without notice.

# Table Of Contents



The only way to ensure a safe operation is to fully understand the proper installation, operation, and maintenance procedures. The instructions in this manual have been prepared to aid you in learning the proper procedures.

**Notice:** Notice is used to highlight especially important information.

**Caution:** Caution used without the safety alert symbol indicates a potentially hazardous situation which, if not avoided, may result in property damage, minor or moderate injury.

**Warning:** Warning indicates a potentially hazardous situation which, if not avoided, could result in death or serious injury.

**Danger:** Danger indicates an imminently hazardous situation which, if not avoided, could result in death or serious injury.

- Breaker and fuse must conform to the requirement of the fryer.
- Never touch cables or switches with wet hands.
- Never lay cables on ground, hard edge, or sharp metal, if not avoided, could damage the cables or electric shock.
- The fryer should be located with provision for venting into an adequate exhaust hood or ventilation system. This is essential to permit efficient removal of the exhausts and frying steam.
- Do not overload, or place product with extreme moisture content into the fryer. 1.4Kg is the maximum amount of product per time of one fryer. Failure to follow these instructions can result in oil overflowing, which could cause serious burns, personal injury, fire and/or property damage.
- Once spotted cable damage, should replaced with new soft oil proof cable to avoid electric shock.
-  Grounded wire must be connected.
- Before plug power cord, fully check power supply cable whether conform to the requirement of the fryer, failure to follow the requirement, could result in short circuit or fire.
- Only qualified personal be allowed to open electric cabinet.
- Do not use a water jet (pressure sprayer) or sink to clean fryer or component damage could result.
- Do not heat oil exceed 200°C could result in fire or bad taste.
- Fryer must be connected with adequate electric support. Voltage wave limited in 5%. Refer to local electric procedures and regulation.
- If using plug cord, must push in fully tight, failure to follow this, could result in fire.
- Never pull cord plug with wet hands, holding plug only, not cord.
-  Equipotential ground is in the rear of fryer. When several fryers have been set work at same time, equipotential ground must be connected to avoid electrical potential difference.
- Before disconnect or connect, must cut off main power supply.
- Before turn main power supply on, must vision check fryer and connection thoroughly.

- Only qualified personal be allowed to undertake electrical installation and repair.

### Caution

- Never touch heating element, could result in serious burn.
- Avoid rain and humidity.
- Choose a location which will avoid corrosive atmosphere and uneven floor.
- Never turn up-side down the fryer.
- The oil level must always be above the burner tubes when the fry is heating. Filled up oil must match level indicators on the rear of the vat. Failure to follow these instructions could result in a fire and/or damage to the fryer.
- To avoid fire, install the open fryer in a place without combustible materials.
- With repeating frying, the flash-point of the oil is reduced. Discard oil if it shows signs of excessive smoking and foaming.

### Notice:

### Installation

**To ensure operation in convenience manner, must eliminate the conditions below:**

- Uneven or unstable floor.
- Surround with combustible materials.
- Dusty, hot and humid.
- Electrical power support unstable.
- No adequate grounding wire.

### Operation

- This appliance is not intended for use by persons(including children) with reduced physical, sensory or mental capabilities, or lack of experience and knowledge.
- The pot lid is for clean and warm keeping propose. When putting lid back, must make sure of the lid is dry. Any water drop could result in boiling over.
- Move fryer with care, prevent oil splashing. Hot oil splashing could result in serious burn.
- No punching or hammering, when malfunction occurred.
- After cooking, operator hangs baskets on basket rest to drop excess oil of product.
- The high temperature of the oil is limited on 200°C . If the oil temperature rushed to 230°C, control system could automatically cut off electrical support. Let oil cool down to 150°C, push metal reset button to restart the fryer.

### Advise

### Trouble Shooting

- If any malfunction occurred, stop using and cut off electrical, contact local distributors.
- Do not attempt to disassemble or repair the fryer, except maintenance which shows in this instruction.
- If any oil leaking spotted, stop using and contact with local distributors.

## I. Specification

Parameter	Model
	EFDJ481
Power supply	3N~380V/50Hz
Specified power	14.2kw
Temperature range	20-200°C
Capacity	26L
Measurement	450*860*1130mm
Net weight	80Kg

## Caution

1. This fryer is designed to work with gas pressure  $\leq 2.8\text{KPa}$  and gas flow  $0.6\text{m}^3/\text{h}$ .
2. Middle or high pressure valves are forbidden!
3. Do not connect or disconnect gas hose, pipe or valve if the place exists flame or fire!
4. Upon initial installation, and after moving the fryer, the piping and fittings should be checked for gas leak.
5. According to instruction to check electrical power support connection again, make sure the fryer be connected properly.
6. The electrical support must conform with the requirement which marked on the nameplate. Three phases four wires connection, do not mix up the neuter wire.
7. The oil level must always be above the minimum line and under maximum line which marked on the rear of vat.
8. Failure to follow this instruction, could result in personal injury and/or fire.

## II. Open Fryer series Control Panel Indication



## III. Control Panel Illustration

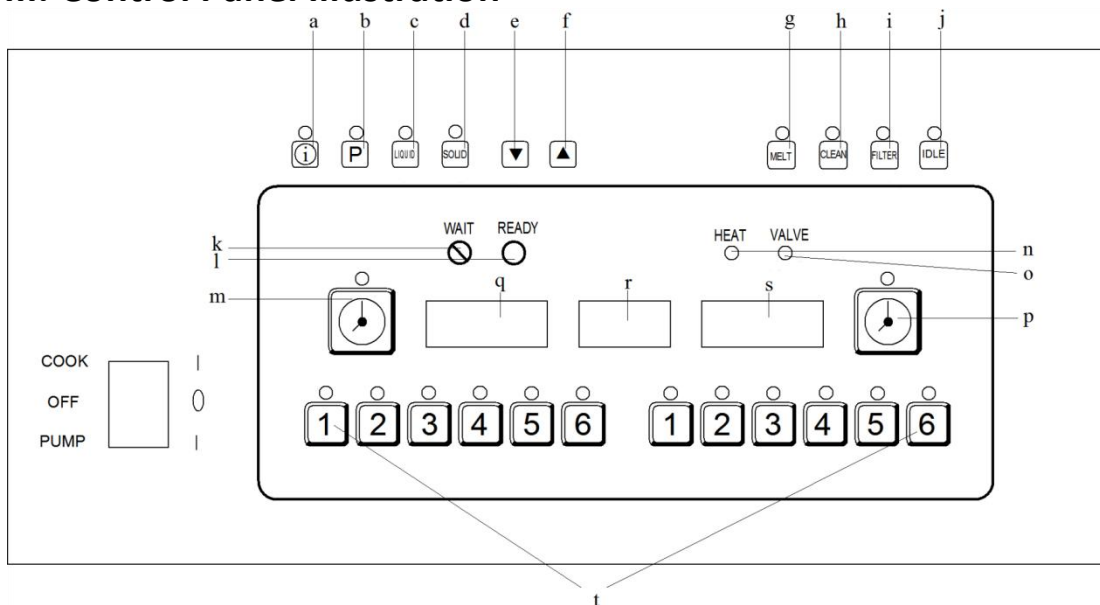

## IV. Operation

### 1. Description of button

- a. Information :** Press once to view oil set-point temperature, press twice to view set-time, and three times to view remind set-time, four times to view filtration times.
- b. Program :** press once to set oil temperature, press twice to set cooking time, and three times to set remind time(count down), four times to set filtration option. Press Plus or Minus button to change parameter.
- c. Liquid :** Press button then LED will be lit, indicate liquid oil picked.
- d. Shortening :** Press button then LED will be lit, indicate shortening picked.
- e. Minus or move down**

**f. Plus or move up**

**g. Melt mode:** Press button then LED will be lit, indicate to start melt shortening; Press button again then LED will be went out, indicate to exit melt mode.

**h. Clean:** Press button then LED will be lit, indicate to start clean mode, meanwhile press **P** button to set duration and temperature of clean mode; Press button again then LED will be went out, indicate to exit clean mode.

**i. Filtration :** Press button then LED will be lit, indicate to start filtration mode, meanwhile press **P** button to set oil temperature during filtration mode; Press button again then LED will be went out, indicate to exit filtration mode.

**j. Idle mode:** Press button then LED will be lit, indicate to start idle mode, meanwhile press **P** button to set oil temperature during idle mode; Press button again then LED will be went out, indicate to exit idle mode.

**k. Wait:** LED lit indicate oil temperature under set-point.

**l. Ready:** LED lit indicate oil temperature reach set-point.

**m.Timer Left Vat:** Press button to start/stop left vat cooking time count down.

**n. Heating:** LED will be lit when heating system is on, if LED went out indicate that heating system is off.

**o. Valve Opening:** LED lit indicate valve opened, LED went out indicate valve closed.

**p. Timer Right Vat:** Press button to start/stop right vat cooking time count down.

**q. Display:** Indicate status of left vat.

**r. Display:** Indicate status of oil temperature, switch.

**s. Display:** Indicate status of right vat.

**t. Product Button 1~6:** Each product button indicates a cooking cycle which user set.

## **2. Parameter Display And Programming**

**Power Off:** r shows "OFF"

**Valve Opened:** q shows "open", o lights up.

**Power On:** Display shows "on-C/F-x.x" (C indicates Celsius temperature scale, X.X indicate Version No), and alarm sounds.

**Melt Shortening:** g lit up, Liquid c lit up, Solid d lit up. Three seconds after power on, fryer automatically starts melt mode. Press g button to exit melt mode. Oil temperature reaches 110°C then control automatically exits the melt mode.

**Liquid:** Heating rate be held on 50%.

**Shortening:** Heating rate be held on 10%, until temperature reaches 80°C, then automatically raise heating rate up to 50%.

**Clean:** Clean time counts down in minutes, END indicates Clean work finished.

Temperature Range: 40~90°C (104~194F)

Minutes Range: 0~59:59

**Idle:** Press j button to start Idle Mode. The oil temperature during Idle Mode could be set: 90~190°C (194~374F)

**Filtration:** After a certain number of cook cycles, the control periodically shows "filter now?". Operator must open drainage valve to start filtration. When valve opened, o will be lit up. q shows "open". Drainage valve must be opened no less than 25 seconds, otherwise fryer could not back to normal operation. The temperature range: 120~190°C (248~374F)

**Cook:** After input temperature of cook, time of cook and filtration value, the fryer ready to cook food.

Cook time range: 0~59:59 (mm:ss)  
 Cook temperature range: 90~190°C (194~374F)  
 Filtration option: 0 or 1, 0 equals discard, 1 equals count.

### 3. Alarm

End of a time cycle: Display shows “End”  
 Time reminder: Time flashes on the display.  
 Filtering: The oil temperature reaches set-point, display shows “FIL”.  
 Actual temperature beyond 210°C: Display shows “Hot”.  
 Thermal sensor upscale/downscale burnout: Display shows “Err”

### 4. Wiring diagram

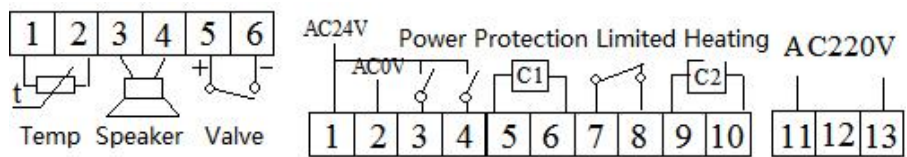

### 5. Advanced Programming Code (Attention: Any wrong input could cause fryer malfunction)

Turn off fryer, then press and hold **P** to enter code “0005”, press **P** to confirm and start advanced programming.

- I01 (-99~99) Temperature Calibration, Initial Value:0
- I02 (0~99) Temperature Ratio, Initial Value:15
- I03 (0~99) Temperature Ratio During Cooking, Initial Value:2
- I04 (0~9.9) Temperature Tolerance Value (downward), Initial Value:2.0
- I05 (0~1) Temperature Operation, 0 equals ratio control, 1 equals PID, Initial Value:0
- I06 (0~99) Filtration times to Lock-down, 0 equals Discard, Initial Value:10
- I07 (0~1) Temperature Format, 0: Celsius, 1: Fahrenheit, Initial Value:0

## V. Gas Fryer Work Method And Operation

### 1、 Gas Fryer Burning System

Gas fry adapts LPG or LNG, be equipped with unique 4in1(lasting flame, thermocouple, electric ignition and venting adjustment) gas control valve, temperature control and gas electron magnetic valve. Combined electric ignition, thermostatic control, flame-out lock-down device and heat control are ensuring a safe and reliable burning system.

### 2、 Work Method

Push and turn ignition switch, a high voltage electron current will be released to the tip of ignition, generating a tiny spark between the gap of two ignition tips, this spark will light up a flame which called lasting flame. The lasting flame heat thermocouple, control system automatically open gas valve until thermocouple

reaches set-point, lasting flame will light up gas to heat the fryer. The control system of fryer coordinates with temperature vary to automatically control gas valve open to light up heating burner or cut off gas supply to avoid over heated, repeating the cycles to achieve evenly oil temperature.

For prevent gas leakage, lasting flame device is an important precaution. Lasting flame is essential element to keep burning system work safely. If lasting flame goes out, the thermocouple immediately release a signal to cut off gas supply.

### 3、 Gas Ignition Operation

After ensured a safety workplace, then connect gas hose. Using soap water to check gas leakage, make sure of no leakage. Open gas valve, wait a second then push switch and turn anticlockwise(remaining two seconds when switch turns to middle).

(See Picture 1-4)

Hearing “katakata”, it means that burning system is igniting and lasting flame should be lit up. Pushing the switch for a few seconds ensure lasting flame goes well, let thermocouple of lasting flame keep heating, it makes sure of lasting flame working well(If it does not light up at first, then could try several times. After several times attempt, ignition fail to light up, probably malfunction of gas supply or ignition). Rotary switch anticlockwise to adjust the size of burning system flame. ( See above Pictures )

**Notice: During ignition operation, drainage valve must be closed.**

### 4、 Cooking

While heat system is working, oil temperature raises steadily. When READY button lit up, the fryer is in cooking condition. According to each product requirement to set cook cycle, two baskets place in a vat, two cook cycles can be set in meanwhile via split two group product buttons.

**Warning: Using gas as heating source, the workplace of fryer must be equipped with venting hood system or ventilation, sucking exhaust and frying steam to outside. Adequate fresh air prevent personal gas poisoning.**

## VI. Component Illustration

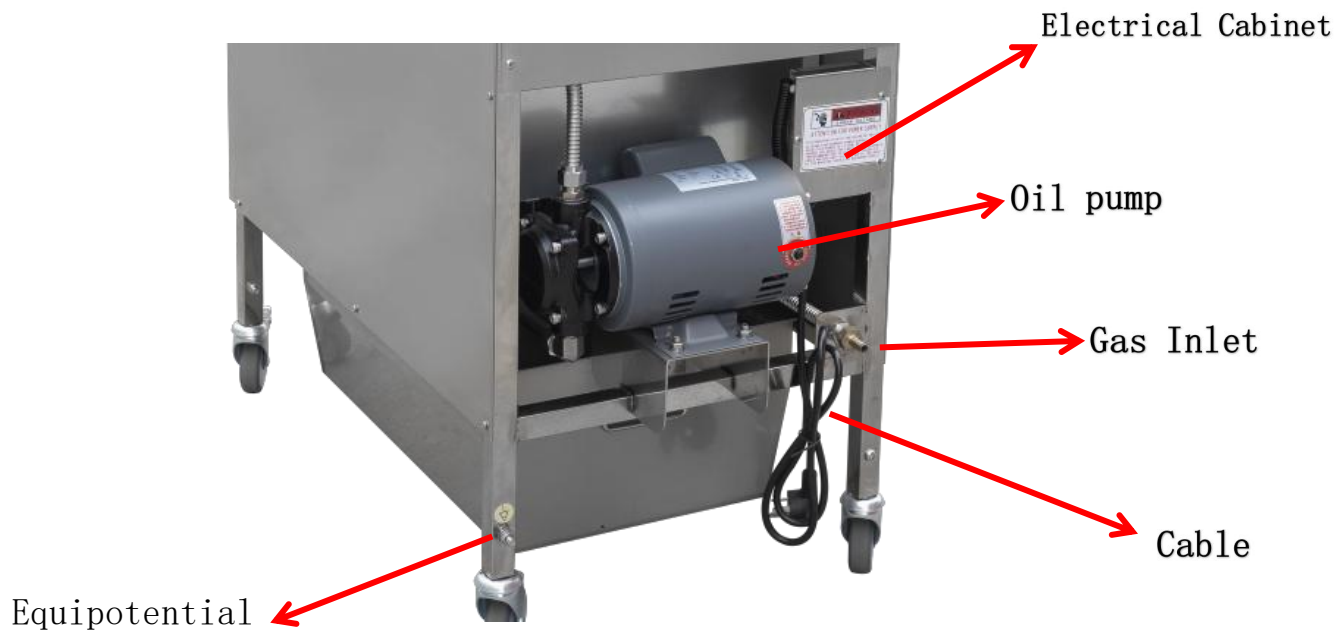

## VII. Gas Fryer Circuit Diagram

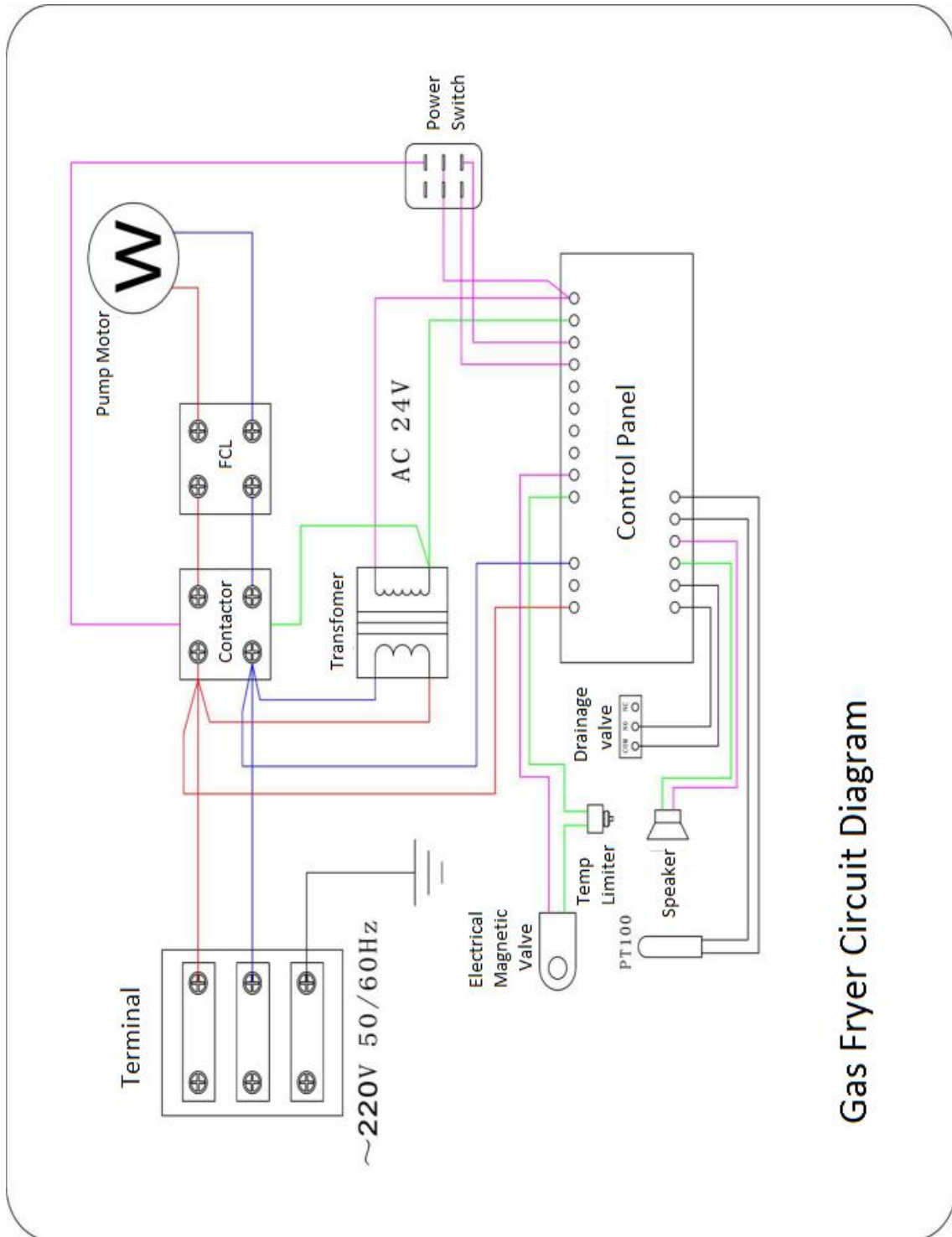

Gas Fryer Circuit Diagram

## VIII. Electrical Fryer Component Illustration

HEATER SKETCH DIAGRAM

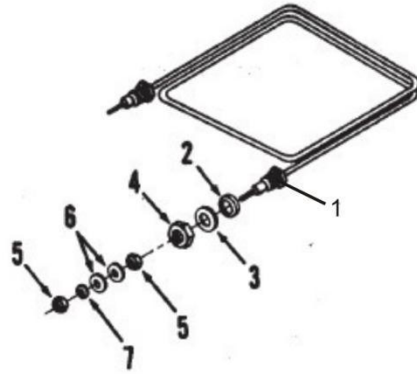

1. SCREW FOR HEATER
2. PTFE PAD FOR SEALING
3. PAD
4. FASTENING SCREW
5. TERMINAL NUT
6. PAD
7. SPRING PAD

CHART12

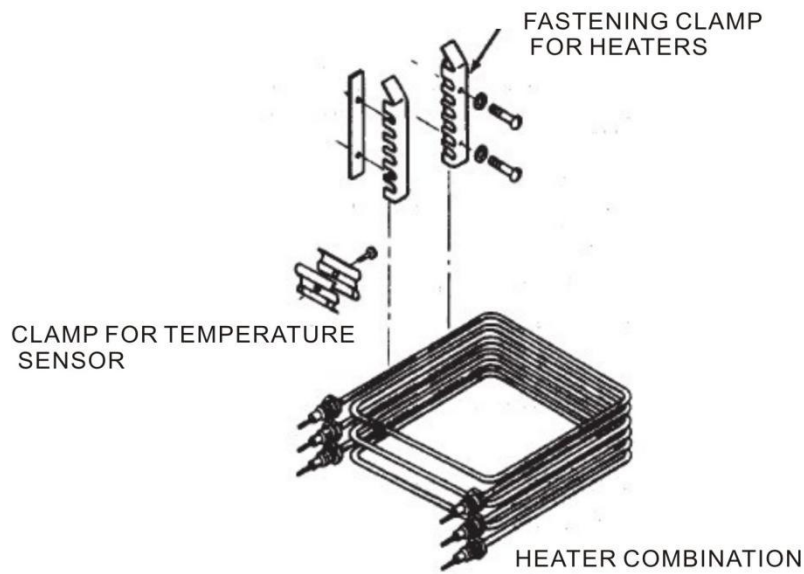
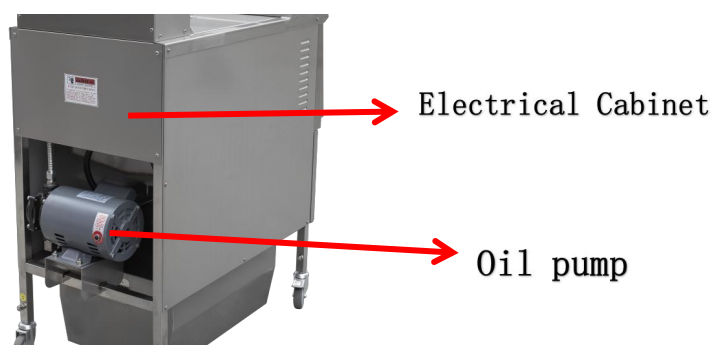
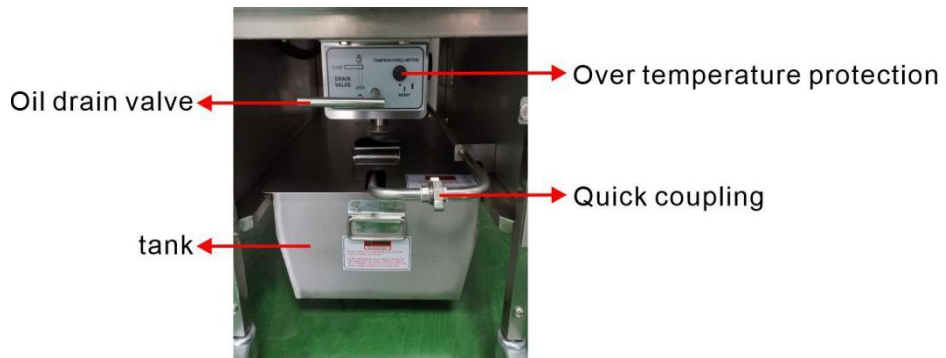
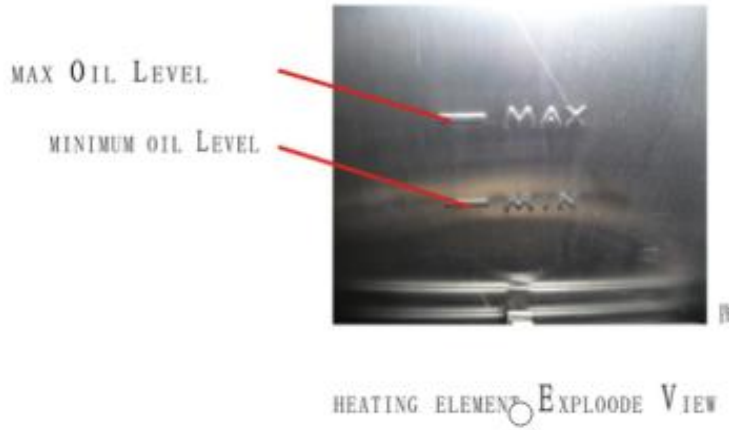

CHART13

WHEN YOU ASSEMBLE THE HEATERS, MAKE SURE THE FIXING OF CLAMP. IT IS MORE SECURITY AND STEADY USING OF HEATING COMBINATION.

## IX. Electrical Fryer Component Illustration



## X.External structure diagram



# XI. Electrical Fryer Circuit Diagram

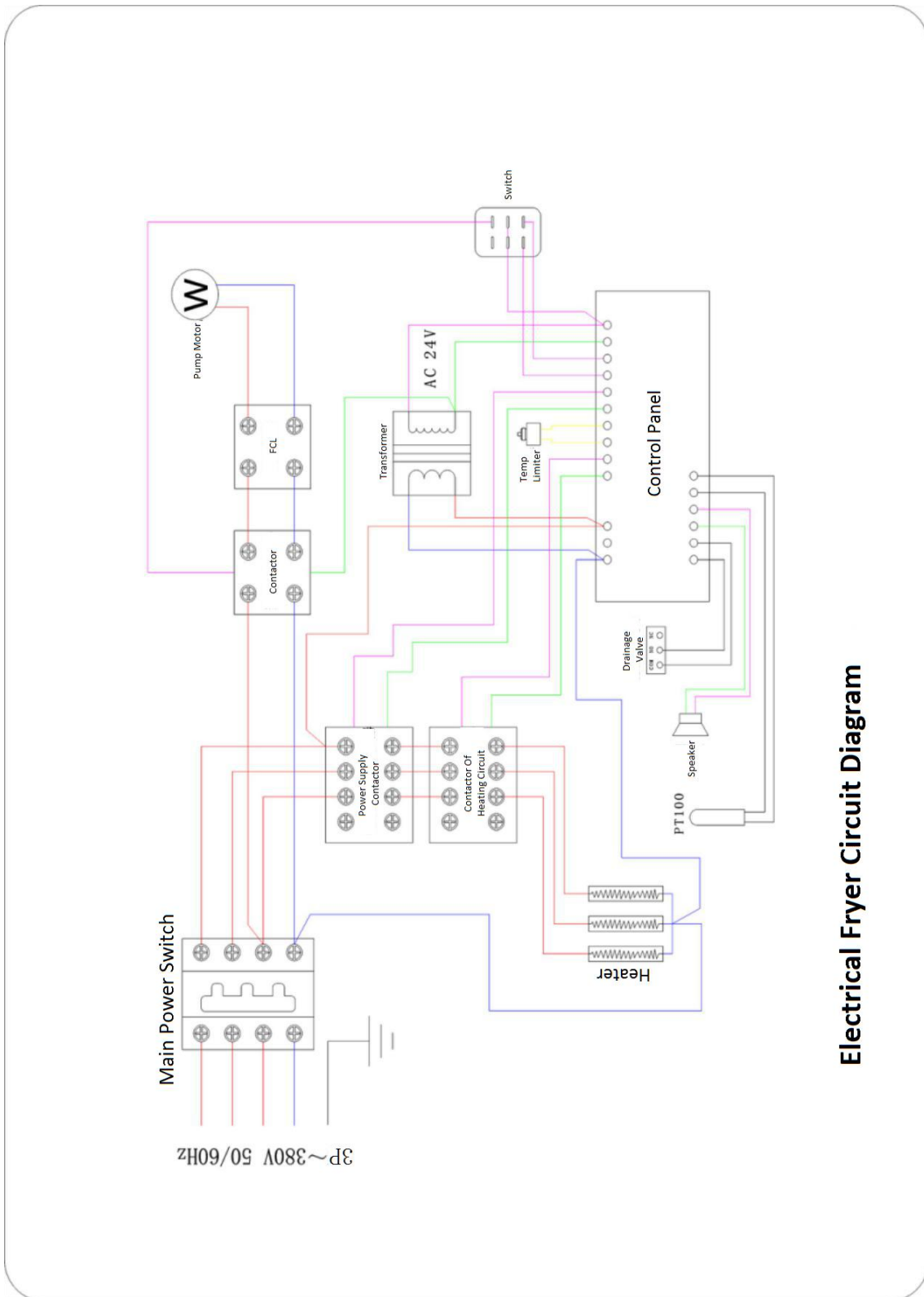

**Electrical Fryer Circuit Diagram**



GGM Gastro International GmbH  
Weinerpark 16  
D-48607 Ochtrup

[www.ggmgastro.com](http://www.ggmgastro.com)      [info@ggmgastro.com](mailto:info@ggmgastro.com)  
+49 2553 7220 0