

**To protect your interests, please read the instruction manual carefully before use the product, and please keep this manual and warranty card**

## **Hard ice cream machine series**

**User manual warranty card**



# Contents

- 1: Application
- 2: The Characteristics
- 3: Hard Ice Cream Machine Cleaning Loading And Unloading
- 4: The Technical Parameters
- 5: The Conditions Of Use
- 6: Installation and Operating Instructions
- 7: Hard ice cream machine common faults and processing schedule
- 8: Making hard ice cream
- 9: Maintenance and upkeep
- 10: Attention Matters
- 11: Electrical schematic diagram
- 12: Repair Processing

## 1:Application

Using the product low input, high return.Choose the products will be your wise choice.This series of products applicable to the hotel, the guesthouse, cold stores, Internet cafes, dance halls, cafes, resorts and other places of entertainment

## 2: The Characteristics

Ice cream machine adopts imported stainless steel plate, special digital board computer control, digital display, the world famous brand compressor, has stable operation, large output, low power consumption, etc.,.

## 3: Hard Ice Cream Machine Cleaning Loading And Unloading

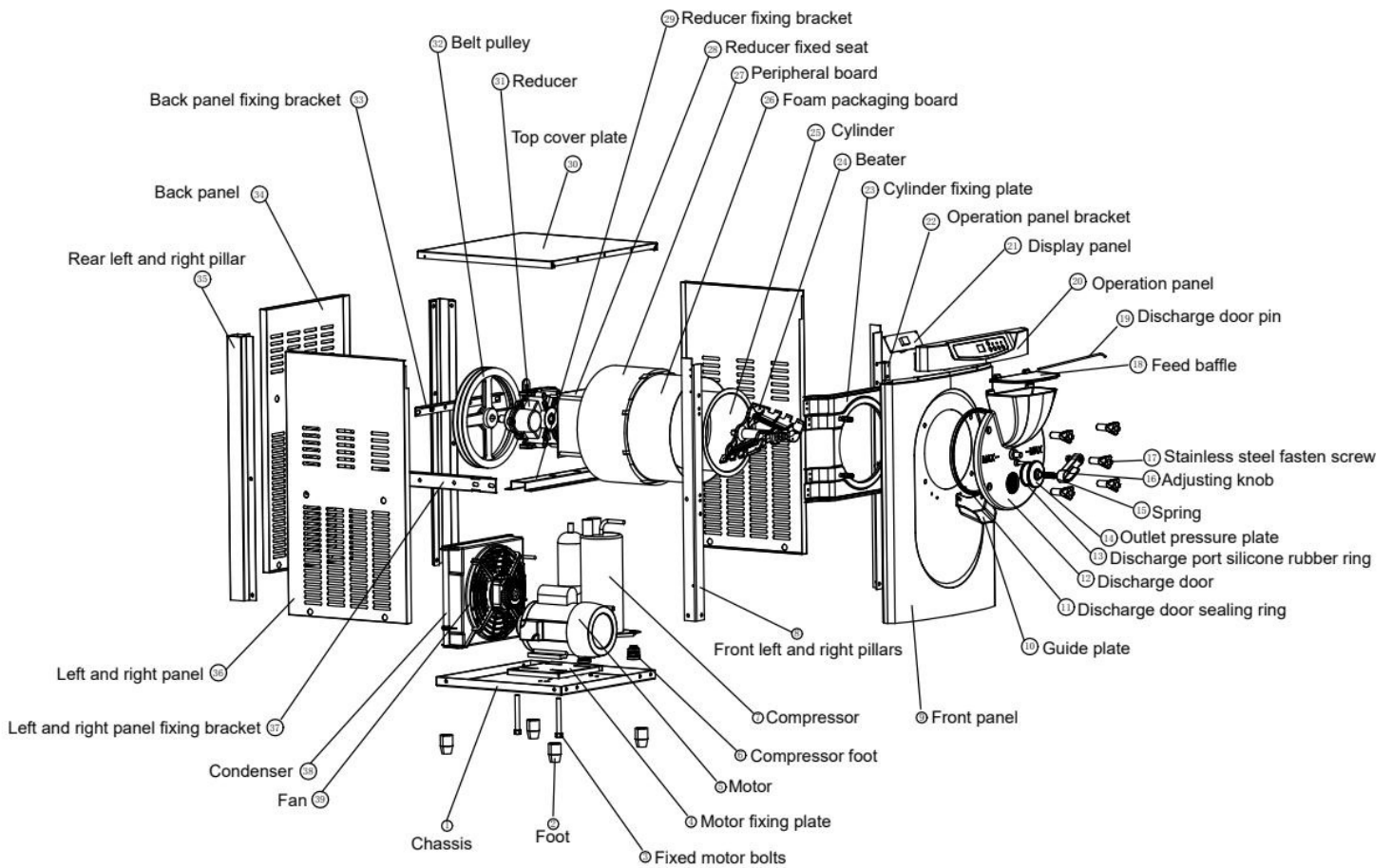

## 5:The Conditions Of Use

Hard ice cream machine as a kind of commercial refrigeration equipment, it can work in the following conditions:

Ambient temperature: 10~ 40 °C      feed temperature: 2 ~ 35 °C  
Power supply voltage:220~240v      range: 50 + 1 HZ

Note: the environment temperature, the feed temperature will directly influence the refrigerating capacity and output.

## 6:Installation and Operating Instruction

A):the installation:

Before the installation has a detailed reading machine side panel on the yellow "special attention", attention please strictly in accordance with the requirements of the installation operation.

1, place the conditions:

A, the machine should be placed A smooth level, please lock the front wheel brake after steadier.

B, the machine should be placed where the heat dissipation, good ventilation conditions, and avoid heat and direct sunlight, exhaust of the machine or other similar surface and wall obstructions should be more than 1 m distance between, other side should be similar to walls or other obstacles should be interval distance of 0.3 meters.

C,the machine should not be placed in the dust,keep sanitation clean

2, power supply wiring requirements:

A, please ensure that the power socket must be equipped with effective grounding line.

B, please make sure that the machine's power supply lines equipped with short circuit protection and leakage protection device

C, please make sure that the use of table top ice cream machine power supply cord shall not be less than 2.5 square millimeter of copper core power. Floor standing ice cream machine power supply cord shall not be less than 4.0 square millimeter of copper core power.When the power cord through the hours,

can make the load is too large, leading to a less voltage, affect the machine work, and even damage. Machine working voltage range is: 220 v to 230 v, 380 v model for 365-400 - v)  
 (attachment: operation panel)

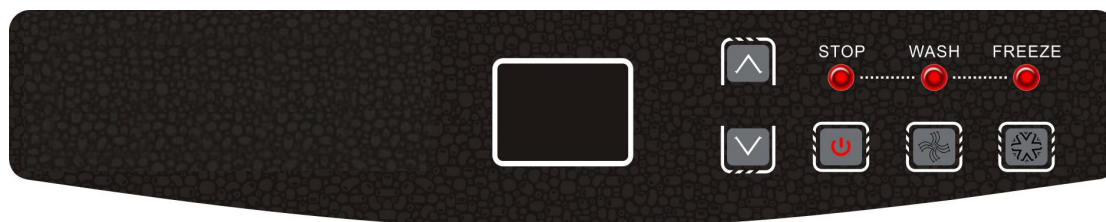

2), the operating instructions

This machine adopts the set the cooling time, control of ice cream slurry forming hardness, has the motor overload protection function, the operation is simple and convenient. Plugged in, the machine into standby mode the screen shows "00"

Standby mode, press cleaning, cleaning indicator, mixing cleaning system began to work, to the material (water cleaning, clean a minute later from the discharging port to discharge water, rinsed three times or more in accordance with the above program.

B, refrigeration key:

Standby mode, press the key of refrigeration, refrigeration indicator, mixing refrigeration system began to work, the digital tube twinkle display set by time, after 5 seconds, compressor, refrigeration also need digital tube display the current time.

C, the stop button

Press "stop", the machine in the cleaning process and the cooling process, have to stop working, and enter the standby mode,

D, up, down keys

Long press "up" or "descending key" 5 seconds, the digital tube twinkle show the current setting of cooling time, the state point move "up key" or "downward" refrigeration time parameter can be modified.

## 7:BQ series hard ice cream machine common faults and processing schedule

| The phenomenon        | Possible reasons                 | Processing methods                                 |
|-----------------------|----------------------------------|--|
| Machine doesn't start | Power line disconnect            | Check the power supply and a prison                |
|                       | Circuit breakers to disconnect   | Such as circuit breaker manual reset after restart |
|                       | Protection circuit does not work | Restart the machine after troubleshooting          |
| Clean mode does not   | Attachment loose                 | Check the attachment and pick up                   |

|                                  |   |  |
|----------------------------------|---|--|
| work                             |   |  |
|                                  | Mix beater is bad                       | Repair or replace the motor  |
| Automatic mode does not work     | Function switch wire loose              | Check and pick up good connection  |
|                                  | Control panel is bad                    | Replace the control board  |
| Compressor is not running        | Low voltage                             | Solve the problems of voltage  |
|                                  | Contactors bad                          | Change the contactor   |
|                                  | Control board has broken                | Change the control board   |
|                                  | Compressor overload protection tripping | Find and solve the cause   |
|                                  | Compressor is bad                       | Replace the compressor   |
| No refrigeration                 | Refrigerant leakage                     | Find funnelled after repair,filling refrigerant                          |
|                                  | Fan does not run                        | Repair or replace the fan  |
|                                  | Fan capacitor bad                       | Replace the fan capacitor  |
| Ice cream too soft               | Ratio of slurry is wrong                | Make the qualified slurry  |
|                                  | Set the cooling time is too short       | Adjust the ice making time   |
| Ice cream too hard               | Ration of slurry is wrong               | Make the qualified slurry  |
|                                  | Set the cooling time is too long        | Adjust the cooling time  |
| Leakage of material              | Discharge hole leakage material         | Install well discharge or replace the seal ring                          |
|                                  | Discharge door leakage                  | Check the discharge seal ring assemble is reasonable                     |
|                                  | In the back seat leakage material       | Check the seal ring damaged or not,replace new bell ring                 |
| The whole machine noise          | The ground is not flat                  | Demand placed on a level surface   |
|                                  | Deformation of the chassis              | Correction of the chassis  |
|                                  | Screw has loose                         | Check and screw the screws   |
|                                  | Install uneven coaming                  | Increase the foam,plastic  |
| Automatic stop                   | Low voltage                             | Voltage regulator or replace the power cord                              |
|                                  | Sensor is bad                           | Replace the sensor   |
| Mixing motor noise               | Low voltage or unstable                 | Check the voltage,into the wire minimum 2.5mm,not less than 198V voltage |
|                                  | Fastening screw                         | Tighten the screw fixation   |
| Shape change is slow             | The condenser is dirty                  | Clean the condenser  |
|                                  | Poor cooling machine                    | To ensure the machine ventilation  |
|                                  | Coolant leakage                         | Find out and fill out coolant  |
| "E2"、"EF"speed bottom to protect | Slurry is too hard                      | Adjust the cooling time  |

## 8: Making hard ice cream

1) entered the modulation good hard ice cream slurry from plastic material in cylinder inlet pour into ice cream machine, pay attention to size not agglomerate.

(2) set up cooling time, press the refrigeration key to start the machine, enter the working mode automatically, can also according to the first wash key, then press automatic (clean the machine work pass don't time is too long can be  $> < 1$  minute).

(3) the work process, the digital display the current refrigeration process need time, when set to hardness machine automatic stop.

(4) use ice cream: with VAT on discharging mouth below first, and then remove the plastic head discharging pressure plate, then press the refrigeration, can make ice cream, put back after extrusion head out of the plastic clamp.

## 9: Maintenance and upkeep

A, refrigeration cylinder cleaning.

To ensure the health of ice cream consumers, improve the service life of machine parts, you must to a refrigeration cylinder cleaning every day.

(1) according to the cleaning keys, all material slurry in cylinder, press the stop key.

(2) the right amount add detergent with warm water, add it into the tank, filled up to refrigeration cylinder material level.

(3) press washing mixing about five minutes, drain cleaning fluid.

(4) clean with clear water 3 to 5 times, downtime.

(5) turn off the power supply, unpick and wash all the parts.

Such as stop using for a long time, when to use, will turn off the power supply, disassemble the parts is as follows:

A, wrung out plastic nail head side four self-contained, remove the plastic head component;

B, in turn down from the plastic head screw, discharge pressure plate, sealing ring;

C, drawn from the refrigeration cylinder mixer, remove the sealing ring;

D, cleaning and disinfection removed all of the parts, if there is any damage, please change in time;

E, according to the reverse steps will removed parts installed.

B, the fuselage cleaning

By the consumers need is beautiful, clean machine, please feel free to keep the body appearance clean, you can use warm towel dry body, polishing the clear stain, not directly with water washing machine operation panel and internal components, to avoid electrical failure.

C, clean the condenser

Work for a period of time the condenser will be sticky dust heat, cooling effect will be worse (ice cream production performance is: the same time or hard molded), please must once every three months to clean (if using the environment is bad, please wash once a month), had better ask professional cleaning cleaning, turn off the power before cleaning, be careful not to damage the condenser fin.

D, machine after long time, mixing system drive belt may be stretched, need to adjust, had better ask

professional adjustment change, adjust the belt must stop before the power outage, belt to adjust the consistence.

## 10: Attention Matters

- 1, this machine is not ready to physically weak, slow response or people with mental disorders (including children) to use, unless the security responsibility to its staff or with the help of the guidance of safe use;
- 2, children should be supervision, to ensure that they do not play the machine;
- 3, warning: keep the ventilation, shell or embedded in the structure of the machine, should maintain once every three months to clean up the obstacles, best professional cleaners cleaning, please pay attention to turn off the power when cleaning;
- 4, and shall not damage the cooling pipe;
- 5, if the power cord is damaged, to avoid danger, must by the manufacturer, its maintenance department or similar division of professional personnel change;
- 6, empty machine (no water inside the cylinder), under the condition of rotating machine shall not be more than 2 minutes;

## 11: Electrical schematic diagram

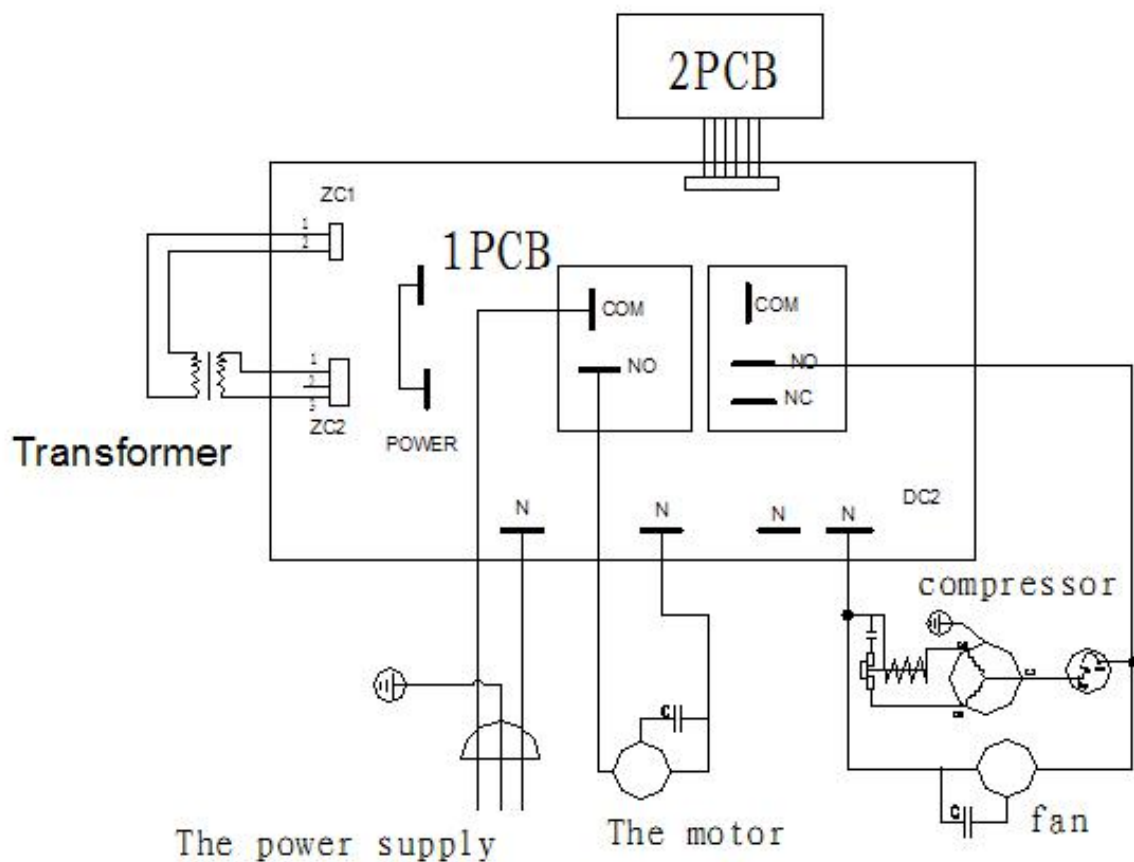

## 12:Repair Processing

The failure for general common failure, you can according to the following table of treatment method, the complex fault, please get professional maintenance staff, don't be hasty, so as not to bring you unnecessary loss.

Equipment maintenance service warranty card

| Sale information   | Users                     |
|--|---------------------------|
| Agency:  | User name:                |
| Contacts:  | Equipment model:          |
| Tel/Fax:   | Purchase date:            |
| Mobile phone:  | User contact information: |
| User requirements: 1, please keep and carefully read the card as soon as possible.   |                           |
| 2, the equipment from the date of purchase you enjoy 12 months free maintenance services.  |                           |
| 3, it is strictly prohibited to change the power phase, to prevent serious equipment failure   |                           |
| 4, please check the power supply, ensure the reliable connection of the grounding line and prevent lack of phase or voltage is too high and too low. |                           |
| 6, please keep the exterior clean, ensure good environment, and regularly check the running status of equipment.                                     |                           |
| 7, the following actions occur will cancel service guarantee:  |                           |
| A, improper use, improper storage transportation environment temperature is too high or too low, exposed to the damp environment.                    |                           |
| B, unauthorized modification, repair misuse, abuse and error adjustment.   |                           |
| 8, equipment abnormal happens, please immediately inform equipment suppliers will be abnormal situation or pits                                      |                           |

|  |                        |                |
|--|------------------------|----------------|
| Equipment maintenance service warranty card(corp)  |                        |                |
| User name:   | Tel:                   | Product model: |
| Address:   |                        |                |
| Factory number :                                   | Purchase date:         |                |
| Date:  | maintenance signature: |                |
| The cause of the problems and the test of results: |                        |                |



GGM Gastro International GmbH  
Weinerpark 16  
D-48607 Ochtrup

[www.ggmgastro.com](http://www.ggmgastro.com)      [info@ggmgastro.com](mailto:info@ggmgastro.com)  
+49 2553 7220 0