

USER MANUAL

ADR-C1-4G / DRAT4E / ADR-C1-5G / DRAT5E

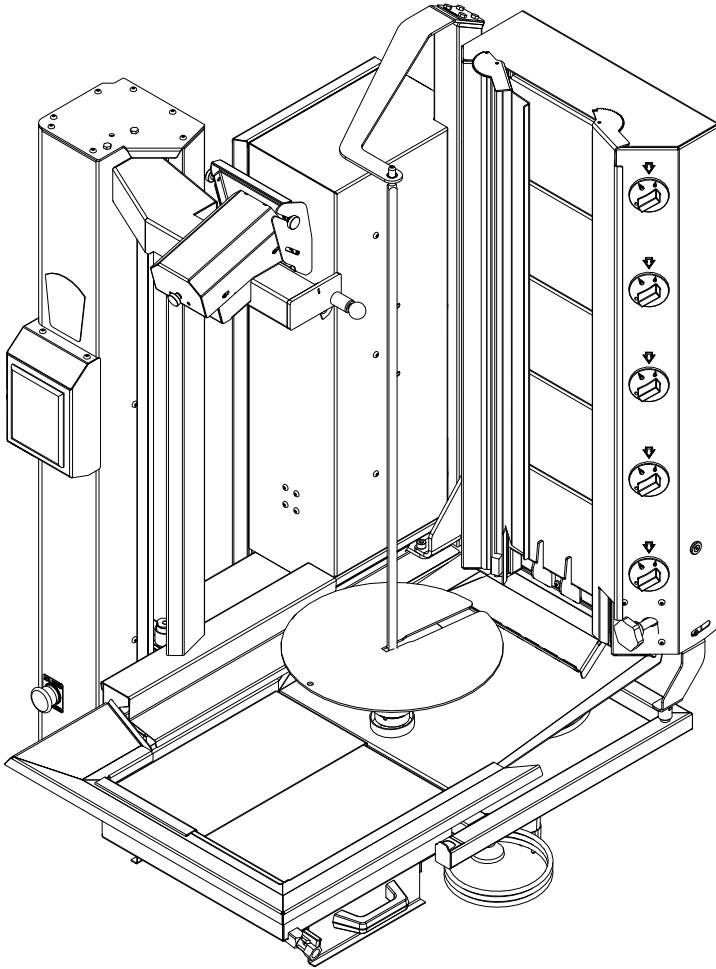

CE

Dear Customers,

Thank you very much for your confidence in our product by purchasing our ADR Compact Series Doner Robot. We want to justify your trust. You have purchased a powerful and reliable Doner Robot machine. If problems still arise: Our customer service is always there to help. Before operating the Doner Robot machine, please read the operating manual thoroughly and observe the instructions. The user manual provides detailed information on operation and provides invaluable information on control, maintenance and inspections. As you know, your warranty applications will not be accepted for damages resulting from incorrect or improper use.

Note: Please enter the type, serial number and year of production of the Doner Robot machine here. You can read this information on the type plate or on the chassis. Always provide this information when ordering spare parts, special retrofit devices or if you have problems.

Item Type

Serial No

Production Year / Purchased Date

Technical developments

We strive to develop our products rapidly and technologically. We reserve the right to apply all improvements and changes we require to our products without prior notice, without transferring them to the machines we have previously sold. If you have different questions, we will gladly answer them.

Regards.

CONTENTS

1. DEFINITIONS

- 1.1. Certifications
- 1.2. CE Mark and EC Declaration of Conformity
- 1.3. Safety rules
- 1.4. Meaning of Warning Labels and Shapes
- 1.5. Product Tag
- 1.6. User Reminders
- 1.7. Abbreviations

2. CARRYING

- 2.1. Installation, Download, Placement
- 2.2. Considerations When Receiving
- 2.3. Working
- 2.4. Safety Precautions

3. ROBOT FEATURES & BASIC INFORMATION

- 3.1. Doner Robot Description Features
- 3.2. Technical Data
- 3.3. Robot Overview and Information

4. PREPARATION OF ASSEMBLY

- 4.1. Demounted Accessories Included in the Package
- 4.2. Product Consumables Spare Parts List
- 4.3. Installation and Operating Recommendations
- 4.4. Doner Robot Assembly

5. OPERATION AND USE OF THE PRODUCT

- 5.1. Cooker Bottom Tray Installation
- 5.2. Tray and Bainmarie Detail Assembly
- 5.3. Feeling Stick Assembly and Knife Sharpening Settings
- 5.4. Skewer Assembly
- 5.5. Oil Shield Assemblies
- 5.6. Cooker Wings Assemblies and Slope Adjustment
- 5.7. Mirror Mount and Skewer Rotation Manual Mode Receive Adjustment
- 5.8. Preparation for Start-Up

INDEX

6. CONTROL AND KEYPAD USE

- 6.1. Definitions
- 6.2. Start and Waiting Positions
- 6.3. Sharpening Functions Settings
- 6.4. Cooking and Rotation Settings
- 6.5. Rotation Speed, Language and Reset Settings
- 6.6. Advanced Settings and Rotating Gauge & Inclination Angles
- 6.7. Blade Cutter Arm Speed Settings and Test Frequencies
- 6.8. Cutting, Beam and Print Thickness Settings

7. ELECTRICAL INFORMATION

- 7.1. Terms, Symbols, Definitions
- 7.2. Network Connections
- 7.3. Connecting the Power Supply UPS
- 7.4. Emergency Stop Button
- 7.5. Use of Robot in Power Failure
- 7.6. Use of Manual Robot in case of Electrical & Electronic Failure

8. MAINTENANCE AND CLEANING ISSUES

- 8.1. Daily Cleaning of the Robot
- 8.2. Periodic Maintenance

9. PROBLEM SOLVING

- 9.1. Possible Faults and Solutions
- 9.2. Warranty and Terms
- 9.3. Warranty Certificate
- 9.4. Authorized Service List

10. ADDITIONAL

- 10.1. Circuit Diagrams
- 10.2. Robot and Accessories Instructions for Use

11. EXPLODED ASSEMBLY AND PARTS LIST

- 11.1 Part List Product Coding Selection Table
- 11.2 Exploded Pictures of Parts and Assembly

1. Description
1.1. Certificates

1. Description

1.2 CE Mark and EC Declaration of Conformity

CE / EC DECLARATION OF CONFORMITY

Gas Burning Devices Directive:	GAR	2016 / 426 / AB - Modül: B+D
Machinery Directive:	MD	2006 / 42 / EC
Electromagnetic Compatibility Directive:	EMC	2014 / 30 / EU
Low Voltage Directive	LVD	2014 / 35 / EU

4- CERTIFICATES FOR EC TYPE INSPECTION, DESIGN, CONFORMITY CERTIFICATE:

CERTIGAZ SAS

62 rue de Courcelles, 75008 Paris / Fransa
Onaylanmış Kuruluş No: CE1312
Pin No: 1312BU5388

CONCEPT TEST VE TEKNOLOJİ MERKEZİ

Köşklü Çeşme Mahallesi 577 Sokak No: 17
PK: 41400 Gebze / Kocaeli / Türkiye
Sertifika Numarası: N 19 22129 1337 00 NY

5- APPROVED ORGANIZATION:

CERTIGAZ SAS

62 rue de Courcelles, 75008 Paris / Fransa
Onaylanmış Kuruluş No: CE1312

CONCEPT TEST VE TEKNOLOJİ MERKEZİ

Köşklü Çeşme Mahallesi 577 Sokak No: 17
PK: 41400 Gebze / Kocaeli / Türkiye
IAS Akreditasyon Numarası: TL-578

6- ATIFIED STANDARDS:

EN 203-1	EN 203-2-10	EN 61335-2-48: 2003+A1:2008+A11:2012
EN 203-2-1	EN 61000-6-2: 2005	EN 61000-6-4:2007/A1/:2011
EN 203-2-7	EN 60204-1: 2018	EN 61335-1:2012/A13/2017
EN 203-2-9	EN 62233: 2008	

7- MANUFACTURER'S AUTHORIZATION:

Name and Surname: Fatih Gökbuca
Task: Quality Manager
Sign:



COMPLY WITH ALL SAFETY WARNINGS IN THIS MANUAL!



DESCRIPTION OF SAFETY INFORMATION

- The safety symbols in the manual are used to identify potential risks.
- If any safety symbols appear in this manual, it should be understood that there is a possible risk of injury or a risk to human health, and the following instructions should be read carefully to avoid possible risks.

UNDERSTANDING SAFETY WARNINGS

- This product must be installed in accordance with the applicable national and local codes of the country and / or region of installation.
- All electrical connections of this device must be made in accordance with the wiring diagram supplied with the device.
- Inside the Doner Robot inside the package, there is a User Manual electrical grid connections diagram.
- This appliance is designed for professional use only and should only be operated by qualified personnel. Assembly, maintenance and repair work must be carried out by the manufacturer or other qualified personnel.
- Installation, maintenance and repair by unqualified persons may void the manufacturer's warranty. Carefully read the operating instructions, the labels and the safety instructions on the machine.
- Make sure that the warning labels on the machine are in good condition.
- Please replace missing or defective labels. Learn how to operate the machine and how to check it correctly.
- Use your machine in suitable working environments.
- Improper modifications to your machine will adversely affect the safe operation and lifetime of your machine.

ELECTRIC SHOCKING IS DANGEROUS

- If the residual current circuit breaker and residual current protection device installed in accordance with the instructions are connected to the machine, the electrical safety of this machine is ensured. -It is extremely important that the wiring is checked by a specialist if basic safety requirements are tested and in doubt. -The manufacturer cannot be held liable for damages caused by insufficient or broken grounding lines (eg electric shock). -Periodically check all cables for possible damage and cuts. If a damaged or uninsulated cable is detected, repair or have it replaced immediately. When not use the machine, please close off. Unplug all power connections and connection plugs or turn off the machine before repairing the machine or for mechanical maintenance, daily cleaning with water.

1. Description

1.3 Safety Rules

MOVING PARTS CAN CAUSE INJURY

- Avoid moving parts on the machine. Keep away from cutting parts on the machine.
- Avoid interference by uninformed persons.
- Make sure that all spit assembly, wing, back cover, tray and wiring are correctly connected on the machine and are correctly assembled.

SMOKE AND GAS CAN BE HARMFUL FOR YOUR HEALTH

- Create a natural or artificial ventilation system in the work area.
- The gases worked with the machine are flammable, explosive and suffocating.
- For this reason, do not operate your machine without the authorized person, since the installation has been done correctly and has been checked.
- Make sure that flame carriers and flammable materials are not kept near the work area.
- In case of working with gas cylinders, make sure that the cylinders are positioned in a separate remote area and well ventilated.

HOT SURFACES AND PARTS CAN CAUSE HEAVY BURNS

- Do not touch hot parts or surfaces with bare hands.
- Allow the parts to cool down before proceeding to clean your machine.
- Use heat-resistant non-flammable gloves when handling hot parts.

MAINTENANCE OF MACHINERY, ACCESSORIES. PERSONS MAY CAUSE INJURIES

- Electrically powered devices must not be repaired or serviced by unauthorized persons.
- Failure to do so may result in serious damage to the device and injury.
- Gas-powered appliances must not be repaired or serviced by unauthorized persons.
- Failure to do so may result in serious damage to operation, explosion, injury, and death.

SAFETY WARNINGS FOR MAINTENANCE AND REPAIR

Disconnect the machine from the mains before carrying out any installation, maintenance or repair work. Electric consuming tools are powered by the customer until the main switch is turned off. Only original spare parts supplied by the manufacturer should be used for maintenance and repair. If non-genuine spare parts are used, the warranty period expires.

GENERAL SAFETY WARNINGS

Read the safety and operating instructions in this manual carefully. If the safety instructions and operating instructions are not observed, no liability or warranty can be demanded from the manufacturer. Only work with the machine when you have read and understood the instruction manual. Only operate the machine as described in the instruction manual. Warnings of possible malfunctions or damage to the product due to non-observance of the described safety precautions. Warning of possible serious or even fatal injury to persons due to non-observance of electrical safety precautions.

1. Description

1.4 Meaning of Warning Labels and Signs



Warnings of possible malfunctions or damage to the product due to non-observance of the described safety precautions.



Warning of possible serious or even fatal injury to persons due to non-observance of electrical safety precautions.

Attention

Electrical Risk



It is a warning against severe damage, suffocation and death as a result of the safety precautions and non-observance described.



It is a warning against fire, explosion and death as a result of disregard of the safety precautions and precautions described.

Gas (NG, LPG)

Flammable Environment



This is a warning against burns to the skin as a result of non-observance of the warning labels and cautions described.



The warning labels described are those where there is excessive temperature and a warning to act according to that environment.

Hot Surface

Extremely Hot Environment



As a result of non-observance of the warning labels and cautions explained, the piercing is a warning against cut injuries to the limbs and skin with the cutting blade.



It is a warning against injury in the form of trapping of limbs such as hands, head and arms as a result of non-observance of warning labels and warnings.

Cutting Tools

Moving Parts

1. Description

1.4 Meaning of Warning Labels and Signs



This is an important information and an explanation to be taken into consideration.



Safety warnings and warnings against poisoning, suffocation and death as a result of non-observance of the precautions.

Warning Information

Waste Gas Warning



This is an important information and an explanation to be taken into consideration.



This is an important information and an explanation to be taken into consideration.

Warning Information

Warning Information



Warning against skin irritation and surface defects on metal surfaces as a result of non-observance of the warning labels and cautions described.



CE marking; It is not a quality symbol, but a sign that the product on which it is attached meets all the requirements of the relevant regulation and is intended to ensure the free movement of goods between the member states of the European Union.

Harmful or Irritant

CE Marking



All parts of your machine are made of recyclable parts and materials.



Waste oil and metal raw materials produced during cleaning and maintenance can harm the environment and nature.

Warning Information

Warning Information

1. Description

1.5 Product Tags

1.5.1 Machine's Sticker

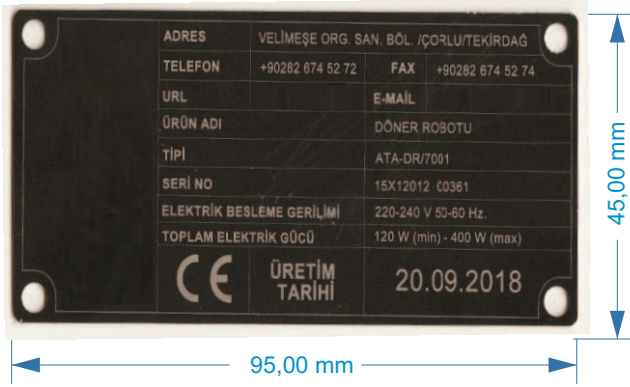

Ürün Ölçüleri:

Model:

Net Ağırlık:

Seri Numarası:

1.5.2 Cooker's Sticker

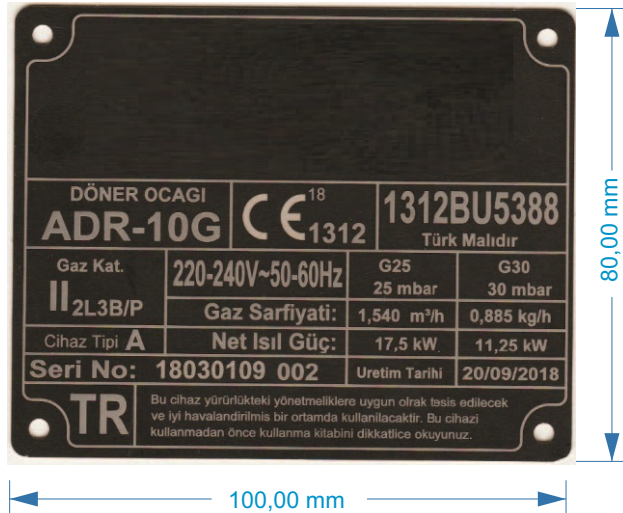

Model:

kW:

Type:

Pin No:

1.6.1.User Manual Explanation

This manual is an integral part of the ADR series Doner Robot Machine. The operating manual contains important information on safe, proper and economical use and maintenance of the Doner Robot. Observing the instruction manual helps you avoid hazards, reduce repair costs and repair times, and increase the reliability and life of the machine. All of these operating instructions and the relevant supplier documentation must be kept ready for use in the vicinity of the Doner Robot machine. Operating instructions The operation of the doner Robot is for the user and maintenance personnel. Every person responsible for carrying out work on the machine with the following tasks should read, understand and follow these operating instructions.

Things to consider when doing these things:

- Operation,
- Maintenance and cleaning,
- Troubleshooting. Safety section, read the warning notes in the text of each section.
- The user manual does not assume any responsibility for you as the operator and user personnel of the doner Robot.

1.6.2.Structure of the User Manual

The user manual is divided into 6 main topics:

- User reminders,
- Safety instructions,
- Machine data,
- Instructions on the use of the doner Robot machine,
- Guidance chart for detecting and correcting faults,
- Instructions on the operating instructions.

1. Description

1.7 Abbreviations

The abbreviations made in these operating instructions and the abbreviations known within the framework of world standards are given in the table below in detail and these abbreviations are used within the scope of the operating instructions.

Abridgement	Descriptions	Abridgement	Descriptions
CE	EU Standarts	DR	Doner Robot
Bkz.	Please Check	KK	User Manual
ŞG	Skewer Group	NG	Natural Gas
LPG	Propane Gas - LPG	AISI	Stainless Steel
G	Gas Model	E	Electric Model
Mt.	Meter	Cm.	Cm
Height	Height	Weight	Weight
Length	Lenght	Kg.	Kg
Gr.	Gr	kW.	Kw
W	W	V	V
Min.	Min	Max.	Max
GK	Wide Cutting Type	DK	Tight Cutting Type
Kcal	Kcal	mbar	mbar
∅	Diameter	UPS	Uninterruptible Power Supply
CE	EU Standarts	DR	Doner Robot

2.Transport

2.1 Upload to vehicle, Vehicle download, Placement



1. Determine the weight of the Doner Robot Machine. When doing so, check the information on the factory nameplate. If necessary, take into account the weight of the special assemblies.



2. Use suitable lifting equipment (Forklift, Pallet Truck) when transporting the Doner Robot.



3. Carefully lift the machine with a suitable lifting item.

4. Carefully place the machine on the loading platform or fixed base of the transport vehicle. Keep the machine stationary on the transport vehicle. Fasten securely with the rope to the transport vehicle construction.



5. When transporting the doner Robot, use suitable lowering tools (Forklift, Pallet Truck).



6. Carefully lower the machine with a suitable tool.

7. Ensure that the machine is transported to the place of operation with a suitable tool. (Forklift, Pallet Truck).



8. Carefully unpack the machine, starting from the top cover so that the machine is not damaged.

9. Unpack the package not damaged for re-use.

10. After opening the top cover, carefully remove the snap-in side covers.



11. Use a Forklift or Pallet Support to pick up the machine on a wooden pallet.

12. Adjust the balance of the doner Robot table by leveling it at the place where the machine will work.



13. Producer will be put into operation for the assembly and installation works after this stage. Do not carry out any installation or assembly operations other than producer information and control.

2. Transport

2.2 Considerations When Receiving

1. Standard accessories that should be on the DR should be checked and received from the written list. Any missing or incorrect parts accessory information must be reported to the producer company representative or the Sales Representative.



2. The spare parts specified in the written list with DR should be checked and received in the package. Any deficiency or incorrect parts accessory information should be reported to Producer company authorized or Sales Representative.

3. In the event of any damage, crushing, puncture and impact due to carrying DR and all kinds of accessories and spare parts that are included in the package, they should be recorded immediately with pictures or videos and should be recorded and shared with the transportation personnel or producer company customer representative.

2.3 Working

After the safe transfer to the place where the DR will be operated, the necessary installation, electrical and gas equipment must be in a connectable condition for the operation of the machine. In the event of any deficiency, the DR cannot be commissioned and operated. In addition, the necessary ventilation conditions must be provided in the place where DR will work. You can get support from your Manufacturer for ventilation technical details.



In addition, the UPS infrastructure must be available on the electrical installation side and commissioned by the Manufacturer and / or its authorized technical service from whom you purchased the UPS system. The manufacturer does not have any responsibility for the initial commissioning and commissioning of the UPS system. You are responsible for transporting the DR to the workplace. In addition, it is your responsibility to ensure that the gas installation (NG or LPG) to be used for the operation of the DR works in accordance with the project opened by the competent authorities in the required standards. Gas ventilation, installation leakage tests and other details must be carried out by you. The manufacturer has no responsibility for this issue.

2.4 Security Alerts

You are responsible for transporting the DR to the workplace. In addition, it is your responsibility to ensure that the gas installation (NG or LPG) to be used for the operation of the DR works in accordance with the project opened by the competent authorities in the required standards. Gas ventilation, installation leakage tests and other details must be carried out by you. The manufacturer has no responsibility for this issue.



3.ROBOT FEATURES AND BASIC INFORMATION

3.1 Doner Robot Description and Features

Doner robot, chicken, beef, such as meat to be given a certain form (doner turning form) as a result of the doner; It is an automatic doner cutting machine which allows the user to determine the desired criteria by the user to cook and cut to the desired thickness at maximum diameter, height and slope. The cooking unit of the appliance is prepared as electric, NG (Natural Gas) or LPG (Liquid Propane Gas) according to customer request. This appliance is intended for professional use and should only be used by trained personnel. Doner robot in hotels, restaurants, restaurants, fast food, tourist facilities, canteens, catering companies and so on. used in places.

The cooking unit of the appliance is prepared as electric, NG (Natural Gas) or LPG (Liquid Propane Gas) according to customer request. This appliance is intended for professional use and should only be used by trained personnel. Doner robot in hotels, restaurants, restaurants, fast food, tourist facilities, canteens, catering companies and so on. used in places.

Property;

1. Hygienic and untouched cutting,
2. Easy to use and no experience is needed,
3. Parts can be easily removed and removed easily cleaned,
4. Continuous rotary cutting at desired thickness,
5. Remote control thanks to the control,
6. Adjustable printing on the surface of the meat,
7. Protection of the rotating cooking speed,
8. Meat chamber with removable rails and strainer,
9. Cool cutting blade with Ø140 mm circular cutting knife,
10. Knife sharpening mode,
11. Drive of rotary drive mechanism Presence and manual doner skewer mechanism,
12. Air filter cooling fans,
13. The döner robot cooking part can move back and forth and angle can be adjusted,
14. Heat guiding and hob surface protector, blades fixed at set angle,
15. Presence of protection sheet to prevent damage to radiants during cleaning,
16. Heating unit for maintaining the temperature of the cut meat,
17. Ability to easily adapt the gas and electric type döner robot cooking part to the döner robot,
18. Long lasting radiant and wires,
19. Taps with safety valves for gas cookers,
20. Possibility of program update easily,
21. Mono phase operation, (except electric cookers),
22. Low energy consumption,
23. Manual cutting in case of any failure or power failure,
24. Complete Stainless body.

3.ROBOT FEATURES AND BASIC INFORMATION

3.2 Technical Data

The technical specifications of the ADR Series for DR are as shown in the table. The dimensions are referred to by the units specified next to the table description. Measured Dimensions are DR, trayless, trayless, tableless. The dimensions are also specified separately according to the optional Automatic Cooker Movement Mechanism. Table dimensions are also given in the other table.

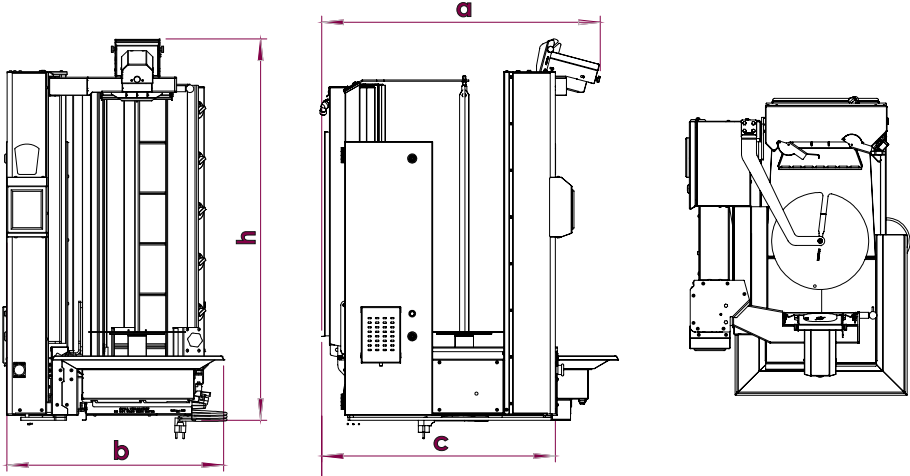

Model	ADR-M1-4G	ADR- M1-4G-GK	ADR- M1-5G	ADR- M1-5G-GK
a (Top Depth)	92 cm	92 cm	92 cm	92 cm
b (Width)	72 cm	72 cm	72 cm	72 cm
h (Height)	109 cm	115 cm	126 cm	132 cm
c (Bottom Depth)	86 cm	86 cm	86 cm	86 cm
Gas Consumption(LPG)	10,8 kW	13,5 kW	13,5 kW	13,5 kW
Gas Consumption (NG)	10,64 kW	13,3 kW	13,3 kW	13,3 kW
Burner	4	4	5	5
Weight	123 kg	126 kg	130 kg	133 kg
Power (Control)	Min 120W Max 400W	Min 120W Max 400W	Min 120W Max 400W	Min 120W Max 400W
Voltage Control	AC 220-240V 50/60 Hz	AC 220-240V 50/60 Hz	AC 220-240V 50/60 Hz	AC 220-240V 50/60 Hz

Model	ADR-M1-4E	ADR-M1-4E GK	ADR-M1-5E	ADR-M1-5E GK
Rezistans / Radyan Sayısı	4	4	5	5
a (Top Depth)	92 cm	92 cm	92 cm	92 cm
b (Width)	72 cm	72 cm	72 cm	72 cm
h (Height)	109 cm	109 cm	132 cm	132 cm
c (Bottom Depth)	86 cm	86 cm	86 cm	86 cm
Burner Power (kW)	6,4 kW	6,4 kW	8,0 kW	8,0 kW
Power / (Robot Power Control)	Min 120W Max 400W	Min 120W Max 400W	Min 120W Max 400W	Min 120W Max 400W
Voltage Robot Power	AC 220-240V 50/60 Hz	AC 220-240V 50/60 Hz	AC 220-240V 50/60 Hz	AC 220-240V 50/60 Hz
Voltage Grill Power	3 faz 50Hz 400V (380-415V)	3 faz 50Hz 400V (380-415V)	3 faz 50Hz 400V (380-415V)	3 faz 50Hz 400V (380-415V)
Weight	123 kg	126 kg	130 kg	133 kg

3.ROBOT FEATURES AND BASIC INFORMATION
3.2 Technical Data

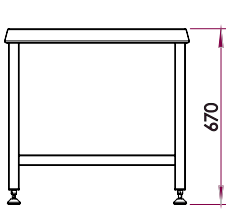

ACDRM-01

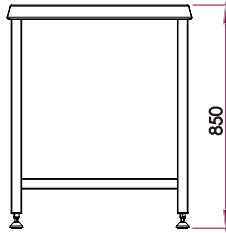

ACDRM-02

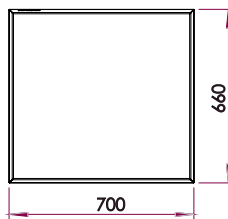
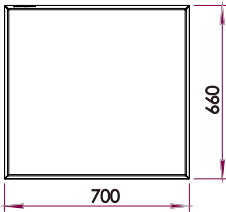
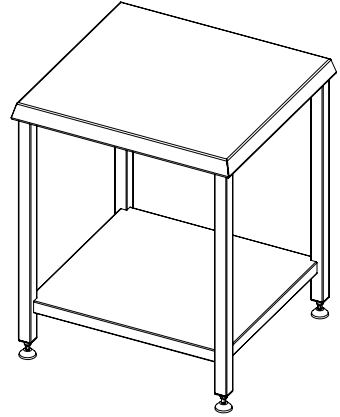

3.ROBOT FEATURES AND BASIC INFORMATION
3.3 Robot Overview and Information

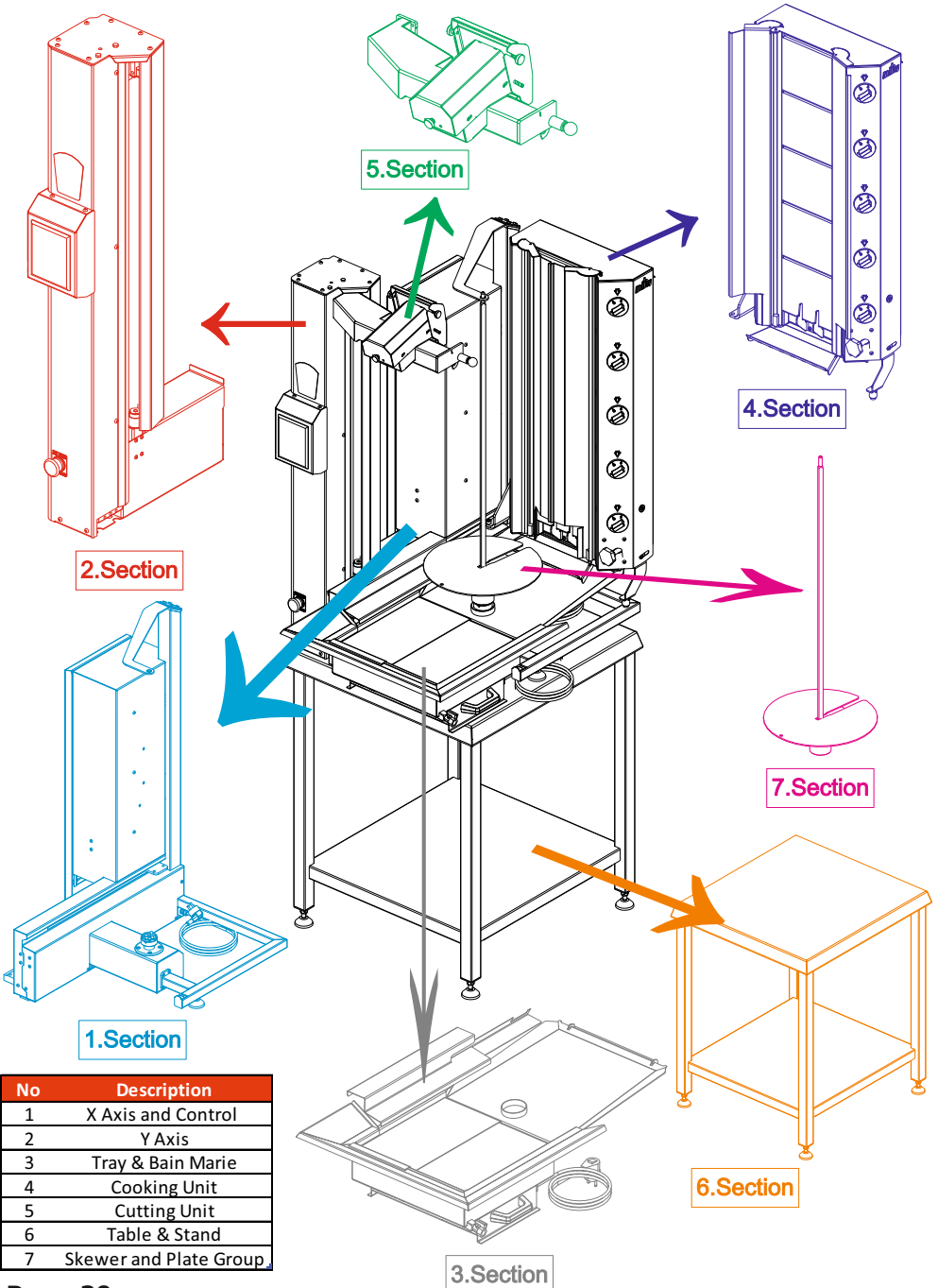

4.ASSEMBLY PREPARATION

4.1 Package Contents and Accessories from De-Mounted

In your DR order, some parts, accessories and parts are shipped as demountable. These parts must be checked and carefully removed from the package before installation and must be thoroughly checked before installation. Prior to installation, these parts and accessories are included in the factory product checklist included in the package and are shipped as assembled or de-assembled.

You or the manufacturer must carry out these checks before installation. Any missing parts should be noted for accessories and shared with the relevant persons either by means of the manufacturer or by contacting the sales representative directly.

In the DR package, the following parts comes to demountable as standard.. The first assembly must be performed by the authorized persons of the manufacturer and it should be observed that it works smoothly. After installation and use training, you can also install and demountable.

- DR Robot Table,
- Skewer Group,
- Cooker Wings,
- Trays,
- Spare Parts,
- User manual, cable and special key sets,

	<p style="text-align: center;">Attention!!!</p> <p>When opening the product package, care should be taken not to damage the product. Opening in PTSP Surveillance is recommended!</p>
---	--

Note: Some special package contents, de-assembly status may vary if additional accessories or different order parts are required to be shipped in the same package. In this case, apart from the above mentioned parts, different parts can be disassembled.

The package size and appearance of your product is shown in **Figure-1** below. Wooden pallets and packages must be heat treated in international shipments.

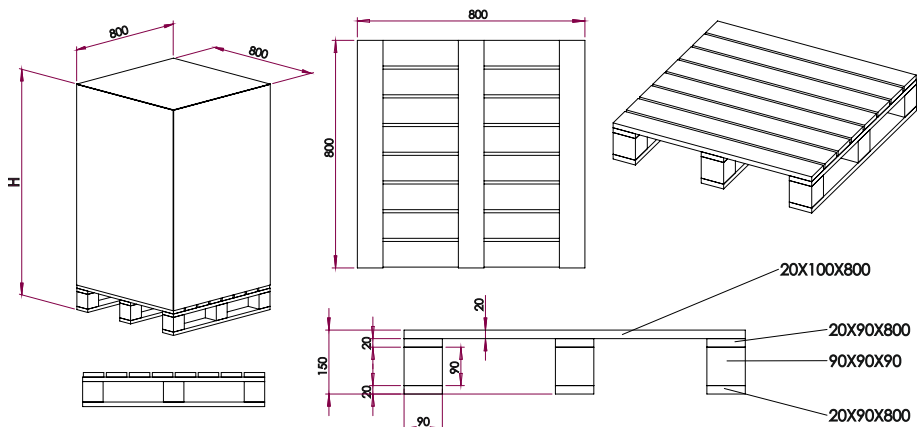

Figure-1

4.ASSEMBLY PREPARATION

4.2 Consumables and Spare Parts List

The following items will come out of the DR package. Since some of these parts will be used by mounting directly on the machine, they must be properly maintained to give to the service personnel when it comes to the authorized service installation.

Sıra	Parça No	Robot Makinesinin Bölümü	Parça Adı ve Açıklaması	Adet
1	P003497	Tool Sets	2 Wrench Allen Key (Long)	1
2	P007626	Tool Sets	2.5 Wrench Allen Key (Short)	1
3	P001940	Tool Sets	Cutting Blade Insert Switch	1
4	P060215	Tool Sets	Safe Key	1
5	P001897	Cutting Handle	Knife Sheet Cover Screw (Caterpillar Ø20 x 18 mm)	2
6	P001894	Cutting Handle	Knife Screw (Caterpillar Ø20 x 11.7 mm)	1
7	P002377	Cutting Handle	Installation Spring 0.6	1
8	P006073	Table	Rubber Table Leg	3
9	P950812	January	Cooker Connection Bolt (M8x12 Imbus)	2
10	P002014	Fog	Swivel Bottom Slot Cover	1
11	P002331	Fog	Shot Ø8	1
12	P002330	Fog	Shot Ø10	2
13	P001873	Fog	Shank Shaft Pointed Tip	2
14	P034372	Electronic	Main Power Cable	1
15	P054090	Electronic	Display Programming Cable	1
16	P051461	Electronic	Motherboard Programming Kit and Data Cable	1
17	P003495	Cutting Handle	Sharpening Apparatus Pirge (File)	1
18	P034653	Panel	Filter (120 x 115 mm)	1
19	P013452	Y Axis	Y Axis Filter (110 x 93)	1
20	P023933	Cutting Handle	Cutting Blade Cover	1
21	P021267	Cutting Handle	Single Position Gage	1
22	P002374	Cutting Handle	Cutting Blade Ø140 mm	2
23	P023937	Cutting Handle	Meat Splash Shield	1
24	P002073	Fog	Rotary Free Rotation Apparatus	2
25	P032298	Tray	Perforated Bottom Tray	1
26	P032297	Tray	Unperforated Bottom Tray	1
27	P032608	Tray	Deep Tray	1
28	P032301	Tray	Heat Shield	1
29	P024255	Tray	Heater Tray	1
30	P032300	Tray	Upper Tray-2	1
31	P032299	Tray	Upper Tray-1	1



Warning!!!
In case of missing parts coming from the package of your doner Robot, please inform the service or manufacturer. Some of the materials in the list are used with the machine and some of them are sent for installation.
Always store these materials in a safe and searchable manner.

4.ASSEMBLY PREPARATION

4.2 Consumables and Spare Parts List

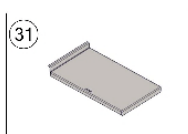
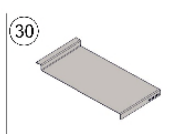
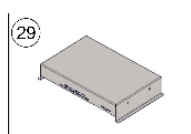
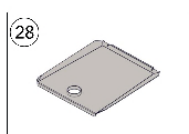
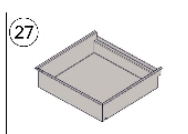
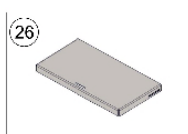
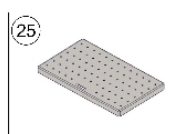
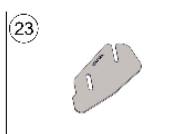
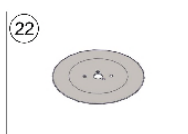
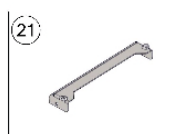
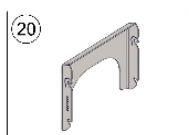
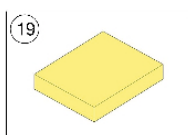
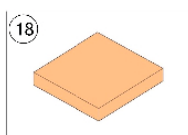
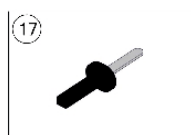
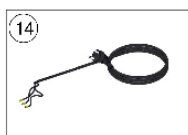
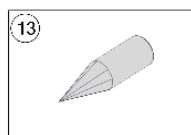
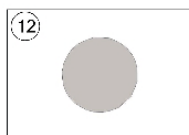
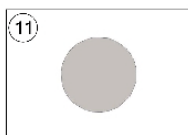
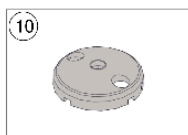
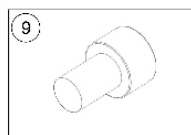
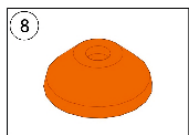
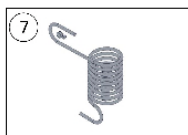
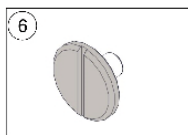
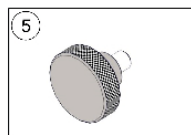
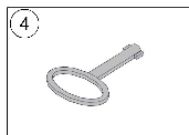
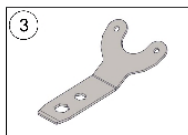
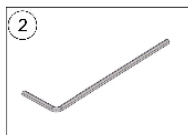
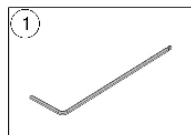

4.ASSEMBLY PREPARATION

4.3 Installation and Operation Recommendations

For safe, efficient and trouble-free operation, a suitable installation is the greatest requirement. Qualified, licensed, and / or authorized installation or service personnel, as defined in section 2 of section 1.3 of this manual, must install and service DR Using professional, licensed, and / or authorized installation or service personnel (as defined in section 1.3 of this Manual) to install or service this equipment will void the manufacturer's warranty and cause equipment damage or personal injury. Instructions and information given in this manual; In case of conflict between local, national laws or regulations, installation and use must be carried out in accordance with the laws or regulations in the country in which the equipment is installed. You can reach the service information by contacting the manufacturer.



Attention!!!

Do not connect the appliance to the mains power until you have commissioned the service center. When using the appliance, make sure that it is operated by authorized personnel for the first start-up ! Failure to do so may result in damage to your device or operating personnel!

4.3 Doner Robot Assembly

- 1. Step;** The doner robot must be transported in its package close to the place of assembly.
- 2.Step;** The package of the doner robot must be opened and the parts in the package should be neatly arranged in an empty space and checked.
- 3.Step;** Before placing the doner robot on the scale, it must be checked whether the floor on which it will be used is on the scale. If the place where the rotating robot is to be placed is not on the balance, the place where the robot will be placed should be taken to the balance before the robot assembly is performed.
- 4.Step;** The main body of the doner robot should be placed in the place where it will be mounted and its feet should be balanced. The doner robot is taken to the balance with reference to the main body.

Figure -2

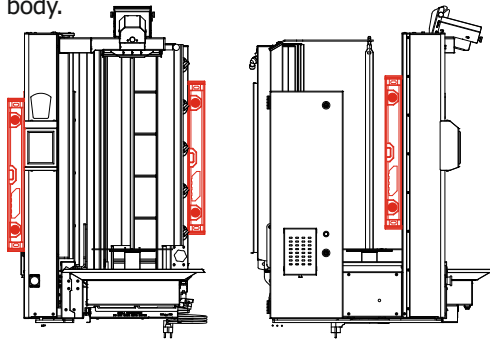

Figure-2



Warning!!!

Feeding Cable Fabrication Production Standard on Your Doner Robot
1.5 mt. Comes with cable. Doner Robot for longer cable
Use it without making additional to your needs !!!

4.ASSEMBLY PREPARATION
4.4 Doner Robot Assembly

5.Step; Blade Assembly

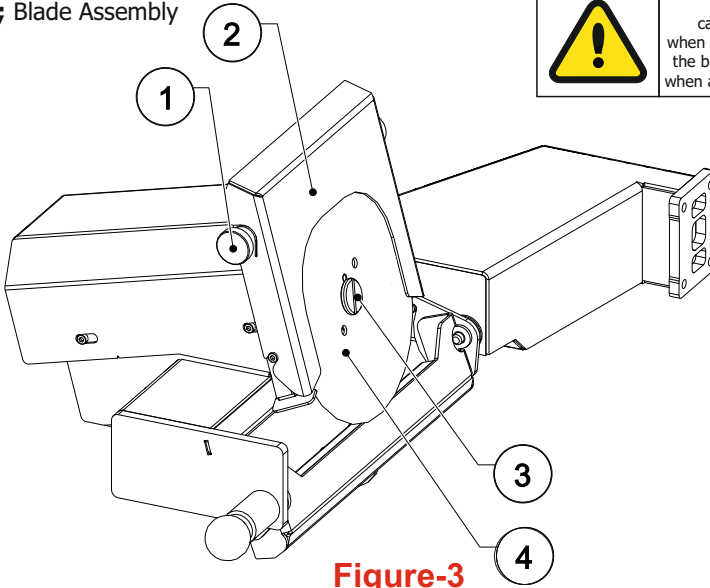

Figure-3

The parts 1,2,3,4 shown in **Figure 3** are used first for removing the doner blade. Make sure that the blade cutting unit of your machine is turned off when assembling or dismantling. Part 1 is the knife sheet protection fixing screw. Part 2 is the blade guard plate, Part 3 is the knife fixing screw and Part 4 is the doner robot blade. For dismantling, the parts 1 shown in **Figure 4** are loosened in the direction of left and right arrows. The cover plate 2 is removed. In the next step, part 3 is unscrewed with a flat lathe screw. As a result of these operations knife number 4 is removed. The procedure for assembly is reversed.

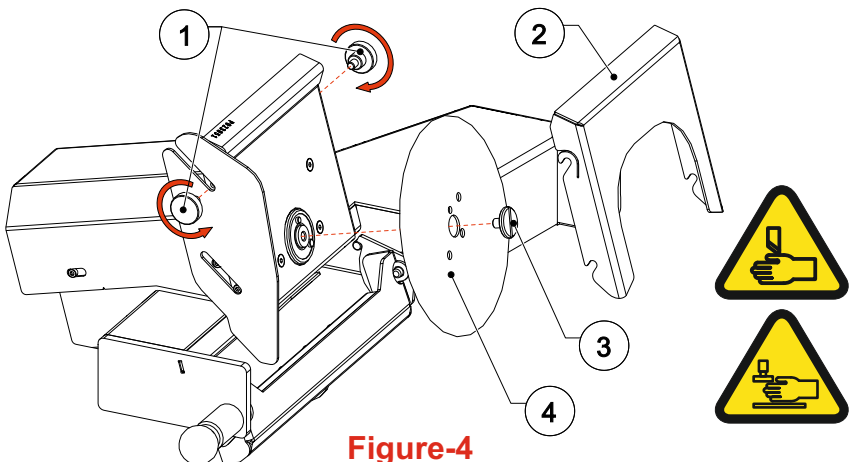

Figure-4

4.ASSEMBLY PREPARATION

4.4 Doner Robot Assembly

6.Step;

Doner Robot Installation; ADR-M1 Compact DR series has two types of doner cooker. The first is our doner cooker with manual movement mechanism. Moves back and forth with the help of hands. The second one is our döner cooker with automatic software moving mechanism. It can move back and forth automatically with user setting within the software. The mechanism according to the type and order content of the cookers is packed with the cooker assembly. Automatic moving cooker are optional. As a standard on the DR, the manual mobile cooker comes as assembled.

-Doner Cooking Assembly With Manual Movement Mechanism

The U sheet on the hob unit is attached to the profile on the body. The M8 bolts # 1 are fixed with two M8 washers to the sheet metal in the X-axis assembly as shown in detail 1.

Figure-5. With foot number 2, necessary balance adjustments are made for the balance of the robot. **Figure-7** The hob is adjusted back and forth by the handle 1. **Figure-6.** It's used manually. To reassemble the cooker unit, the process is reversed.

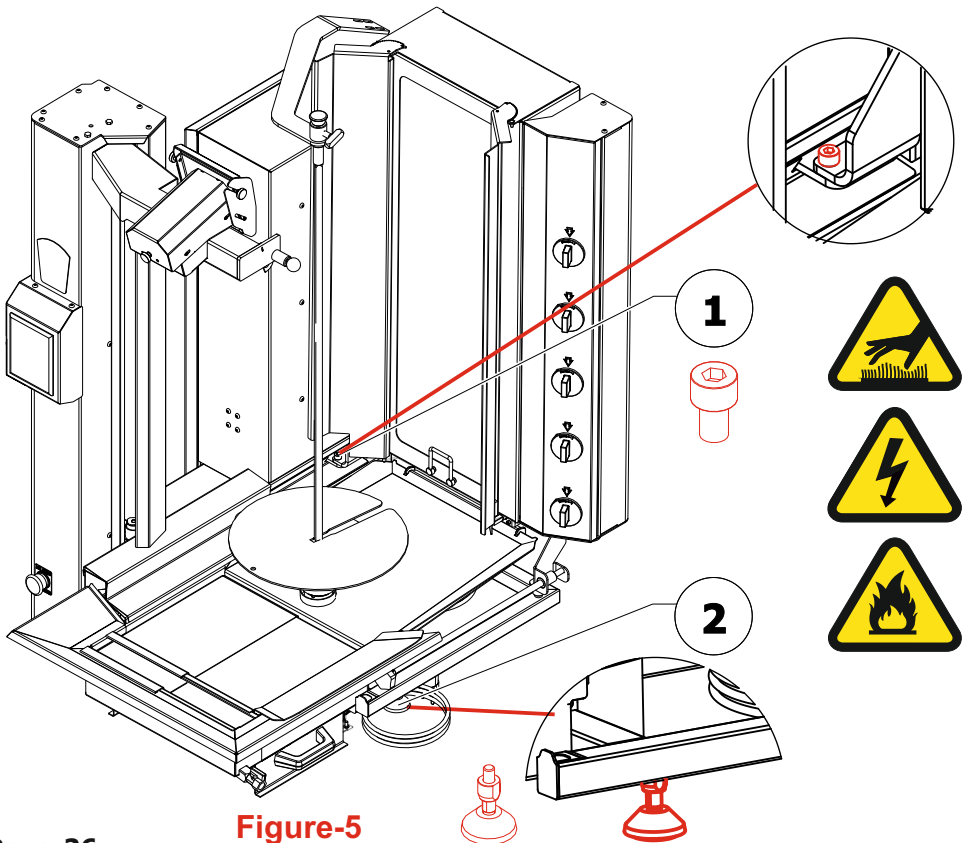

Figure-5

4.ASSEMBLY PREPARATION
4.4 Doner Robot Assembly

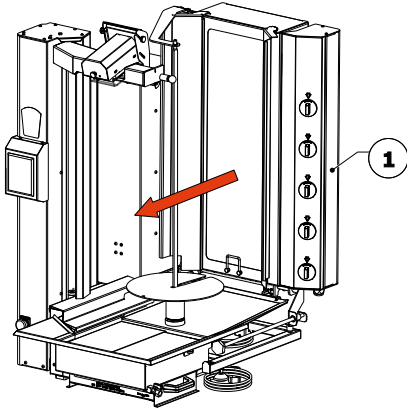

Figure-6

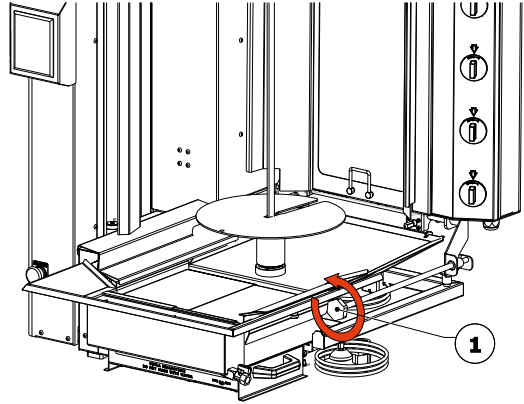

Figure-7

Automatic Moving (Software Controlled) Cookers

The hob unit is fixed to the place on the X axis by M8 bolt number 1 as shown in detail in **Figure-10**. In detail 2 on the other side, it is assembled to the place on the movement mechanism with 2 pcs M8 bolts. Once the burner is installed, no adjustment is required for positioning. When the machine is started, the hob will return to the start position thanks to the sensors. **Figure-8/9** After this step, manual intervention to the cooker unit should be avoided. The cooking part will automatically rotate skewer, Y axis and stove movement synchronously according to the program selected in the software.

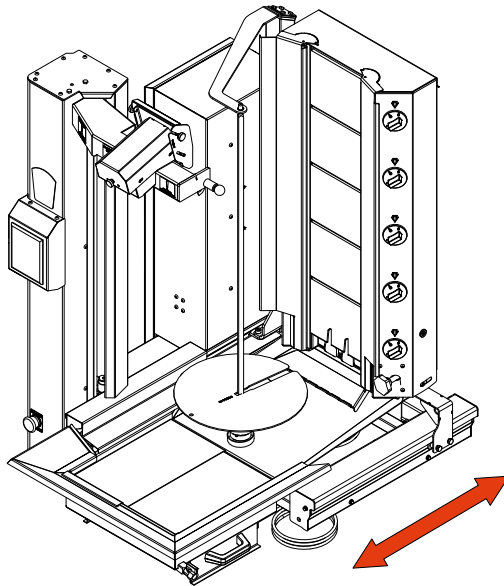

Figure-8



4.ASSEMBLY PREPARATION
4.4 Doner Robot Assembly

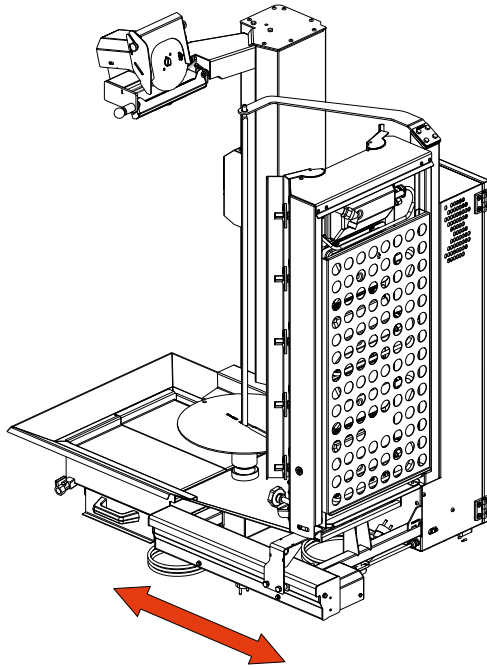

Figure-9

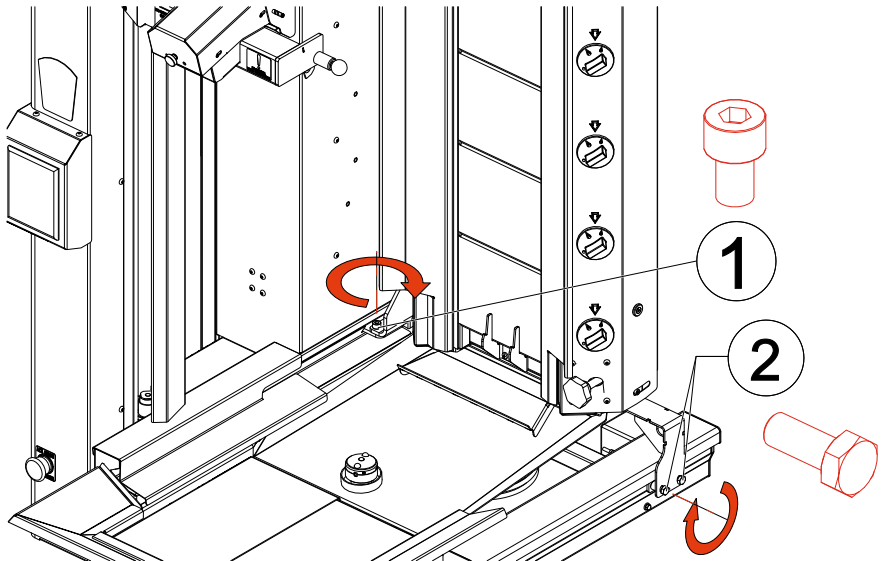

Figure-10

5.ROBOT OPERATION AND USE

5.1 Cooker Lower Tray and Bainmarie Assembly

Cooking Part Lower Tray Assembly;

Compact Series DR are equipped with a two-stage tray assembly. As shown in **Figure-11**, there is a two-piece form with two ears, which is compatible with the bottom of the 1 stovetop tray. This part 2. comes assembled on the DR. Tray 1. on the right and left holes are inserted into these ears. It is then temporarily passed through the perforated portion to the swollen hub mechanism (**Figure-12**). In the next stage in **Figure-12**, by placing the front tray group into place, tray 1. in **Figure-11** will be brought to tray 1. & Bainmari in **Figure-12** and tray assemblies will be completed.

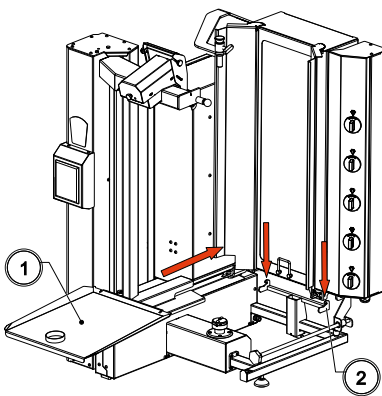

Figure-11

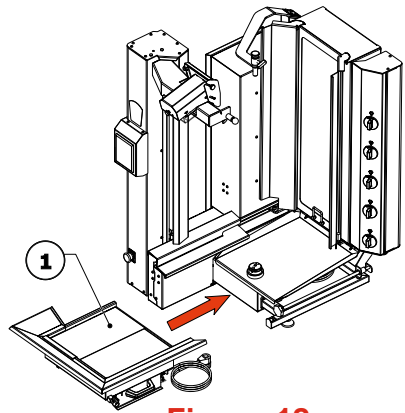

Figure-12

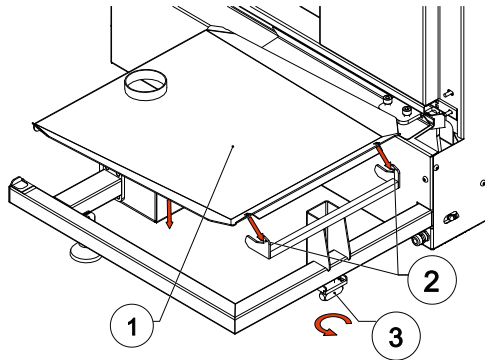

Figure-13

In the case of deterioration of the shape of the ears of the part 2 shown in **Figure-13**, which is used for the installation of the bottom tray, the bottom part of the cooker, or in the general cleaning cases, **Figure-13** can be removed by loosening the number 3 screw in the bottom part. When cleaning is finished, it is necessary to re-install and tighten the screw. It should be paid attention that it is centered according to the tray. Part 1 is inserted into these ears on number 2.

5. ROBOT OPERATION AND USE

5.2 Tray and Bainmarie Detail Assembly

Bainmarie Assembly:

After the installation of the cooking part Lower Tray described in Page 30, **Figure-14** Bainmari group in front of DR is assembled.

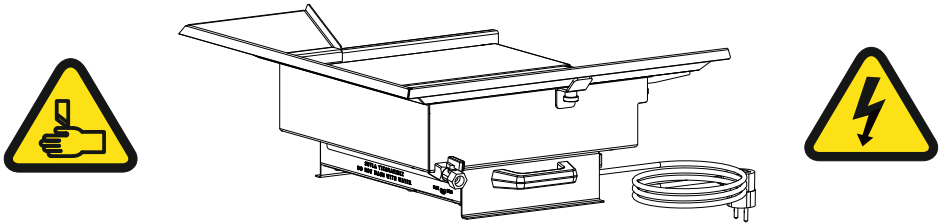

Figure-14

Figure-15 As can be seen, firstly the number one electric heated reservoir is at the bottom. In the next step, the unit number two is placed on the number one chamber such that it is between the sheet metal parts located at the bottom. It is then locked by clamping each other from the matching parts on the sheet metal part of the two opposing units (**Figure-16**). Then, the interconnected sheet metal parts with and without borehole number 3 are left free to be released into the unit number 2 as shown in (**Figure-17**). The task of the three-piece set is to ensure that cooked and cut meats remain in unit number two, and that the fat on the cooked meat is drained into the number two tray chamber. In the next step, the front part of the upper sheet metal parts four is placed in the step in the number two unit and the bent parts are placed on the number two unit. In the next step, the front part of the upper parts 4 is placed in the step in the number 2 unit, and the upper twisted parts are placed on the number 2 unit. **Figure-18**. Finally, the inclined parts number five are placed in the tray fixing lugs and other parts located on the right side of the number two unit **Figure-19**.

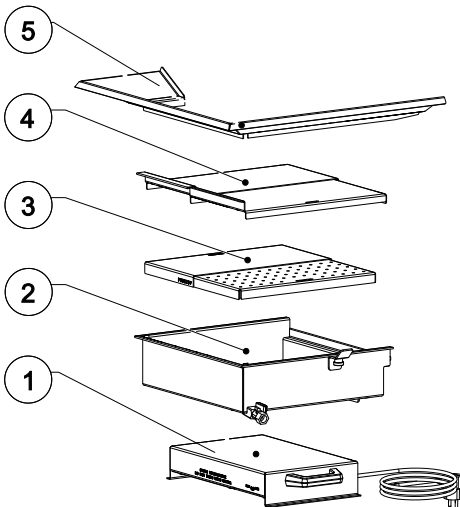

Figure-15

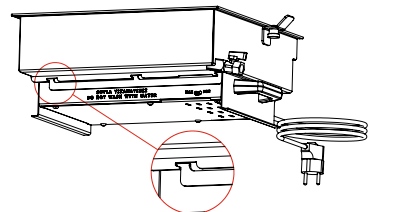

Figure-16

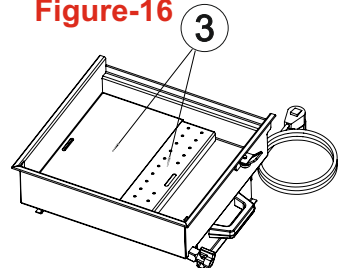

Figure-17

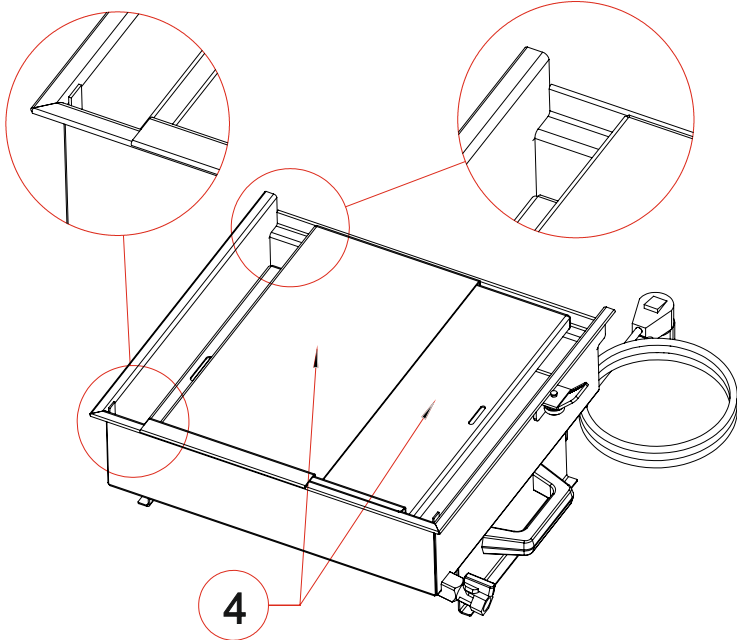

Figure-18

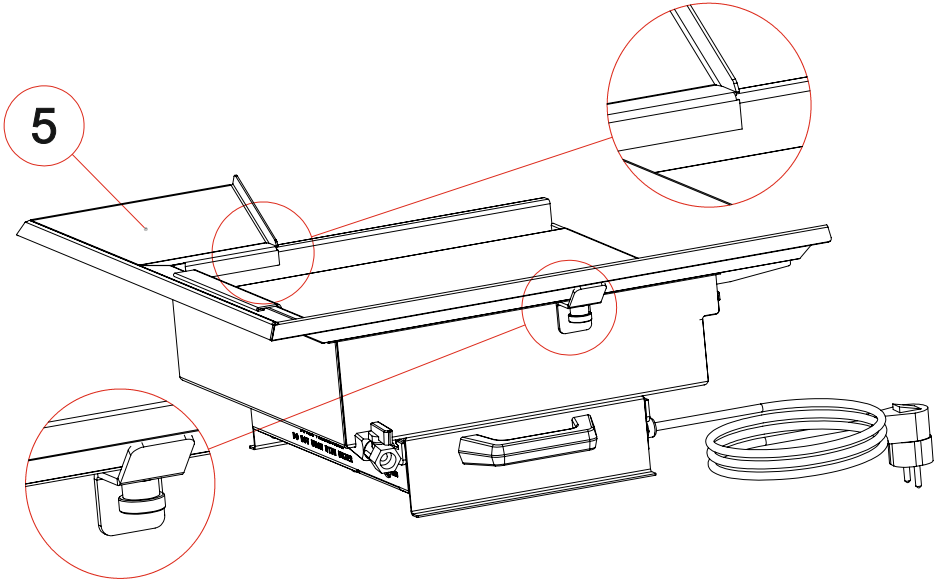

Figure-19

5.ROBOT OPERATION AND USE

5.3 Gauge Installation and Knife Sharpening

Feeling Stick Assembly:

Figure-20 is fixed by pulling the spring-loaded black knob in the direction of arrow 1, the feeling stick number 2 is pulled in the direction of the arrow to the left first and then the feeling stick is removed by pulling in the direction below. When the feeling stick assembly is done, the spring knob # 1 is pulled and the pin is taken back to the position. Then, the right side of the feeling stick is inserted into the pin opposite the number 1 knob and the left part is lifted when the hole is at the level of the pin.

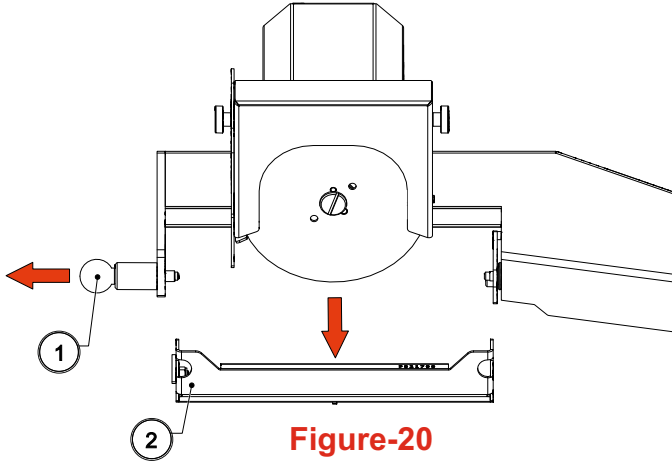

Figure-20

Knife Sharpening; While the operation is carried out, the sharpening file number 2 in **Figure-21** is touched to contact the end part of the blade number 1 so that the front surface of the blade is sharpened. In **Figure-22**, this time the grinding number 2 is brought into contact with the rear surface of the blade. When performing these operations, care should be taken not to put too much pressure on the file.

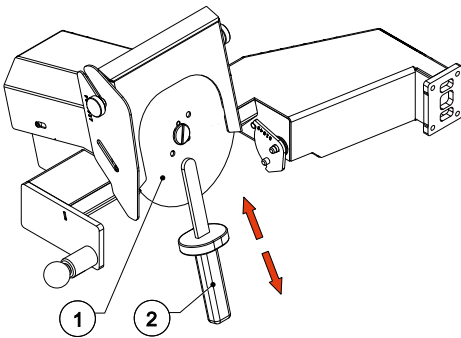

Figure-21

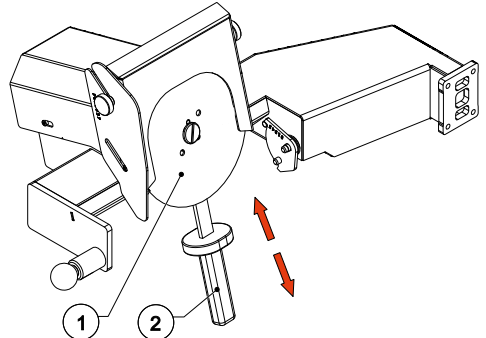

Figure-22



Protect Your Hand !!!

Hand Sharpening Apparatus When sharpening with the file, the knife is in working condition, so bring your hand closer to the knife!

5. ROBOT OPERATION AND USE

5.4 Skewer Assembly

Skewer Group Assembling; In order to assemble the skewer assembly No. 1, screw 2 must first be loosened. **(Figure-23)** Then make sure to place the lower skewer bearing part of the skewer group # 1 on the hub so that it fits into the slots. Once the hub bearing is fully seated, move it to the top of the skewer to allow it to engage in part 3. Once aligned, lift part 3 up a little so that it fits over the skewer. Then allow the nest to sit on the tip of the spit. Then tighten screw 2 to secure the skewer upper bearing. In **Figure-24** and **Figure-25**, the skewer and core ball details are shown. You should make sure that the slits in the lower part of the spit in **Figure-24** fit fully into the balls on the hub.

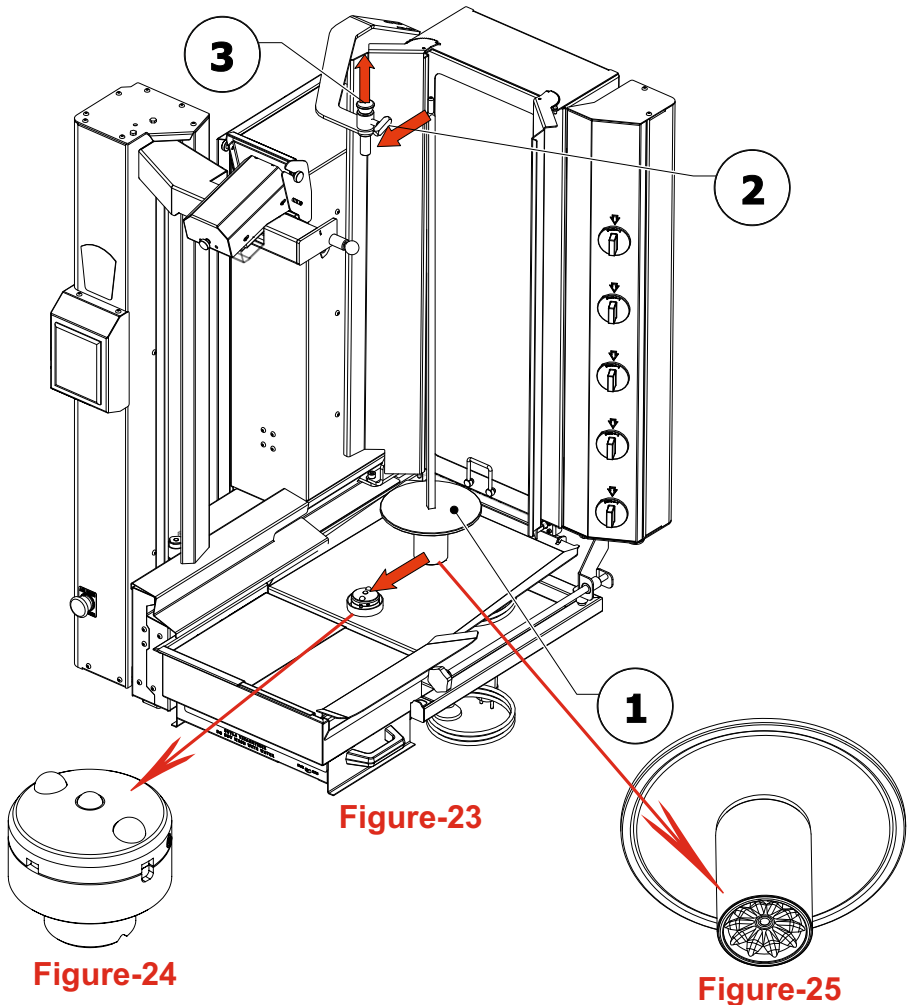

Figure-24

Figure-23

Figure-25

5.ROBOT OPERATION AND USE

5.5 Yağ Kalkanları Montajı

Dip Oil shield; The part 1 is placed in the direction of the arrow as shown in **Figure-26** and it is put into place.

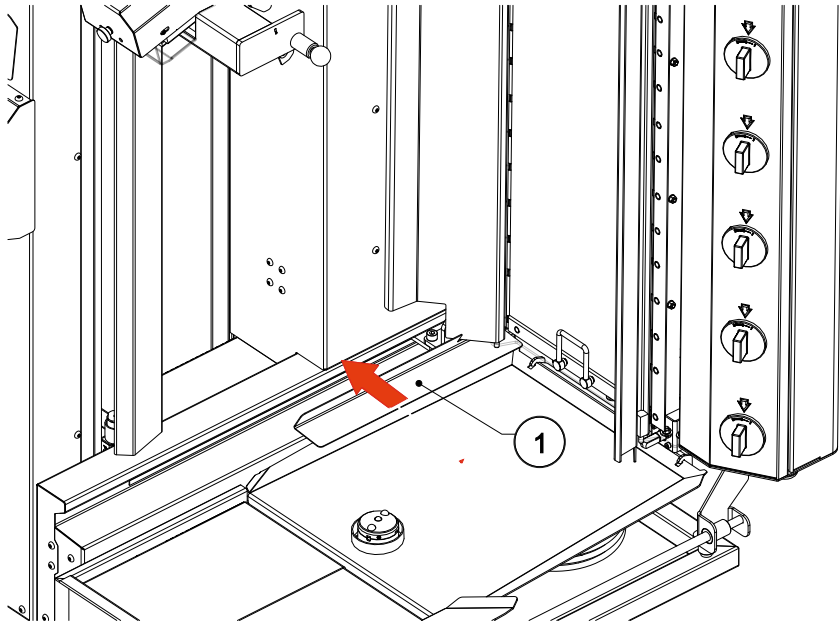

Figure-26

Oil & Meat Shield; Part 2 is placed in the direction of arrow as shown in **Figure-27**.

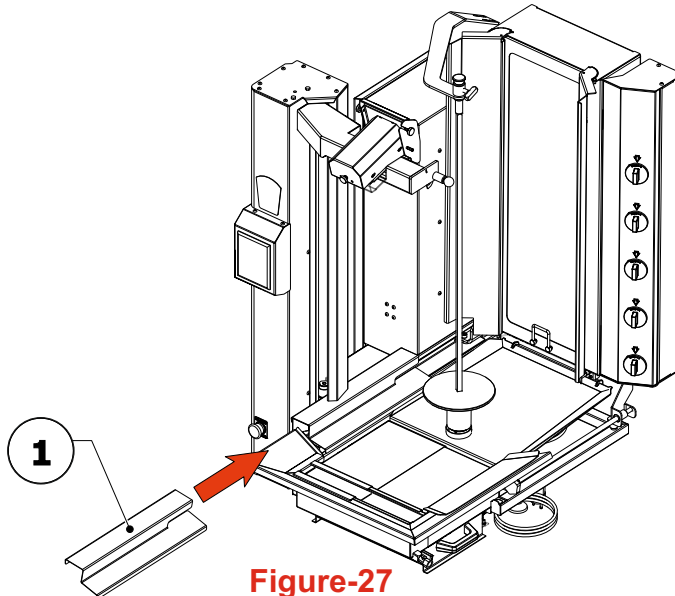

Figure-27

5.ROBOT OPERATION AND USE

5.6 Cooker Wings Assemblies and Slope Adjustment

Doner Cooking Part Wing Assembly; The wings are shown in **Figure-28** are placed in the slots in the direction of the arrow. During insertion, the lower holes and then the upper holes are inserted into the housing. When mounting, care should be taken to ensure that the direction of the wings and forms are not crooked or distorted.

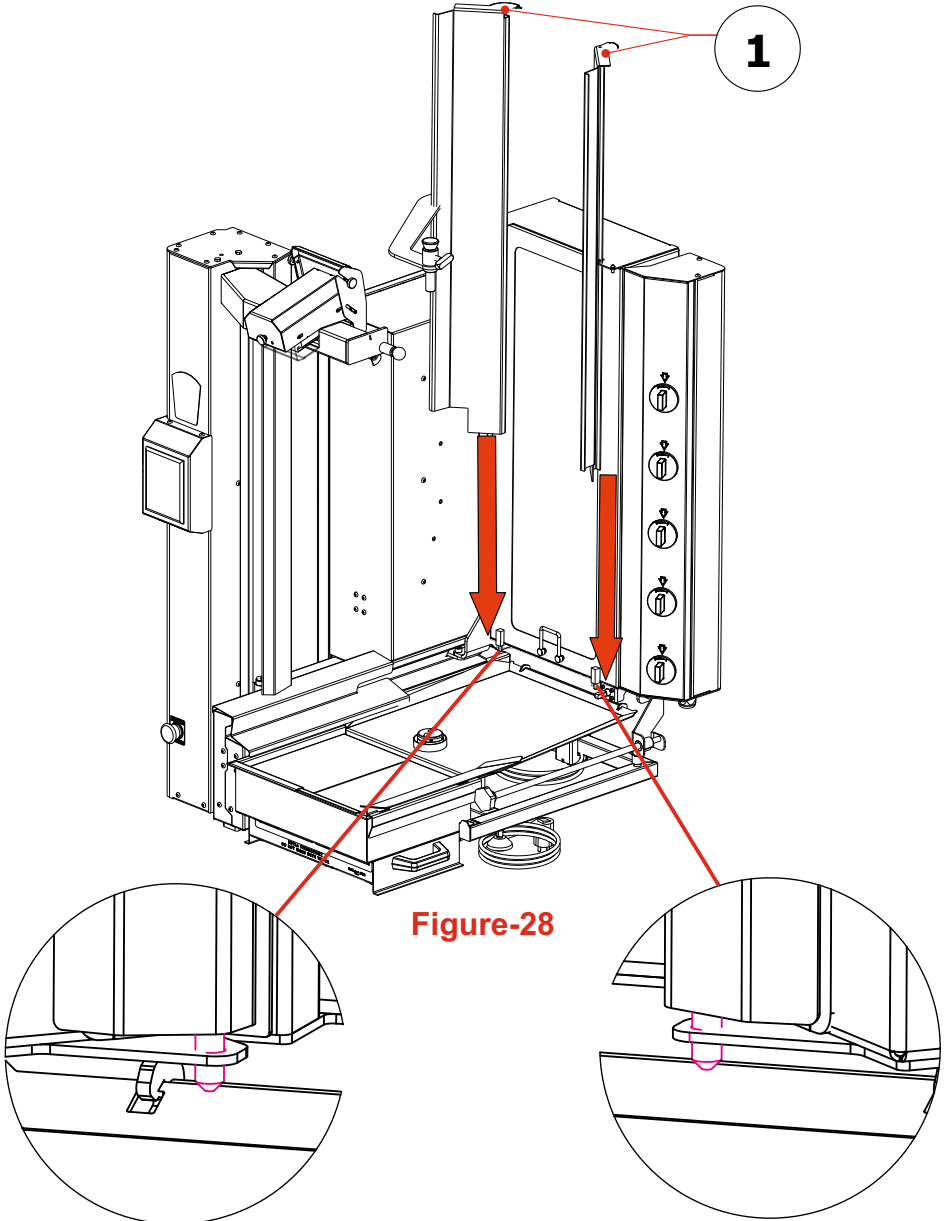

Figure-28

5.ROBOT OPERATION AND USE

5.7 Mirror Mount and Skewer Rotation Manual Mode Receive Adjustment

Cooker Slope Adjustment; Angle of the hob is adjusted by turning handle 1 shown in **Figure-29** in the direction of arrow. When turned counterclockwise, the top side of the cooker makes angular movement backwards.

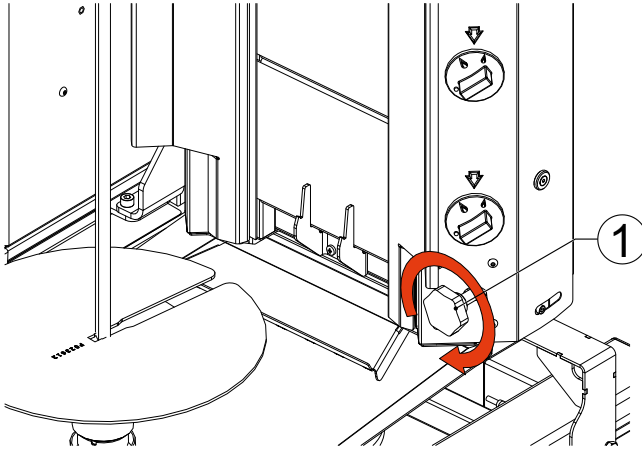

Figure-29

Mirror Assembly;

The mirror equipment 1 shown in **Figure-30** is placed in the direction of the arrow on the part 2 and it is placed in the square form of the skewer 3.

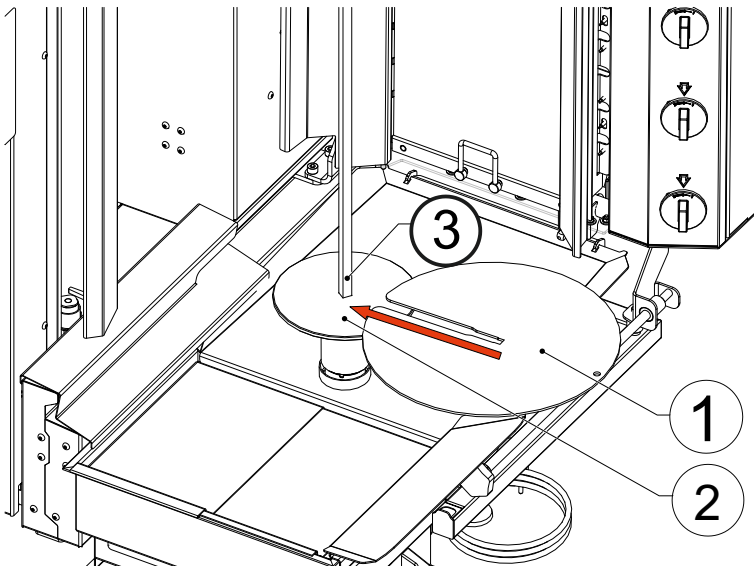
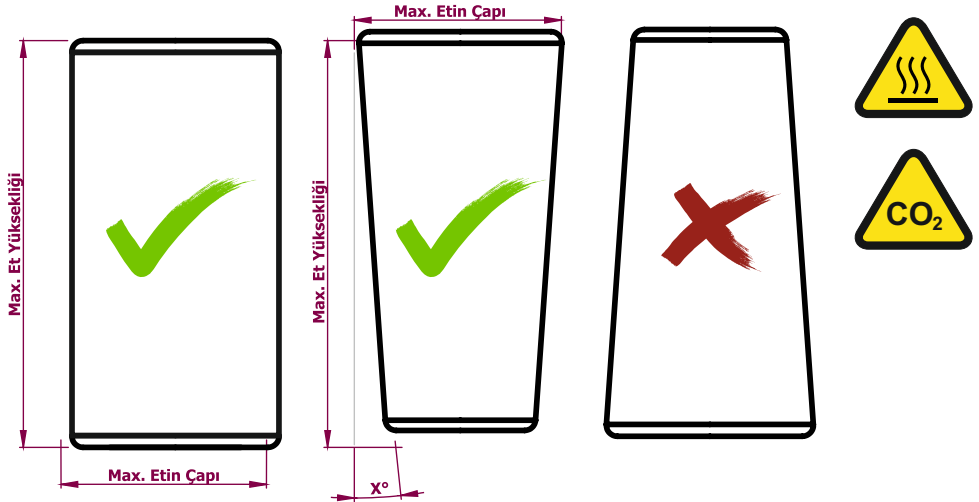

Figure-30

5.ROBOT OPERATION AND USE

5.8 Çalıştırma Hazırlık

Mechanical assembly of your Doner Robot has been completed in previous stages. The next step is to perform the necessary installation works and termination of the device. Exhaust ventilation in the ideal conditions in the environment where your machine will work, must not be prevented from entering the space free of oxygen, the necessary electrical installation and if your device is a gas model NG-LPG gas installation and fittings should be ready. At this point, the following warnings must be read and understood carefully and the necessary precautions must be taken by you. The required installation termination at the ideal distance and distance from where your machine will operate should be as follows. Do not request technical service and installation before these installations are ready. In case your Doner Robot is very undulating according to the state of the country in which your Doner Robot works, make sure to use the UPS with Uninterruptible Power Supply (UPS) for your device. The information required for the UPS selection is detailed in the electrical sections of the manual. The required form, size and other specifications according to the type and type of meat you want to cut in your Doner Robot are given below. Do not attach any product to this machine except for these measurements and information. If the doner is frozen, cutting should not be started without pre-cooking.



No	Robot Model	Max Doner \emptyset Diameter	Doner Curve Angle	Max Meat Height (cm)	Average Meat Kg. (+/- %5)
1	ADR-C1-4G	$\emptyset 44$	3	62	95
2	ADR-C1-5G	$\emptyset 44$	3	80	121
3	DRAT4E	$\emptyset 44$	3	62	95
4	DRAT5E	$\emptyset 44$	3	80	121

*Meat Density: Density is the vaule of main input.

*Yukarıdaki tablo kıyma döner etine ve $1,008 \text{ g/cm}^3$ yoğunluk değerine göre hesaplanmıştır.

6.CONTROL AND KEYPAD USE

6.1 Definitions

TIGHT CUTTING PROGRAM SCREEN USE

DEFINITIONS;

- **BEAM:** Beam is used for each of the consecutively cut surfaces.
- **START BEAM:** The first beam to be contacted by the knife when the first cut command is issued or when the cut command is issued after reset is called the Starting Beam.
- **CONTINUOUS CUT:** The turner continues to continue cutting the beams in the next round after a lap is finished. As long as it is not disabled, it continues until the end of the rotary.
- **START POSITION:** The position farthest from the doner diameter of the cutting unit in the horizontal direction and the highest position of the cutting arm is called the Start Position.



Screen-1

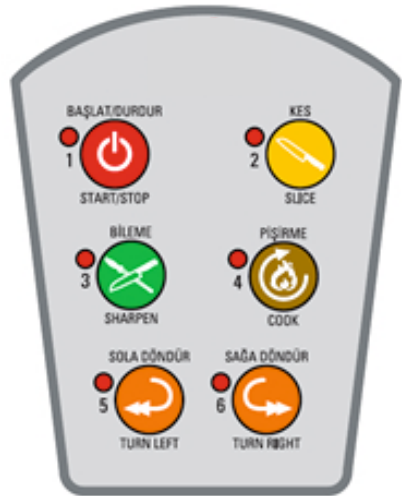

Keyboard

The **START** key (**SCREEN-1**) or the no.

1. key is used to start the doner robot (**KEYPAD**). It is used to move the doner robot to its starting position when the number 1 button (**KEYPAD**) is pressed in any position.

RESET EVERYTHING key; Used to reset the cutting beam and the starting beam. (**SCREEN-2**)

2. 1 Pressing the key once resets the position of the truncated beam by pressing twice.

3. **SLICE** key is used to send the doner robot to the section. (**SCREEN-2**)

3.1. 2 The key is used to send the doner robot to the cut. (**KEYPAD**) The continuous cutting mode is activated by pressing button 2 once during cutting. (**KEYBOARD**)

6.CONTROL AND KEYPAD USE

6.2 Start and Waiting Positions



SCREEN-2



Keyboard



SCREEN-3



SCREEN-4

1. The **GO TO THE START POSITION** key is used to return the doner robot to its starting position. **(SCREEN-3)**
2. The **INSTANT COOKING MODE** button puts the rotating robot in the standby position for the number of turns selected without waiting for the cutting round to be completed. **(SCREEN-3)**
 - 2.1. 1,2,3 The **TOUR** buttons determine how long the spin will be idle. **(SCREEN-4)**
3. **COOKING MODE AFTER CURRENT TOUR** button puts the döner robot into the standby position for the number of laps selected after the cutting tour is completed. **(SCREEN-3)**

6.CONTROL AND KEYPAD USE

6.3 Sharpening Functions Settings

4. SHARPEN Button is used to lower the robot to the blade sharpening position. Ongoing steps are as follows **(SCREEN-2)**

4.1. The button 3 is used to lower the robot to the blade sharpening position. **(KEYPAD)**

5. UNLOCK SHARPEN PROCESS button **(DISPLAY-5)** is used to switch to the next menu after the gauge is held closed. After the gauge 3 is kept closed, pressing the button again opens the sharpening lock. **(KEYBOARD)**

5.1. 1,2,3 The **TOUR** buttons determine how long the spin will be idle. **(SCREEN-4)**

6. COOKING MODE AFTER CURRENT TOUR button puts the doner robot in standby position for the number of laps selected after the completion of the cutting tour. **(SCREEN-3)**

7. SHARPEN Button is used to lower the robot to the blade sharpening position. **(SCREEN-2)**

7.1. The button 3 is used to lower the robot to the blade sharpening position. **UNLOCK SHARPEN PROCESS** button **(SCREEN-5)** is used to switch to the next menu after the gauge is held closed. After the gauge 3 is kept closed, pressing the button again opens the sharpening lock. **(KEYBOARD)**



SCREEN-5



SCREEN-6

8. UNLOCK SHARPEN PROCESS button **(SCREEN-5)** is used to switch to the next menu after the feeling stick is held closed. After the feeling stick, 3 is kept closed, pressing the button again opens the sharpening lock. **(KEYPAD)**

9. The START SHARPEN button starts the rotational movement of the blade after the gauge has been released. **(SCREEN-7)**

9.1. After releasing the feeling stick 3 the gauge is pressed again to start the knife rotation. **(KEYBOARD)**

6.CONTROL AND KEYPAD USE
6.4 Cooking and Rotation Settings



SCREEN-7



SCREEN-8

10.STOP The SHARPEN key is used to stop the blade rotation. The GO TO THE START POSITION key is used to move the robot to its starting position. (SCREEN-8)

10.1 When the knife rotates, pressing the button 1 stops the rotating movement. The robot moves to the home position. **(KEYPAD)**

11. COOK button (SCREEN-2) rotates the rotating clockwise. 4 Rotate the key clockwise to the rotator attached to the robot to start the rotation (KEYPAD).



SCREEN-9



SCREEN-10

6.CONTROL AND KEYPAD USE

6.5 Rotation Speed, Language and Reset Settings

12. The **turtle button** slows down the doner speed of the turner. **(SCREEN-9)**
- 12.1 Button 6 slows down the doner speed of the turner. **(KEYPAD)**
13. The Rabbit Key accelerates the rotational speed of the rotary. **(SCREEN-9)**
- 13.1 Button 5 accelerates the rotational speed of the rotary. **(KEY JEWELRY-MI)**
14. The **STOP COOKING** key terminates the rotary motion of the doner. **(SCREEN-9)**
15. The **MAX SPEED** key changes the cutting speed and test frequency so that it finishes the full lap cutting time as quickly as possible. **(SCREEN-10)**
16. The **LANGUAGE** button is used to select the language. **(SCREEN-10)**



SCREEN-11



SCREEN-12

17. The **RESET SETTINGS** key is used to return the doner robot to the selected factory settings or operator settings. **(SCREEN-11)**
- 17.1. The **RELOAD OPERATOR SETTINGS** key removes changes made while using the doner robot. **(SCREEN-11)**
- 17.2. The **RESET SETTINGS** key resets the doner robot to the factory settings. **(SCREEN-12)**

6.CONTROL AND KEYPAD USE

6.6 Advanced Settings and Rotating Gauge & Inclination Angles



SCREEN-13



SCREEN-14

18. Pressing the **ADVANCED SETTINGS** button opens the above menu. **(SCREEN-10)**

19. **SHAVING** button is used to smooth the surface of freshly wound doner **(SCREEN-13)**

19.1. The arrow direction button is used to adjust the thickness of the surface to be shaved. **(SCREEN-14)**

19.2 Use the **OFF** or **CANCEL** keys to activate / deactivate the feature. **(SCREEN-14)**

20. The **SLOPE FOLLOWING** key allows you to set the cutting capability of the diameter difference on the doner surface up to a maximum of 6 °. The degree can be adjusted with the right and left adjustment keys displayed in the menu. **(DISPLAY-15)**

21. The **SUMMARY** button allows all settings to be displayed on a single screen **(DISPLAY-13)**

22. **DIAMETER OF DONER** indicator shows the diameter of the doner on the robot **(DISPLAY-13)**



SCREEN-15



SCREEN-16

6.CONTROL AND KEYPAD USE

6.7 Blade Cutter Arm Speed Settings and Test Frequencies

23. The **KNIFE SPEED** key is used to set the blade's rotational speed according to the cutting speed. You can adjust the speed with the left and right arrow buttons on the menu. **(SCREEN-16)**



SCREEN-17



SCREEN-18

24. **SLICE SPEED** tuşu ile kesici kolun aşağı iniş hızı değiştirilir. **(SCREEN-17)**

25. **THE TEST CYCLE** button determines the scanning frequency of the rotary surface. The test frequency also determines the ascent speed of the cutting arm. **(SCREEN-18)**

(The higher the test frequency, the higher the cutting arm upward speed)Important

Note: The test frequency should not be increased if the doner surface is not equal at all points



SCREEN-19



SCREEN-20

6.CONTROL AND KEYPAD USE

6.8 Cutting, Beam and Print Thickness Settings

26. The **SLICE MODE** key determines the intervals of the cut. If continuous cutting mode is activated, it cuts from the start of cutting to the end of the doner. **EDGE COUNT TO BE** Cuts the number of beams set in **SLICED** mode, then waits in the starting position.

(SCREEN-19)

27. The **EDGE WIDTH** key determines the beam width on the cut surface.

Important Note: When the beam width is changed, the pressure value and thickness setting must be changed proportionally. **(SCREEN-10)**

28. The **FORCE VALUE** key is used to set the pressure value that the cutting arm unit approaches to the doner with the feeling stick. **(SCREEN-20)**



SCREEN-19



SCREEN-10



SCREEN-20

7. ELECTRICAL INFORMATION

7.1 Terms, Symbols, Definitions

TERMS, ICONS AND ABBREVIATIONS: Electron flow in a conductor.

BUAT: A box used to connect or divide the current into one or more branches in electrical installations.

ENVIRONMENTAL PROTECTION: Use of materials or processes that do not harm the environment or proper disposal of harmful wastes. **VOLTAGE:** Potential difference between two conductors.

CONDUCTOR: Materials that conduct electrical current. **GUIDE:** Steel or plastic wire used to pass conductors through pipes. **KLEMENS:** A tool for attaching conductors to each other.

CODING: Colors to be used for conductors in electrical indoor facilities (for protection conductors: green-yellow, for medium and neutral conductors: light blue, for phase conductors: different colors for each phase in accordance with applicable cable standards).

FORCE CURRENT: A current that is dangerous to people and property under normal circumstances. **MOUNTING MATERIALS:** Switch, socket, junction box cover, lamp and so on. materials.

MEASUREMENT AND DISTRIBUTION PANELS: Control panel for measuring, distributing, protecting and controlling electrical energy inside and outside the building.

RISK: A combination of the probability of occurrence of a dangerous event and its consequences.

DANGER: Potential for damages or damages that may exist or may come from outside the workplace, which may affect the employee or workplace.

INSTALLATION: Various switches, conductors, sockets, fuses and infrastructure electrical materials in line with the characteristics of the receivers (rotary robots, cookers, grills, ovens, etc.) to be used in places and installations where electrical energy (such as workplace, house, workshop and factory) will be provided according to the place of use. junction boxes, terminal blocks, pipes, etc.).

ASSEMBLY ACCESSORIES: Electrically operated devices and materials controlling these devices.

INSTALLATION PROJECT: Design including drawings and calculations of certain standards and scales in accordance with the architectural and operational scenarios project of the electrical installation to be installed,

EARTHING: Inactive parts and zero conductors in the electrical installations and the connected parts are connected to earth by means of an electrode. merge











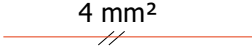



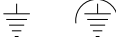



LOW CURRENT: Refers to non-hazardous current for people and property under normal circumstances.



Improper installation, adjustment and unauthorized changes or modifications to the unit may result in death. Read the installation, operating and service instructions thoroughly before installing or servicing this equipment.



7. ELECTRICAL INFORMATION
7.1 Terms, Symbols, Definitions

SYMBOL	MEANING
	Strong current supply conductor
	Grounding conductor
	Lamp
	Motor
	Ground
	Socket connection
	Insurance
	Where the cable comes from
	Where the cable goes
	Normally Closed Button
	Normally Open Button
	Fan
	Resistance
	Stepper motor
	Pako switch
	Timer
	Thermostat
	Emergency Stop Button
	Device Equivalent Potential Connection

7. ELECTRICAL INFORMATION

7.2 Network Connections



Danger to life due to living components! - The machine and any additional devices must be connected by the competent authority of the electrical installation authorized by an authorized power supply, following local regulations and regulations. Disconnect the power supply from the mains during assembly, maintenance, repair and cleaning of your machine. Check for voltage.



- If the residual current circuit breaker and residual current protection device installed following the instructions are connected to the machine, the electrical safety of this machine is ensured. It is extremely important that the home wiring is checked by a specialist if basic safety requirements are tested and suspected. The producer cannot be held responsible for damages (eg electric shock) caused by insufficient or broken grounding line.

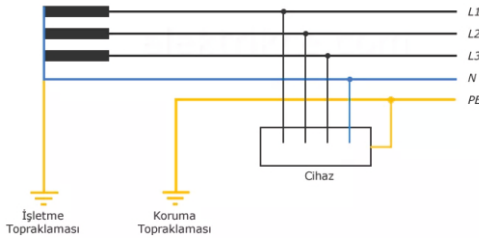

- The device may only be operated with the voltages and frequencies specified on the nameplate.
- Machines supplied without a mains plug must be connected permanently.
- The electrical connection must be protected by a separate independent safety circuit with fuses or circuit breakers. Fuses are determined according to the total connection value of the machine. The total connection value of the machine is indicated on the plate of the machine.
- Switch off the power supply using the switch on the fuse box before working on the machine. Make the electrical connections in accordance with the regulations in force.
- For your safety and the trouble-free operation of the machine, the power supply cables must be connected to a properly earthed socket.

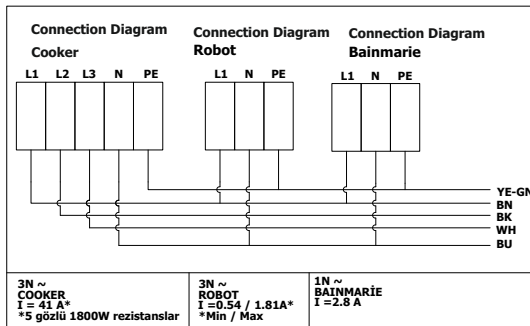

Installation, maintenance, repair and cleaning of your machine work, disconnect the power supply from the mains. Check for voltage.



7. ELECTRICAL INFORMATION

7.3 Connecting the Power Supply UPS - 3 Phase

3 PHASE INPUT 1 PHASE OUTPUT UPS CABLE DIAGRAM

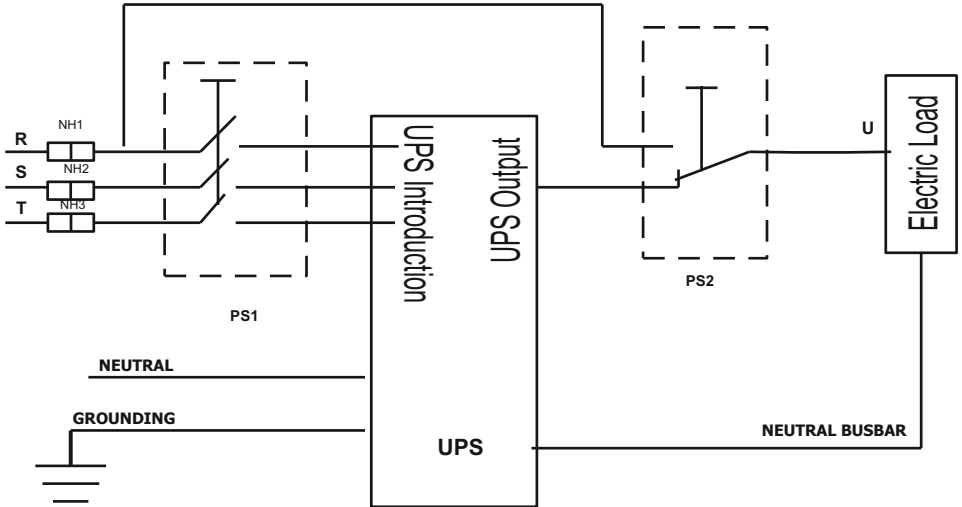

Ups Power (kVA)	Inlet Cable	Outlet Cable	Grounding Cable	NH1	PS1 (0-1)	PS2 (0-1-2)
				NH2	Positioned Pako Switch	Positioned Pako Switch
6	3x4~6mm ²	2x4~6mm ²	1x4mm ²	40A	3x32A	1x40A
10	3x4~6mm ²	2x4~6mm ²	1x4mm ²	40A	3x32A	1x40A
15	3x6~10mm ²	2x6~10mm ²	1x6mm ²	50A	3x40A	1x50A
20	3x10~16mm ²	2x10~16mm ²	1x6mm ²	63A	3x50A	1x63A
30	3x16~25mm ²	2x16~25mm ²	1x16mm ²	80A	3x63A	1x80A
40	3x16~25mm ²	2x16~25mm ²	1x25mm ²	100A	3x80A	1x125A



Warning!!!
 The values given in the table above are the average values given by UPS manufacturers. If your plumbing line is of critical length, the equipment must be selected and checked by an expert.



7. ELECTRICAL INFORMATION

7.3 Connecting the Power Supply UPS - 1 Phase

1 PHASE INPUT 1 PHASE OUTPUT UPS CABLE DIAGRAM

UPS Cable Distribution Diagram

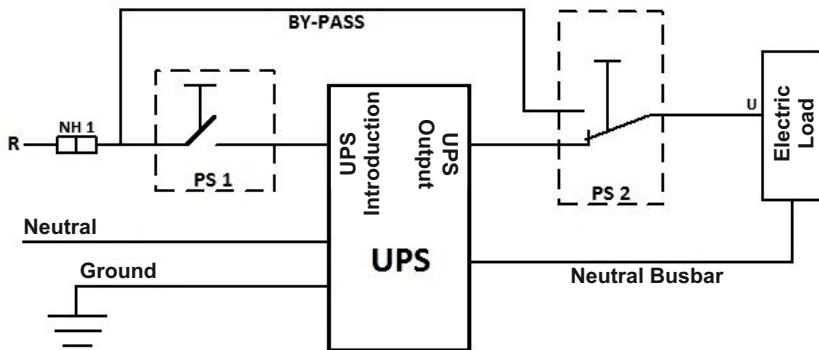
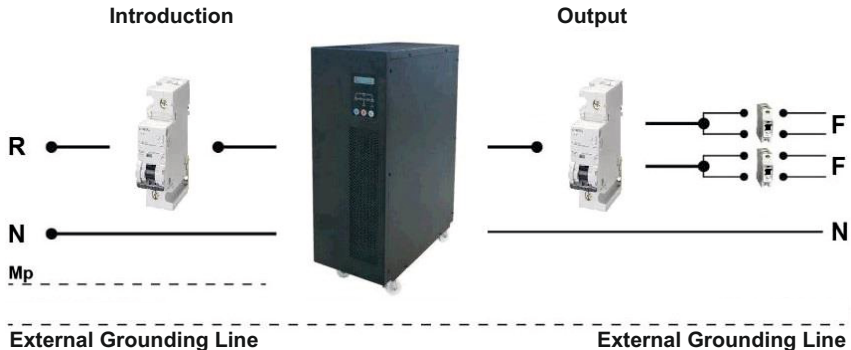

Ups Power (kVA)	Inlet Cable	Outlet Cable	Grounding Cable	V1 - V2 Switch	SG1 (0-1) Positioned Pako Switch	SG2 (1-0-2) Positioned Pako Switch
2 kVA	2X6~10mm ²	2X6 mm ²	1X6 mm ²	16A	1X16A	-
6 kVA	2X6~10mm ²	2X6 mm ²	1X6 mm ²	40A	1X40A	1X40A
10 kVA	2X16~25mm ²	2X16 mm ²	1X10 mm ²	63A	1X80A	1X80A
15 kVA	2X16~25mm ²	3X16 mm ²	1X10 mm ²	63A	1X80A	1X80A

Warning!!!

The values given in the table above are the average values given by UPS manufacturers. If your plumbing line is of critical length, the equipment must be selected and checked by an expert.



7. ELECTRICAL INFORMATION

7.4 Emergency Stop Button

The fuse of the power line to the device must be opened before using the device. Then, the robot is energized by pressing the start button on the power control panel. If the start button is not pressed, the emergency stop button may remain pressed. In this case, the number one emergency button in **Figure 31** should be turned off by turning it clockwise.

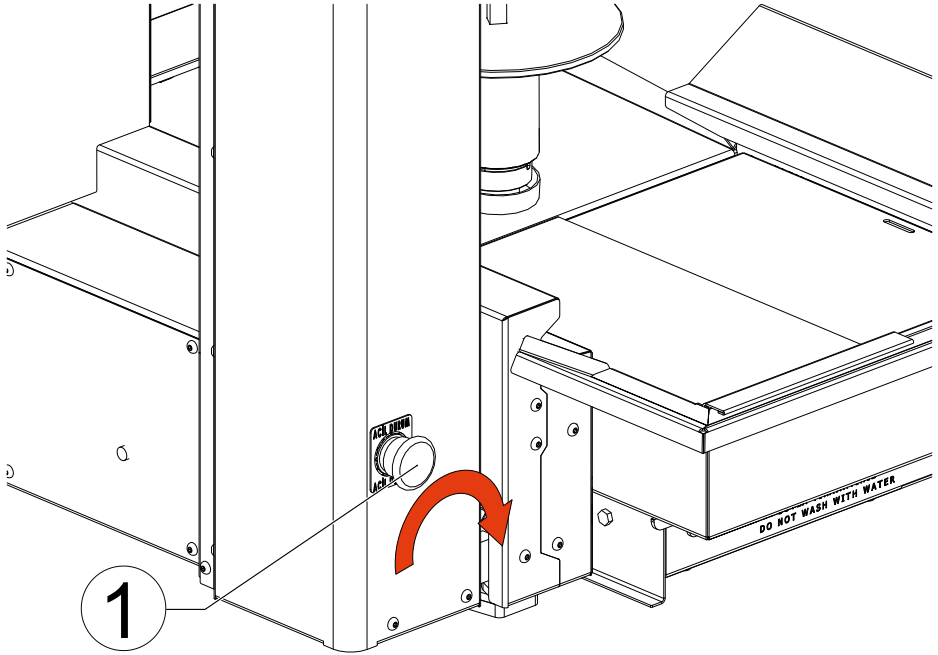

Figure-31



Warning!!!
The Emergency Stop Button must be used for emergencies.
It is not the on / off button of the robot.
Do not use continuously and unnecessarily!



7. ELECTRICAL INFORMATION

7.5 Use of Robot in Power Failure

Manual Rotation; The number one döner skewer shown in **Figure-32** will need to be switched to manual rotate mode with possible power failure while the rotator is rotating on the skewer. In order to be able to enter the manual rotation mode, firstly the double-sided setscrews of the upper cover part number 4 are removed, then the number 5 rotating shaft moves the lower bearing balls down by ninety degrees with the wrench number 6. Manual rotation is possible in this position. The center ball number three is contacted from the center of the number one döner bottle to manually rotate. For motor-driven rotation mode, 90 ° rotation is performed with the sixth month switch. The side balls 2 are moved upwards to bring them into contact with the slits under the rotating barrel. After this process, the skewer is manually rotated by hand so that the side balls with number two fit into the slots in the bottle.

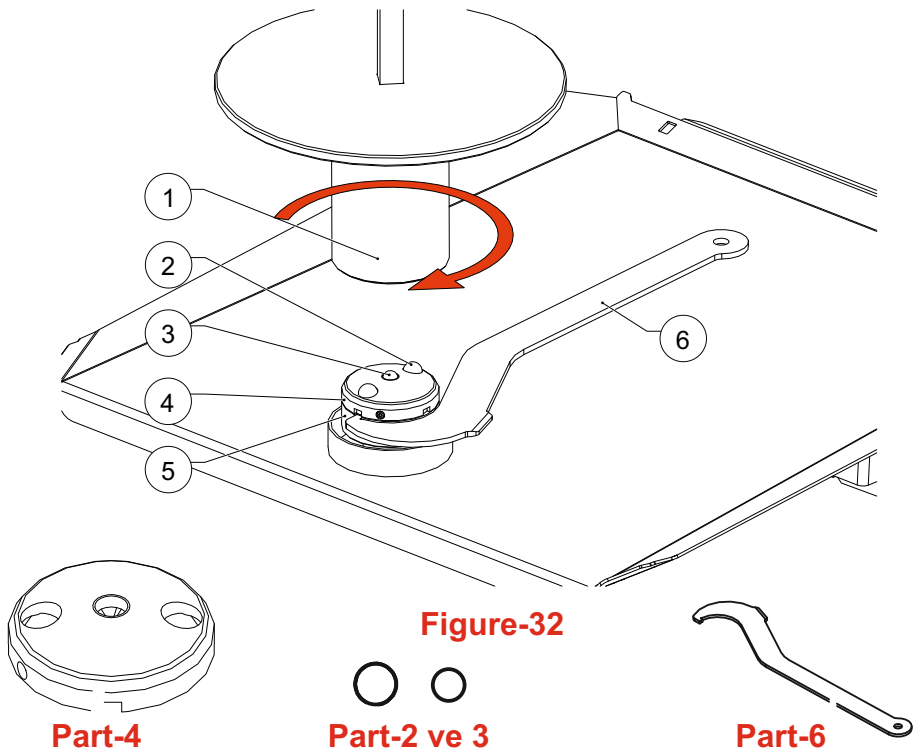

Figure-32

Part-4

Part-2 ve 3

Part-6



WARNING!!!

When the power fails, the adjustment made on the skewer hub on the skewer rotating motor must be reset. Otherwise, your robot will start, but the rotating spindle will not work.

7. ELECTRICAL INFORMATION

7.6 Use of Manual Robot in case of Electrical & Electronic Failure

In the event of failure or failure of your electronic robot (**cutting unit, drives and motors**), you can switch to the operating mode (**Manual**) of your robot, as in a conventional bottom motorized rotary kiln. The procedure for this is described below.

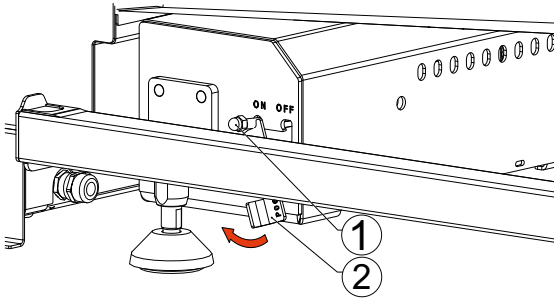

Figure-33

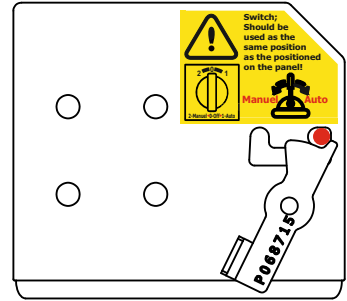

Figure-34

When the number one switch on the skewer rotating assembly of your **Figure-33** rotary robot is in the Auto position in the right direction as in **Figure-34**, the use of the standard automatic robot is active. In case of failure or error of one of the electronic components of the robot, the number one switch in **Figure-33** can be used by switching the switch to Manual position. For manual or auto operation, the button on the switchboard and the switch ever on the turntable must be in the same position! While the number one key position is changed in **Figure-33**, the number two locking sheet part (**Figure-33**) is brought to the same position and prevents the number 1 key from moving. If you want to use your robot in Auto mode again, the process is reversed.

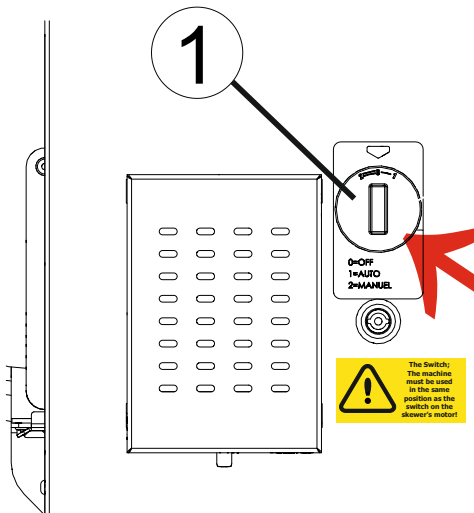

Figure-35

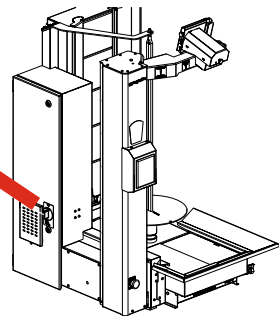

Figure-36

Note: The feature described in point 7.5 is not a feature of the standard robot model. The option must be specified in the order as a feature.

8. MAINTENANCE AND CLEANING ISSUES

8.1 Daily Cleaning of the Robot

Switch off all electrical components and gas connections before cleaning the device. Most of the moving parts of the device on the body can be removed and washed. (Except heating tray) Care must be taken that these parts do not deform during and after the washing process. The cutting blade must also be removed and washed in the same way.



WARNING !!!
Do not wash your Doner Robot with water other than the specified parts and accessories !!! If you do, it will damage the electronic components of your robot.



The cutting head should be wiped with a hygienic damp cloth. All other contaminated areas of the device must be cleaned by wiping with a damp, warm cloth. The surface tracking apparatus (gauge) bed should be cleaned from the front and back so that no parts can be left on a daily basis. Since the gauge itself and the slot where it is installed is not cleaned daily because too much oil and small pieces of meat come at the time of cutting, it will cause the gauge to not work correctly. Remove the covers on the back of the hob by first pulling



WARNING !!!
Protect your hand from cutting parts on your Doner Robot! Use gloves for blade cleaning! Failure to do so may result in damage and problems in the form of injury !!!



them upwards and then towards you and clean them in this way. Wipe the appliance with a cloth dipped in warm and soapy water before cooling. Care must be taken to protect radiants from chemical cleaning products. If chemicals are used to clean the radiants, the pores on the radiant will fill up after a while and reduce the combustion efficiency. Do not use any cleaning agents or tools that could scratch the surface of the appliance. Use chemical cleaners if necessary. Never clean the device with pressurized water or pressurized steam pressure. Never clean the appliance with water from the ventilation openings.



WARNING!!!
The oil on the hob and tray blades must be carefully cleaned on the robot. Failure to do so will cause problems such as oil flames.



Do not leak water and chemicals into the engine while removing and cleaning the spit core. Oil accumulation occurs in certain areas of the device on daily use. These sections should be cleaned regularly. If not cleaned, it may catch fire and cause a fire. Therefore, show the necessary importance for daily cleaning.



WARNING !!!
After turning off your Doner Robot, allow it to cool to clean! High-temperature surfaces can cause burns to your hands and body!



8. MAINTENANCE AND CLEANING ISSUES

8.1 Periodic Maintenance

No	Care Frequency	Sections and Care Utility	Check	Complete	Clean	Grease	Mode	Change
1	Daily	Tray			0			
2	Daily	Grill Wings	0		0		0	
3	Daily	Skewer			0			
4	Daily	Plates			0			
5	Daily	Knife	0		0			
6	Daily	Tracking Apparatus	0		0			
7	Daily	Bain Marie Water	0	0				
8	Daily	Pillars	0				0	
9	Daily	Knife remover Part	0		0		0	
10	Daily	Tracking Apparatus Base	0		0			
11	Daily	Heat Protector	0		0			
12	Daily	Oil Protector	0		0			
13	Daily	Splashing Protector	0		0		0	
14	Daily	General Cleaning						
15	Daily	Gril Back Cover						
16	Monthly	Arm Fan Filter	0		0			
17	Monthly	Y Axis Motor Filter	0		0			
18	Monthly	X Axis Cover Filter	0		0			
19	6 Months	Y Axis Rails	0		0	0		
20	6 Months	X Axis Rails	0		0	0		
21	6 Months	Injectors	0		0			
22	6 Months	Thermocouple	0				0	
23	Yearly	Y Axis Rails	0		0	0		
24	Yearly	X Axis Rails	0		0	0		
25	Yearly	Injectors	0		0			
26	Yearly	Thermocouple	0					
27	Yearly	Socket Connections	0		0			
28	2 Yearly	Burners	0					0
29	2 Yearly	Arm Fan Filter	0		0			
30	2 Yearly	Y Axis Motor Filter	0		0			
31	2 Yearly	X Axis Cover Filter	0		0			



WARNING!!!

The above maintenance, inspection and cleaning chart is the time specified by the manufacturer. These times may vary depending on your usage and density. This table does not constitute a liability for the manufacturer.



WARNING!!!

Waste oil and metal produced during cleaning and maintenance raw materials harm the environment and nature.

9. PROBLEM SOLVING

9.1 Possible Faults and Solutions

No	Faulty Type	Possible Reason	Solution and Suggestions
1	Knife Spinning Problem	Meat May Stuck	Knife should check and if there is a meat , it should be clean.
		May Driver Faulty	Driver led should be check by panel. If led lamp does not work maybe socket is not properly fitted. If problem continue, should apply to technical service.
2	Problem of cutting parts faulty (not closing to the meat)	Tracking apparatus may be heavy dirty.	Tracking Apparatus should keep clean. Do not let the tracking apparatus stay dirty for long time.
		Tracking apparatus spiral may be broken	Spiral should be change.
		Tracking apparatus may not be properly installed.	Tracking apparatus should be check.
3	Noise from the knife	Problem of knife below part modification.	Removal closer parts should be modify again.
4	Unproper spinning of Knife.	Knife may not be properly installed	Knife installation should be check. If there is unwanted pieces at the center should be clean.
		Knife may be harmed by force	Should be check by related scale tools, and knife should be change.
5	Having problem with removal of Knife	May be it is screwed too tight.	Do not screw too tight when you install the knife.
6	Unstable surface problem of the meat.	Knife cover may not be properly install.	Close the knife cover properly.
		Grill wings may not properly installed.	Wings and Doner whould be positioned as there is a proper gap between them.
7	Cutting line problems	Skewer body may not properly installed.	Skewer should be properly installed to the skewer hole.
		Unproper gap between skewer and meat hole.	Meat hole hose should be suitable with the skewer and should not have so mauch gap.
8	Non stop Idle Turning Problem	Skewer may not be properly based.	Properly base the skewer to the skewer base.
		Skewer may be programmed as manuel mode and not re programmed.	Manuel mode should be re taken.
9	Plate Removal Problem	Plates may not be properly installed	Problem can be solve as plates positioned properly.
		Plates may not be properly lined.	Plates lining should be done properly as the bottom smallest plate and the top biggest one.



WARNING!!!

Possible problems, errors and malfunctions are given in the table above are general quick simple solutions that the manufacturer foresees and the authorized operator will solve. The manufacturer is not liable for any damage caused by unconscious intervention other than those described.

9. PROBLEM SOLVING

9.1 Possible Faults and Solutions

No	Faulty Type	Possible Reason	Solution and Suggestions
10	Stuck at the axis move	There can be some part lead to axis move.	All the materials around the axis of the robot should be clean.
11	Faulty of Bain Marie	Can be out of water	Bain Marie Unit water should be check properly.
		Cable must be damaged or unplugged	Cable should be check every daily routine, and if the cable damaged should be change.
12	Unproper actions of Doner Robots	Voltage fluctuation may acquire	Fluctuation of the electrical voltage according to the country where product based. In this case please use UPS. (Check user manual)
		May be grounding problem	Grounding system should be check at the facility.
13	Meat splashing problem	Knife may be spinning too fast	Knife spinning spin should be adjust at proper level
		May be Meat splashing apparatus is missing	Use meat splashing apparatus
14	Cutting head crush to the doner	Tracking apparatus may not be installed	Install the tracking apparatus
		Tracking apparatus may not be properly installed	Install the tracking apparatus properly



WARNING!!!

Possible problems, errors and malfunctions are given in the table above are general quick simple solutions that the manufacturer foresees and the authorized operator will solve. The manufacturer is not liable for any damage caused by unconscious intervention other than those described.

9. PROBLEM SOLVING

9.2 Warranty Certificate and Warranty Terms

WARRANTY CONDITIONS

1. The warranty period starts from the date of delivery and is 1 (one) year.
2. It is covered by our company's warranty including all parts of the goods.
3. If the goods fail within the warranty period, the time spent in repair is added to the warranty period. The repair period of the goods is maximum 30 (thirty) working days. This period starts from the date of notification to the service station of the failure of the goods, in the absence of the service station, to the seller, dealer, agent, representative, importer or manufacturer-manufacturer of the goods. If the malfunction is not remedied within 15 working days, the manufacturer-manufacturer or Importer; until the repair of the product is completed, another product with similar characteristics shall be allocated to the use of the consumer.
4. If the goods fail within the warranty period due to defects in materials and workmanship or assembly, repair shall be made under no charge under the cost of labor, replacement part cost or any other name.
5. Although the consumer's right to repair the goods;
 - Within one year from the date of delivery to the consumer, provided that they remain within the specified warranty period; In addition to the fact that the same fault is repeated more than two times or different faults occur more than four or the sum of different faults is more than six within the specified warranty period, these faults make it impossible to benefit from the goods.
 - Exceeding the maximum time required for repair,
 - In case the service station of the company is not available, it can be determined by the report prepared by the seller, dealer, agent, representative or importer that the repair of the failure is not possible, in case the consumer can request free replacement of the goods, reimbursement or price reduction at the rate of defect.
6. Malfunctions caused by the use of the goods contrary to the points stated in the instruction manual are not covered by the warranty.
7. The Ministry of Customs and Trade may apply to the General Directorate of Consumer Protection and Market Surveillance for any problems arising from the warranty certificate.

SERVICE / IMPORT COMPANY

CENTER :

TELEPHONE :

:

:

FAX :

FACTORY :

:

:

:

FAX :

9. PROBLEM SOLVING

9.3 Warranty Certificate and Warranty Terms

WARRANTY CERTIFICATE

Product Type	:
Brand of Product	:
Product Model	:
Product Serial Number	:
Warranty Period	
Maximum Repair Time	
Invoice date	
Invoice number	
Place of Delivery to Consumer / Date	



Empty rectangular box for text or content.

Empty rectangular box for text or content.

10. ADDITIONAL

10.1 Circuit Diagrams - Network & Device Connection

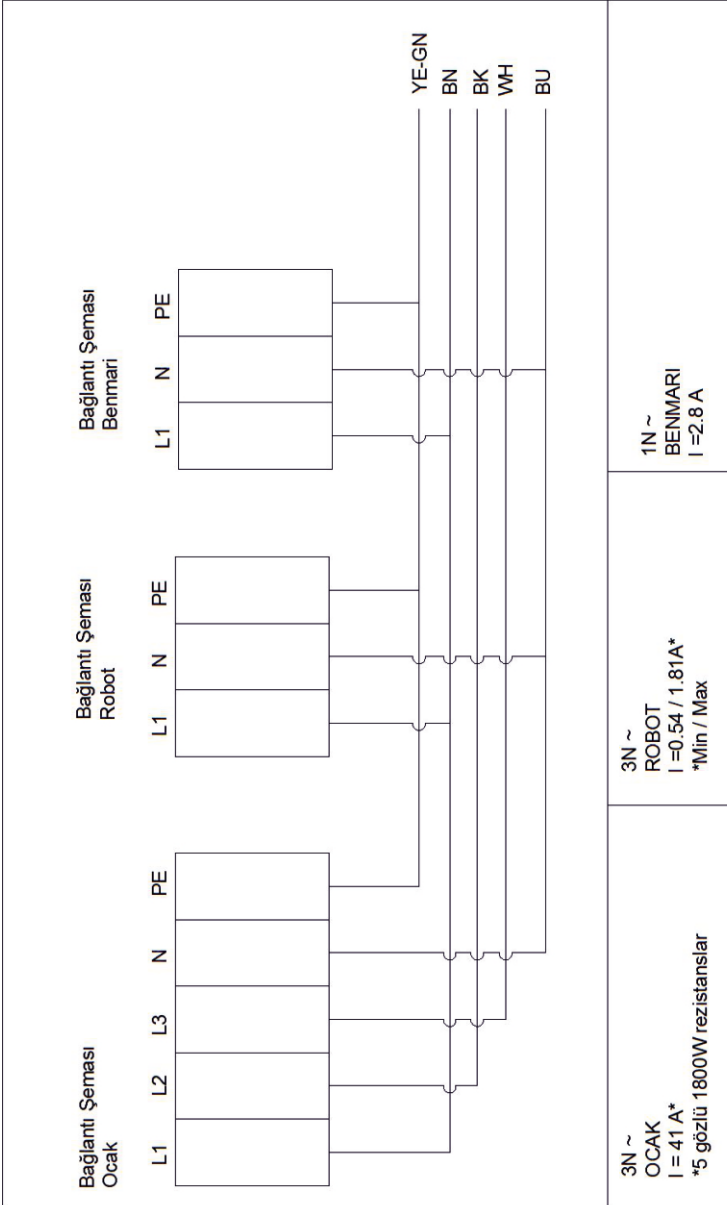

10. ADDITIONAL

10.1 Circuit Diagrams - 3 Phase Supply Distribution

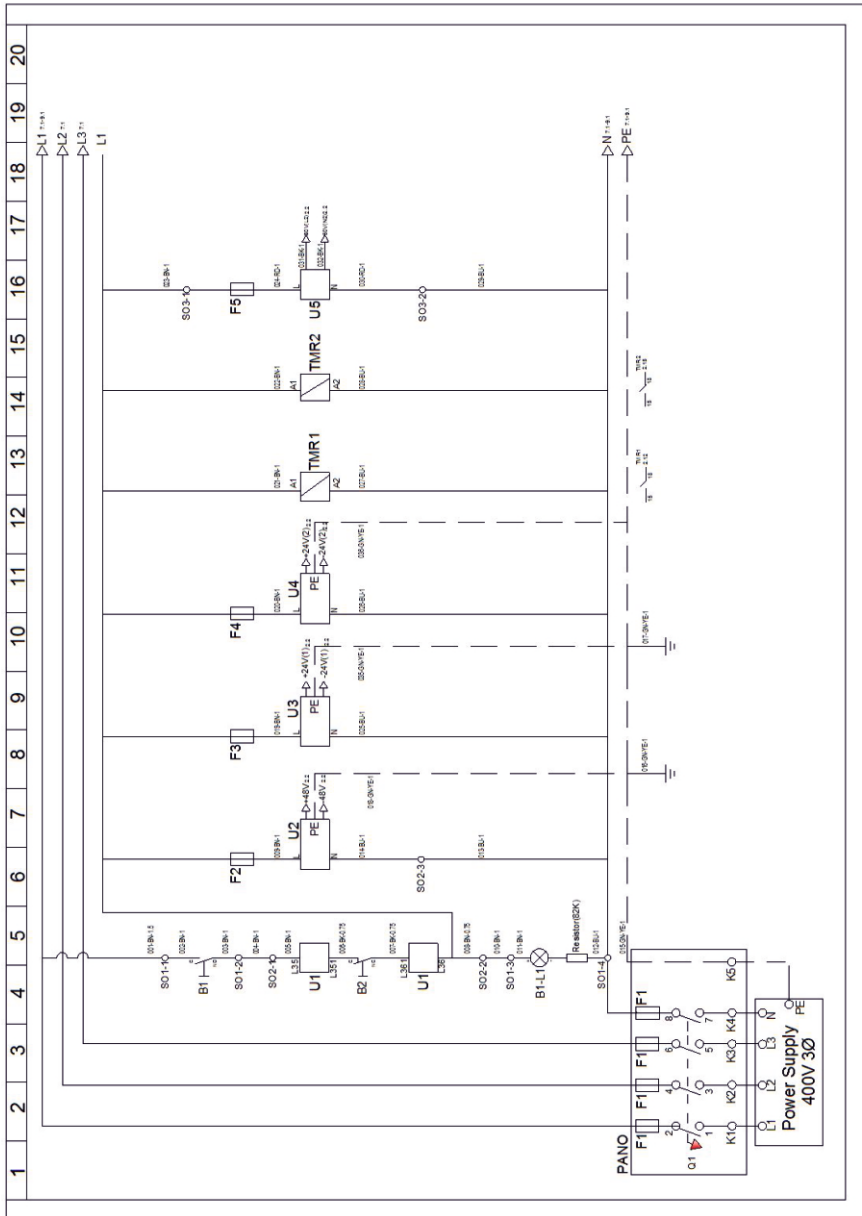

10. ADDITIONAL

10.1 Circuit Diagrams - Engine & Keypad

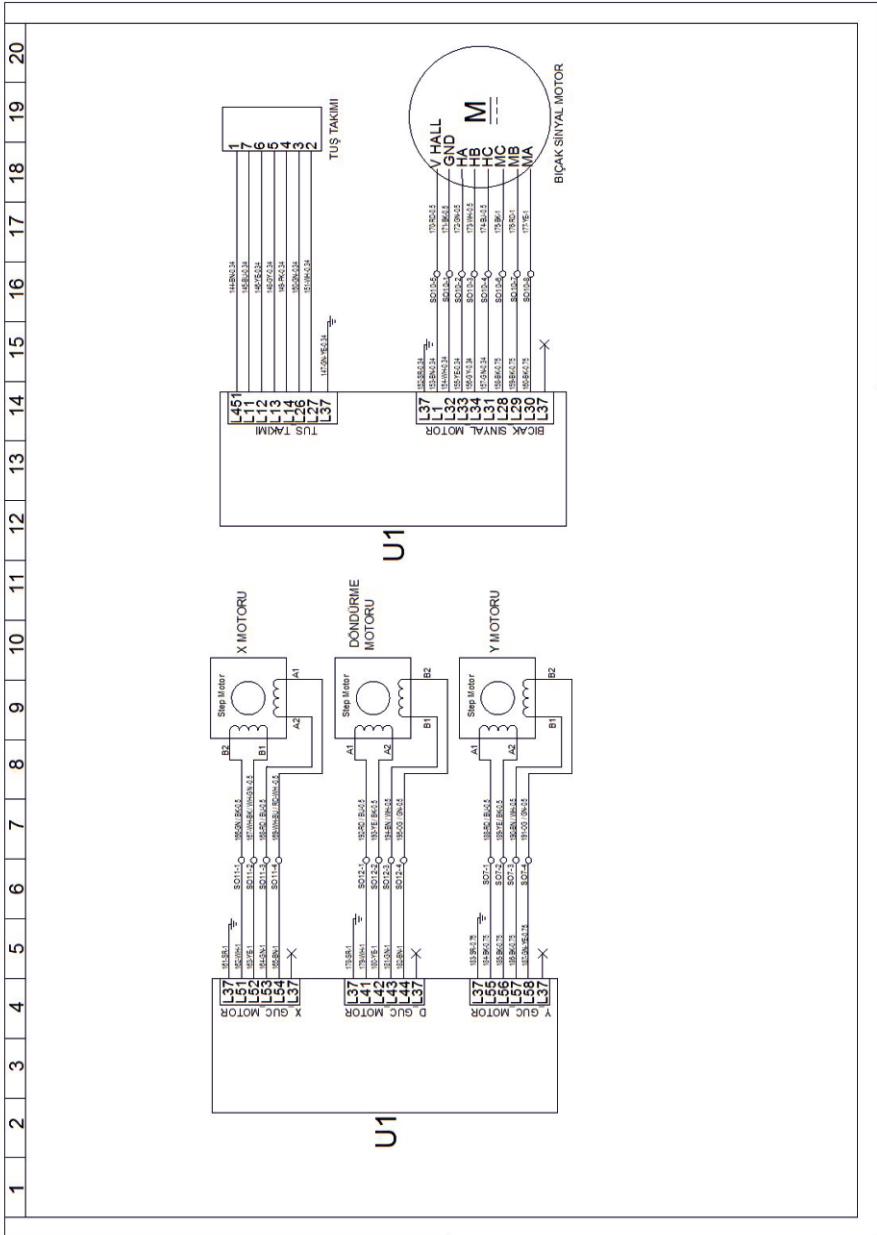

10. ADDITIONAL

10.1 Circuit Diagrams - Driver, Display and Sensors Circuit

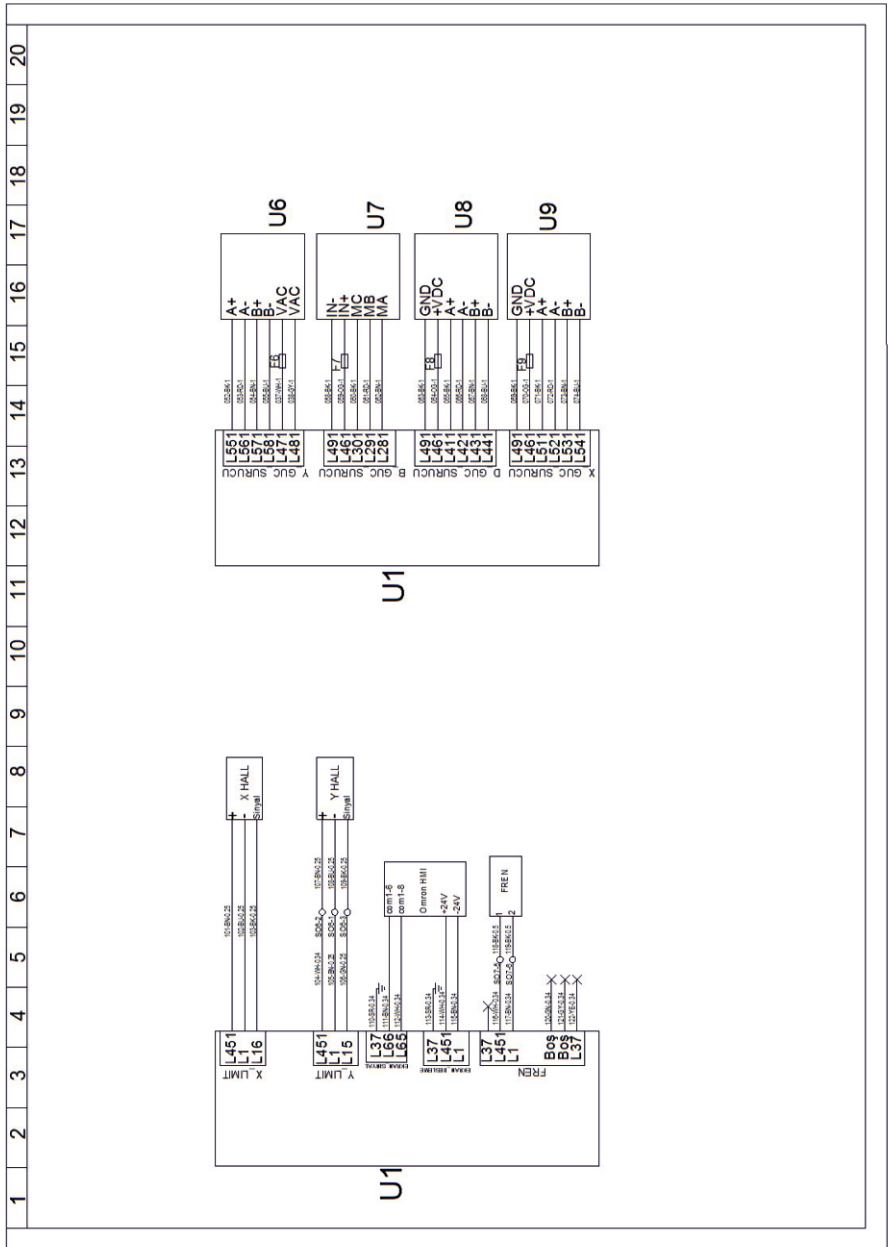

10. ADDITIONAL

10.1 Circuit Diagrams - Driver Signal, Fan and Encoder Supply Circuit

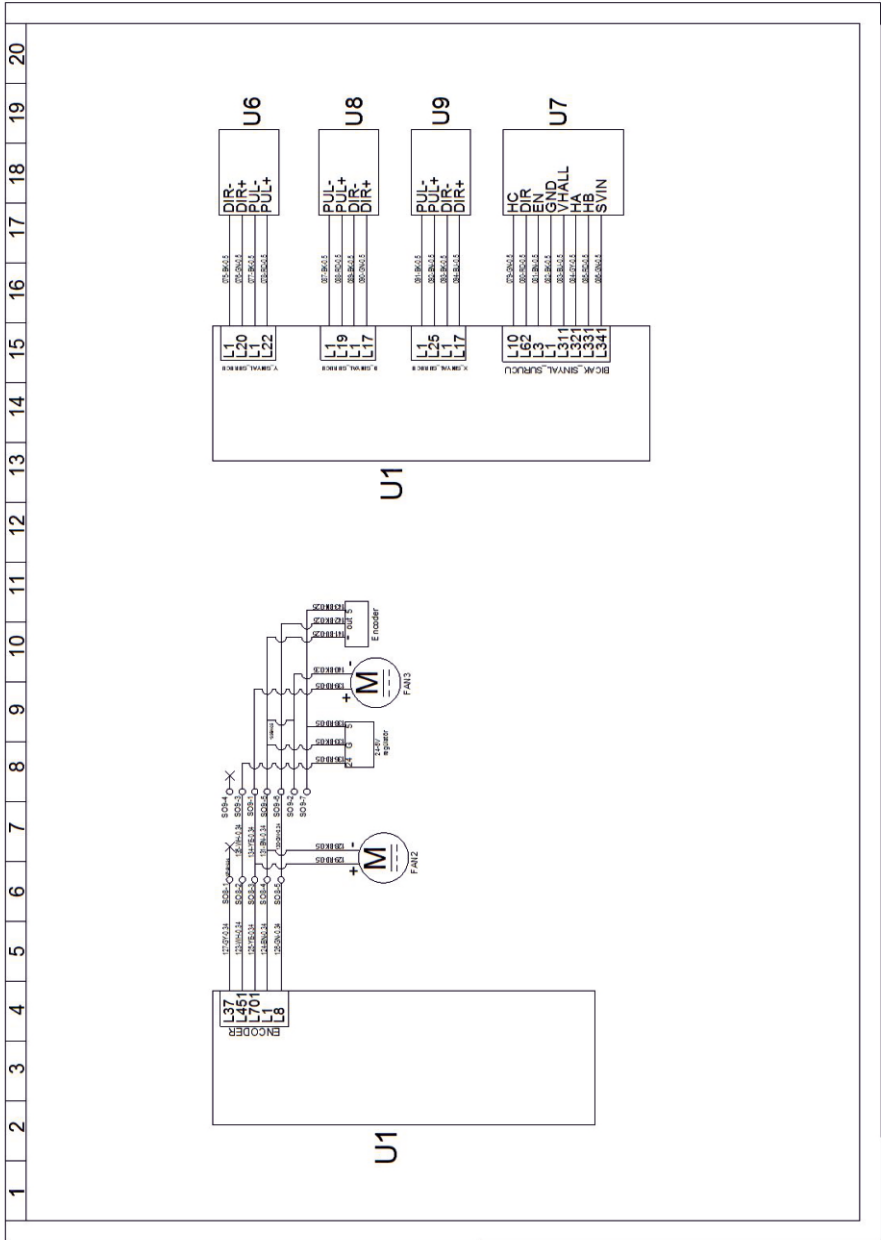

10. ADDITIONAL
10.1 Circuit Diagrams - DSUB 37

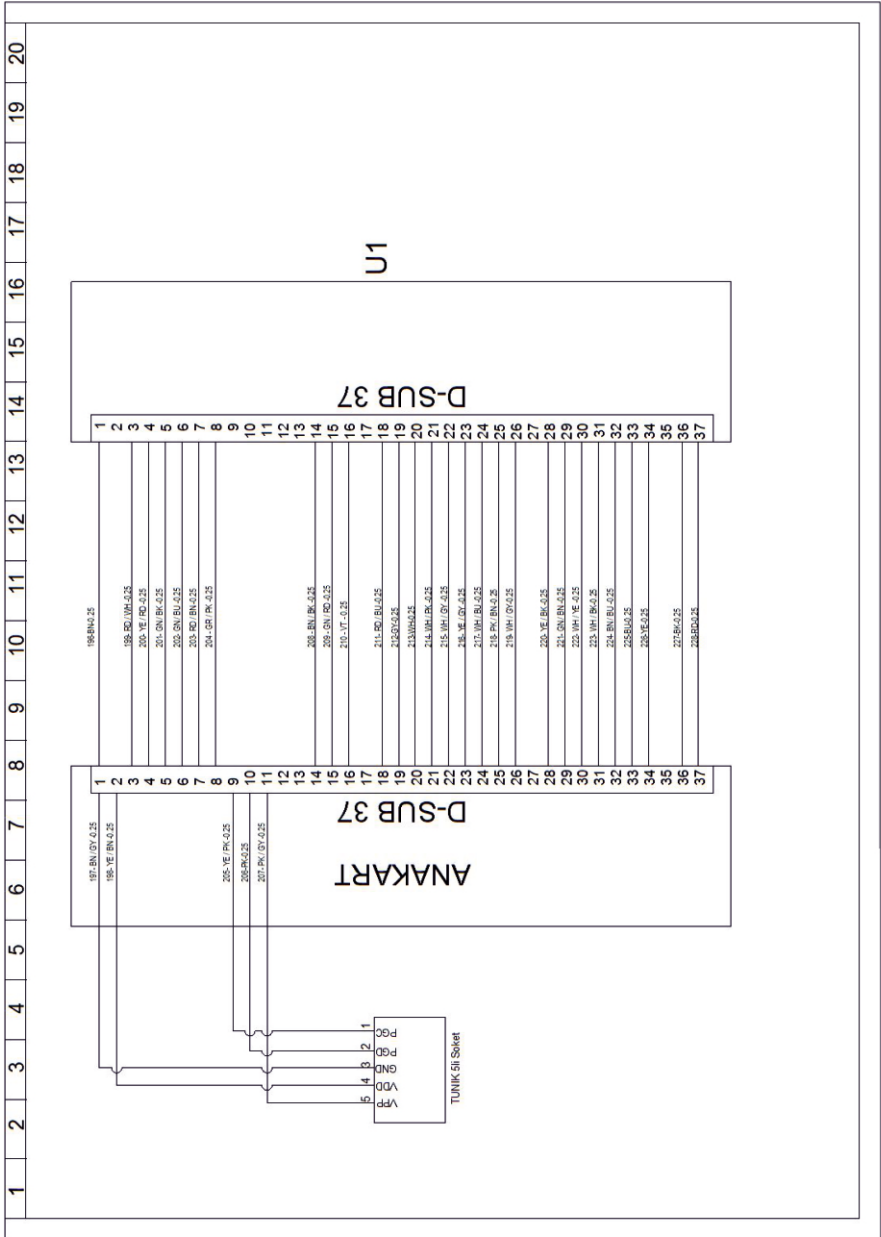

10. ADDITIONAL

10.1 Circuit Diagrams - Card, Relay and Potentiometer

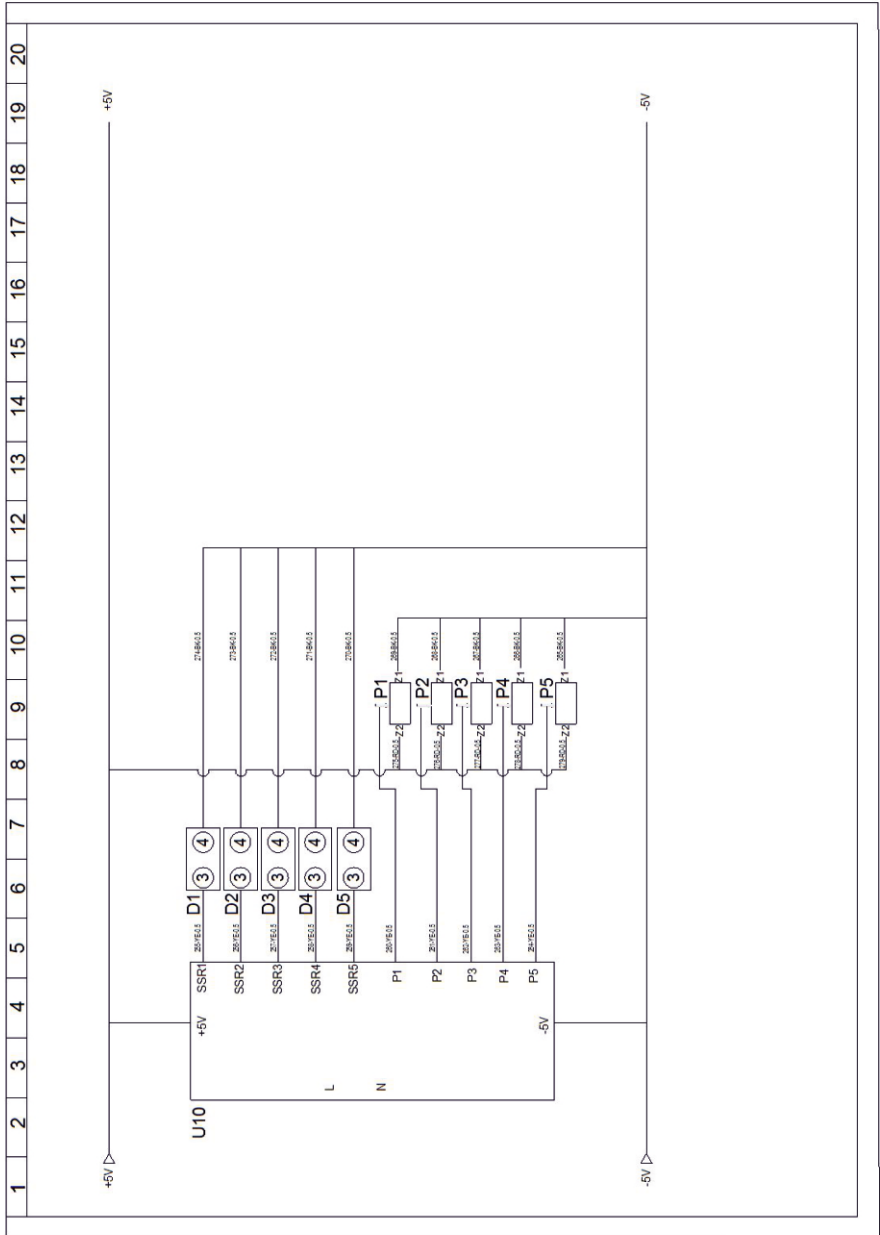

10. ADDITIONAL

10.1 Circuit Diagrams - Bainmarie 220 V Supply

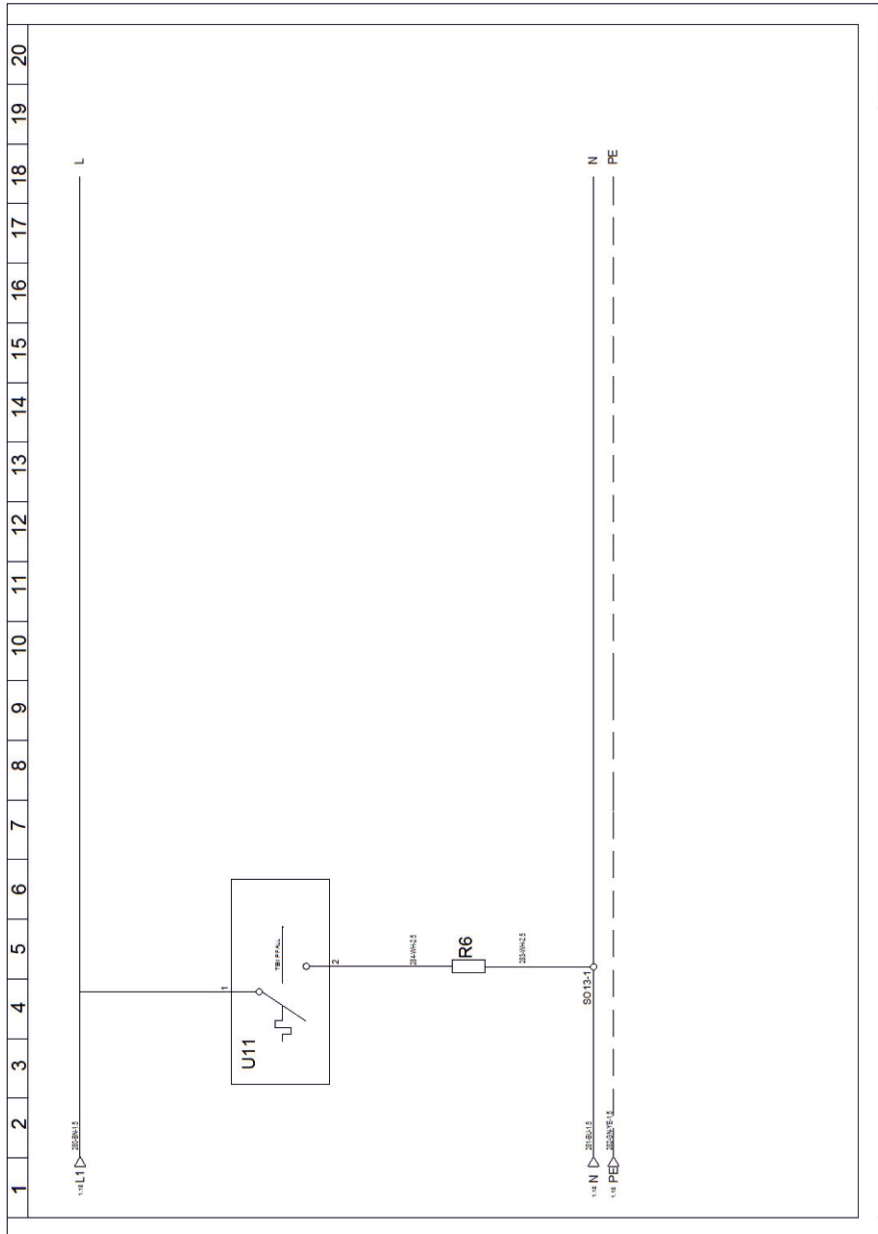

11. EXPLODED ASSEMBLY AND PARTS LIST

11.1 Part List Product Coding Selection Table

Detailed exploded assembly pictures of the parts used in the machines of Compact Series Doner Robots can be found on our next pages. Some parts of the robot are commonly used in the models. The table below is designed to help you select and identify the part you need. In this table, the top row is named according to the number of cooker radiant & resistance values of the products. In other words, if your robot has 4 eyes, it will make it easier to choose from which assembly page you want to look at the lines that start with 4 and the lines that start with 5 if you have 5 eyes. Common parts are expressed in the same colors. The description of the other expressions next to the number in the upper part of the line is as follows.

G - Gas Cooker Models

E - Electric Cooker Models

DK - Narrow Cut Head Models

GK - Wide Cut Head Models

SN - Product Parts & Assembly List Table Number Number Indication

PM - Parts & Assembly Codes in These Tables

P - Single Parts Letter Coding System at the Beginning of the Codes

M - Letter Coding System at the Beginning of the Codes of

Assembly Groups Constituted by Multiple Parts

Robot Department	4G-DK	4G-GK	4E-DK	4E-GK	5G-DK	5G-GK	5E-DK	5E-GK
Robot Part Code	M014135	M014144	M015142	M015743	M014141	M014143	M015744	M015745
X Axis	M012435	M012435	M012435	M012435	M009175	M009175	M009175	M009175
Y Axis	M011631	M011631	M011631	M011631	M011361	M011361	M011361	M011361
Arm Narrow Cut	M012108	X	M012108	X	M012108	X	M012108	X
Arm Wide Cut	X	M012519	X	M012519	X	M012519	X	M012519
Tray & Bain Marie	M012450	M012450	M012450	M012450	M012450	M012450	M012450	M012450
Cooker	M011600	M011600	M014767	M014767	M011491	M011491	M014045	M014045
Skewer Square	M012175	M012175	M012175	M012175	M000821	M000821	M000821	M000821
Skewer Edge	M013074	M013074	M013074	M013074	M012176	M012176	M012176	M012176
Plate	P023612	P023612	P023612	P023612	P023612	P023612	P023612	P023612
Table	M014465	M014465	M014465	M014465	M014465	M014465	M014465	M014465



WARNING!!!

The codes in the table above have been created for easy identification of your part or product code on the following pages. Our exploded assembly pages contain the coding system of the products. The manufacturer is not responsible for any inaccuracies caused by selection.

11. EXPLODED ASSEMBLY AND PARTS LIST

11.2 M014135 - ADR-C1-4G Narrow Cutting - Compact Series Robot

M014135

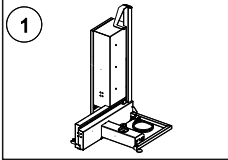

M012435

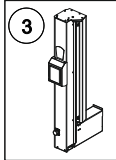

M011631

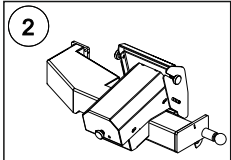

M012108

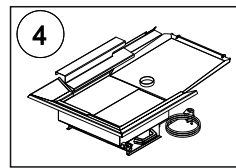
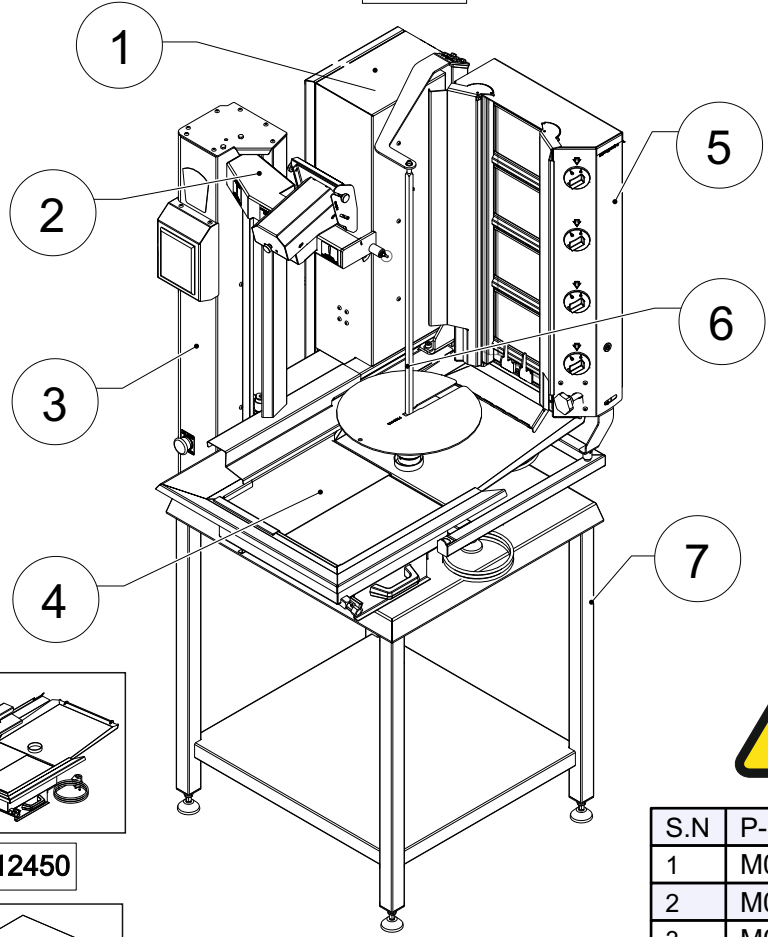

M012450

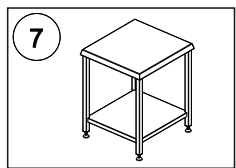

M014465

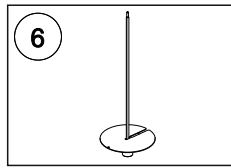

M012175

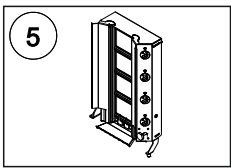

M011600



S.N	P-M Code
1	M012435
2	M012108
3	M011631
4	M012450
5	M011600
6	M012175
7	M014465

11. EXPLODED ASSEMBLY AND PARTS LIST

11.3 M015142 - DRAT4E Narrow Cutting - Compact Series Robot

M015142

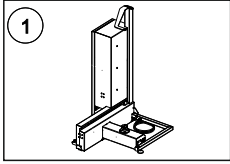

M012435

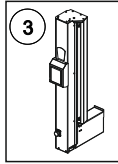

M011631

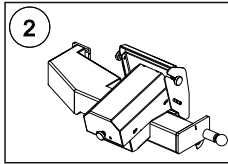

M012108

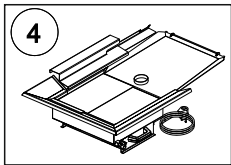
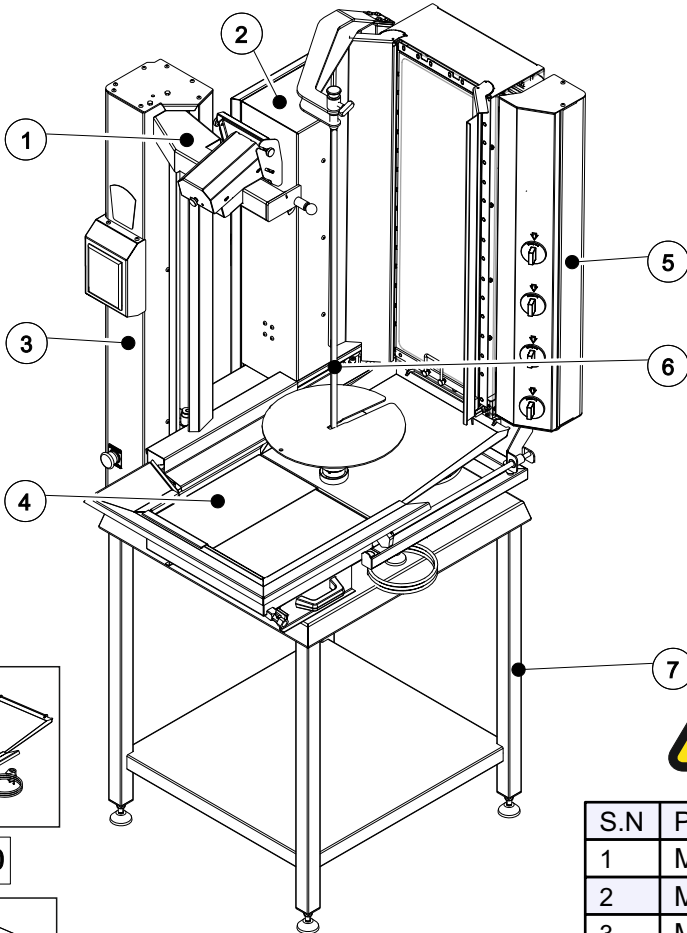

M012450

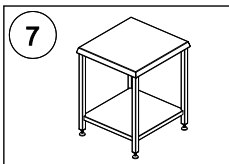

M014465

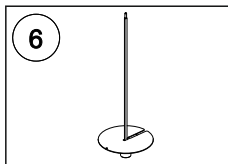

M012175

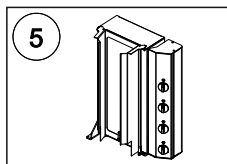

M014767



S.N	P-M Code
1	M012435
2	M012108
3	M011631
4	M012450
5	M014767
6	M012175
7	M014465

11. EXPLODED ASSEMBLY AND PARTS LIST

11.4 M014144 - ADR-C1-4G Wide Cutting - Compact Series Robot

M014144

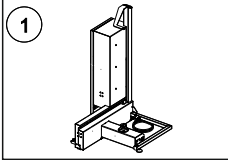

M012435

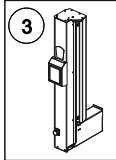

M011631

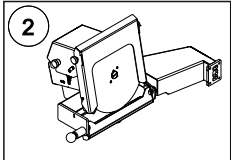

M012519

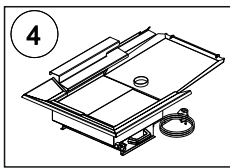
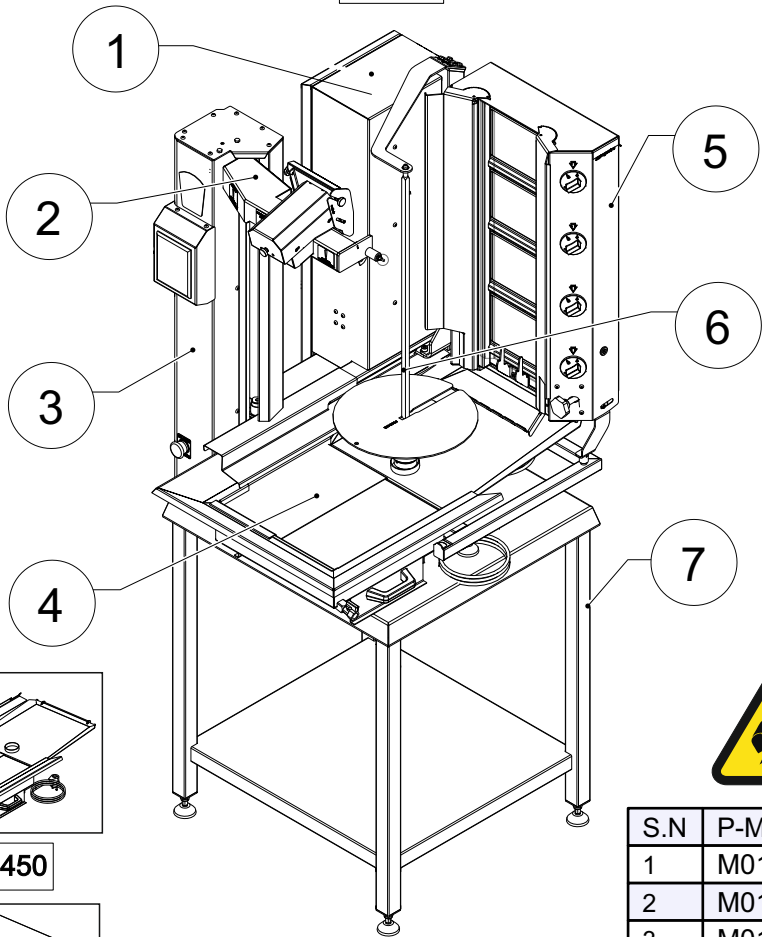

M012450

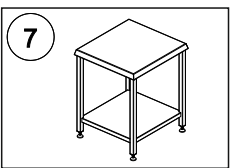

M014465

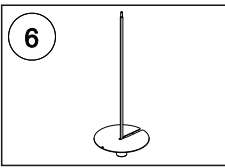

M012175

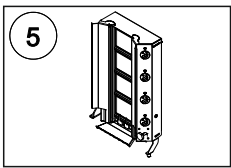

M011600



S.N	P-M Code
1	M012435
2	M012519
3	M011631
4	M012450
5	M011600
6	M012175
7	M014465

11. EXPLODED ASSEMBLY AND PARTS LIST
11.5 M015143 - DRAT4E Wide Cutting - Compact Series Robot

M015143

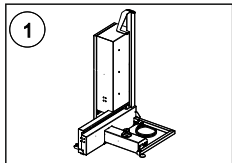

M012435

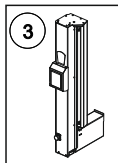

M011631

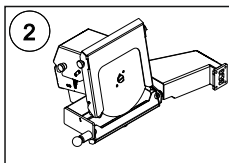

M012519

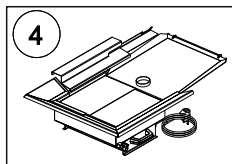
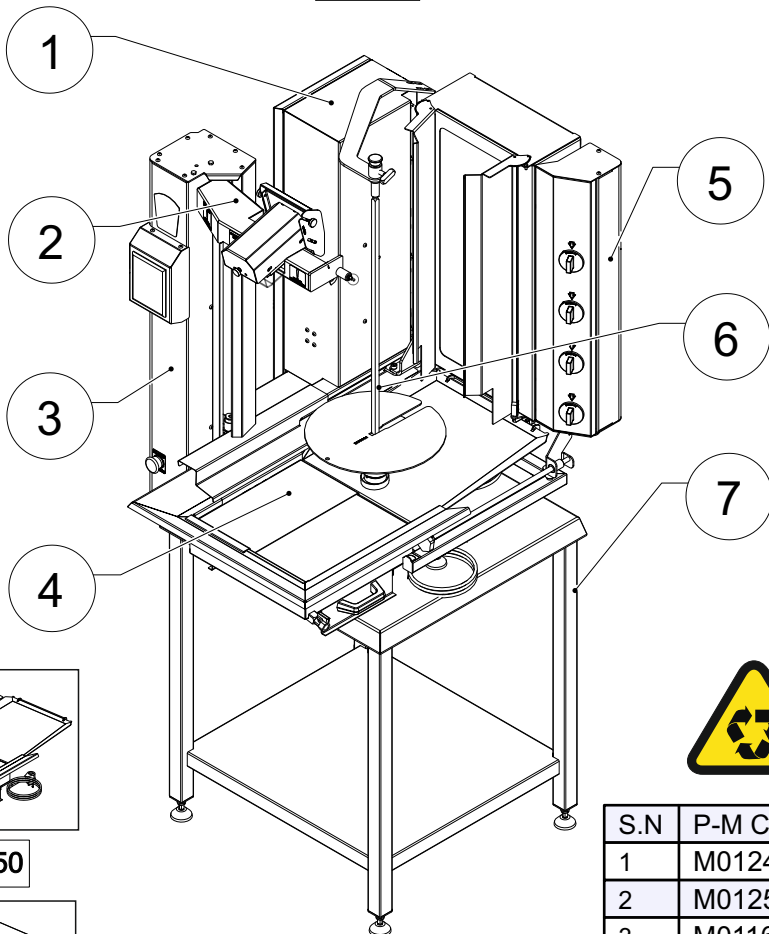

M012450

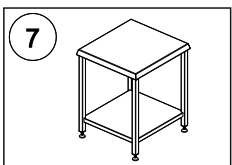

M014465

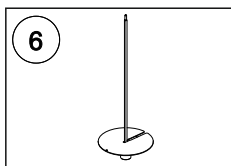

M012175

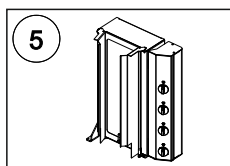

M014767



S.N	P-M Code
1	M012435
2	M012519
3	M011631
4	M012450
5	M014767
6	M012175
7	M014465

11. EXPLODED ASSEMBLY AND PARTS LIST

11.6 M014141 - ADR-C1-5G Narrow Cutting - Compact Series Robot

M014141

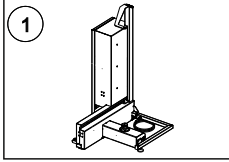

M009175

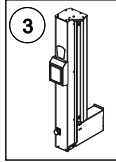

M011361

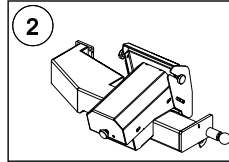

M012108

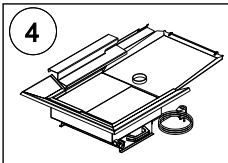
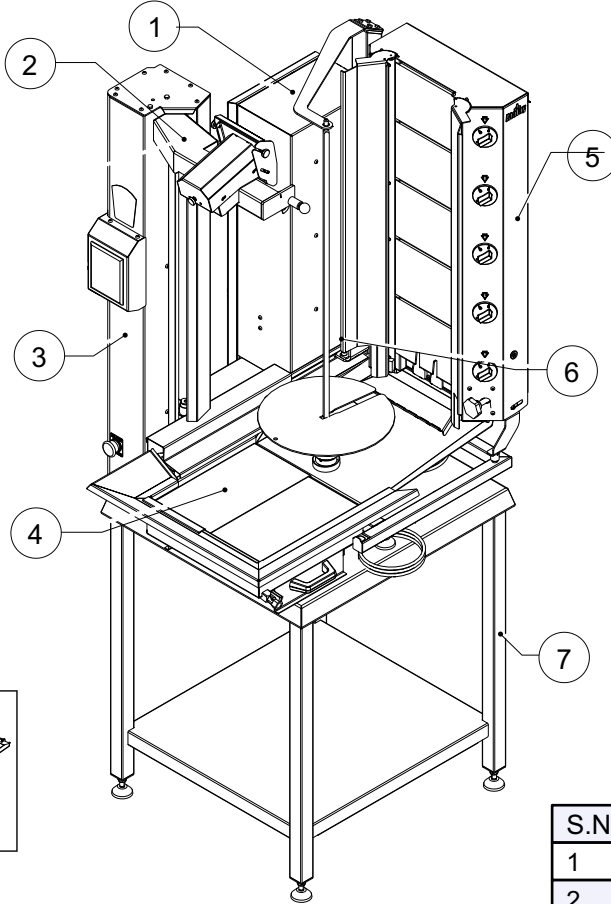

M012450

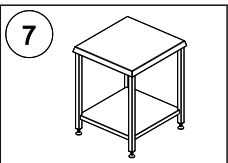

M014465

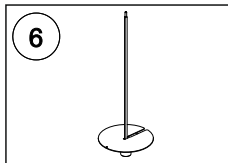

M000821

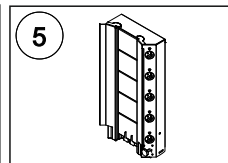

M011491



S.N	P-M Code
1	M009175
2	M012108
3	M011361
4	M012450
5	M011491
6	M000821
7	M014465

11. EXPLODED ASSEMBLY AND PARTS LIST
11.7 M015744- DRAT5E Narrow Cutting - Compact Series Robot

M015744

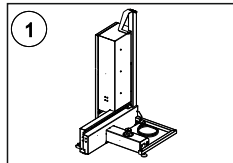

M009175

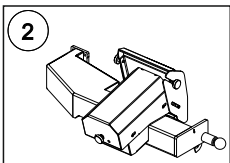

M012108

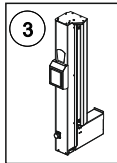

M011361

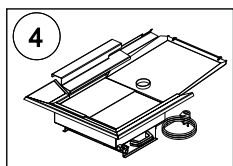
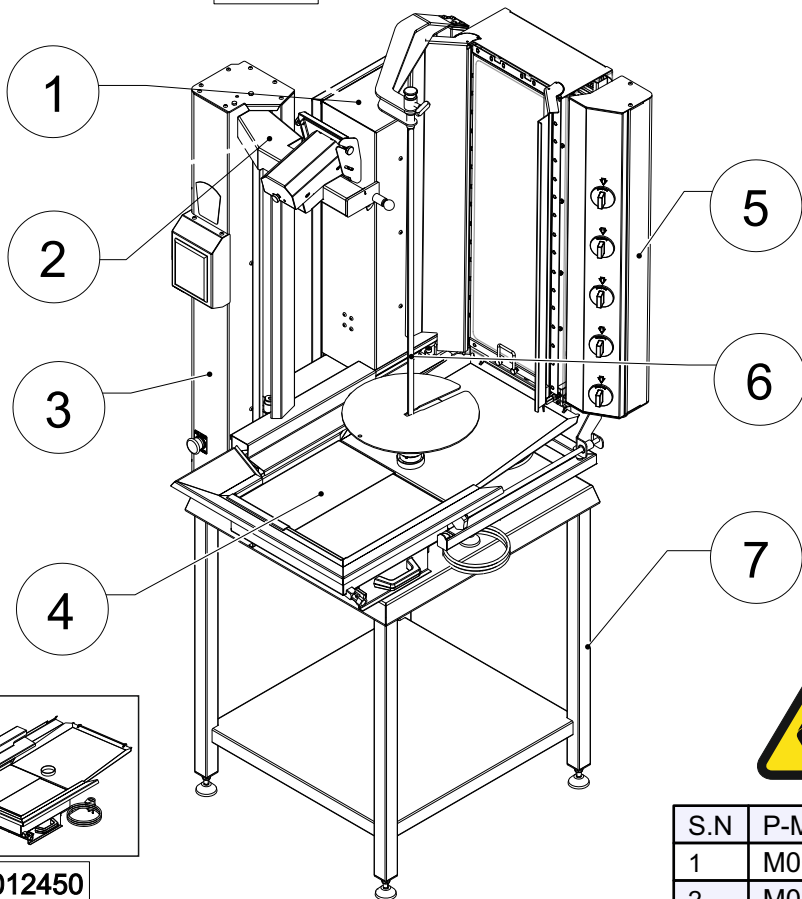

M012450

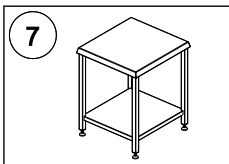

M014465

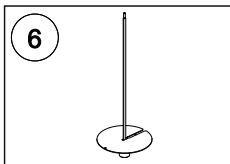

M000821

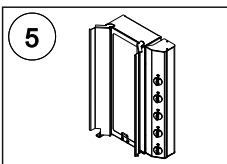

M014045



S.N	P-M Code
1	M009175
2	M012108
3	M011361
4	M012450
5	M014045
6	M000821
7	M014465

11. EXPLODED ASSEMBLY AND PARTS LIST

11.8 M014143 - ADR-C1-5G Wide Cutting - Compact Series Robot

M014143

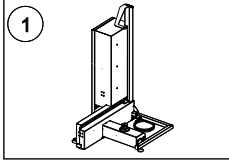

M009175

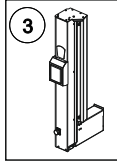

M011361

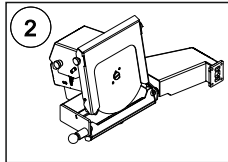

M012519

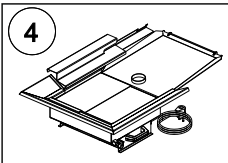
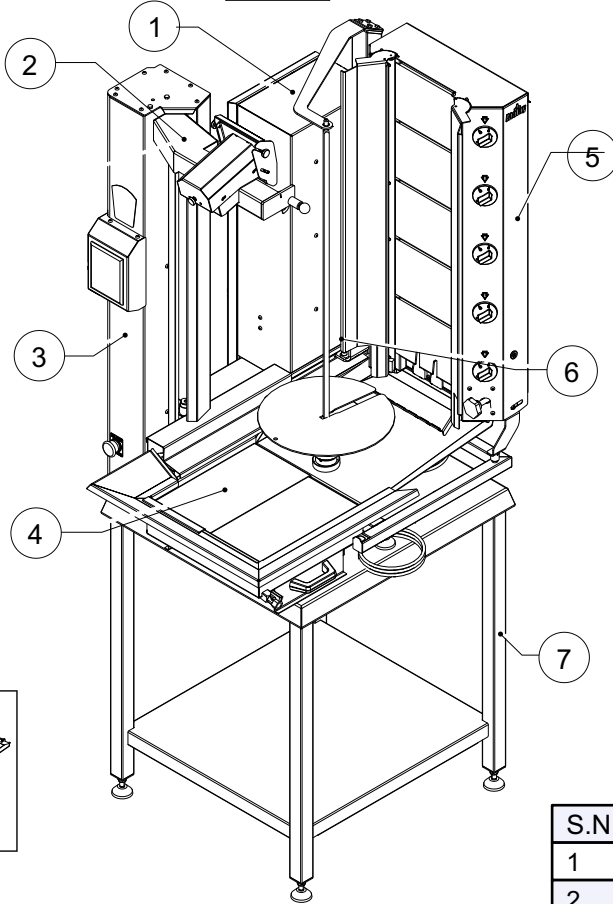

M012450

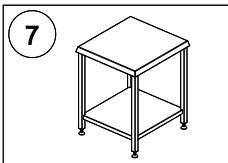

M014465

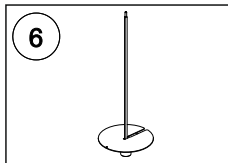

M000821

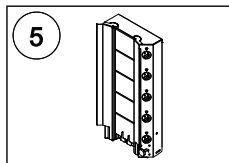

M011491



S.N	P-M Code
1	M009175
2	M012519
3	M011361
4	M012450
5	M011491
6	M000821
7	M014465

11. EXPLODED ASSEMBLY AND PARTS LIST

11.9 M015745- DRAT5E Wide Cutting - Compact Series Robot

M015745

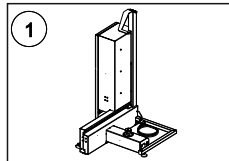

M009175

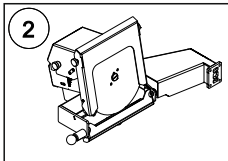

M012519

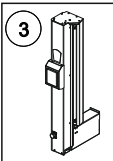

M011361

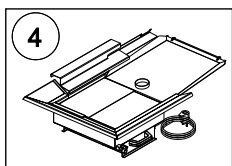
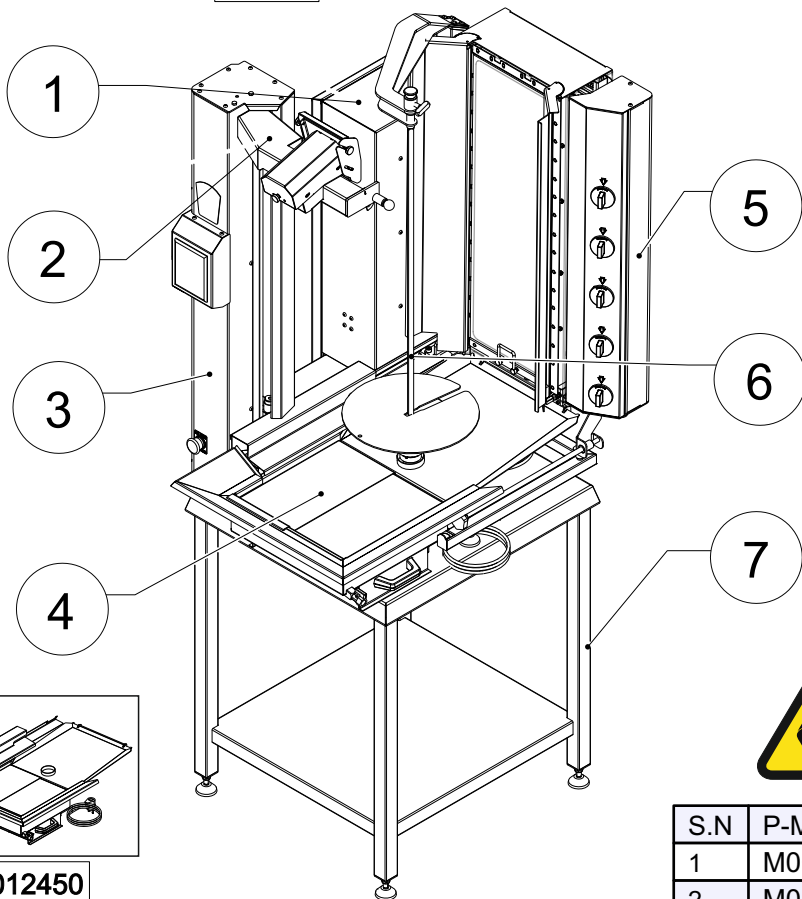

M012450

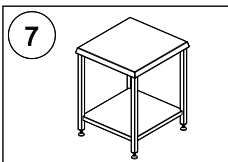

M014465

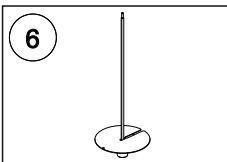

M000821

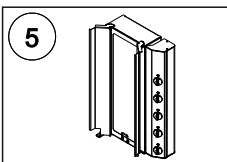

M014045



S.N	P-M Code
1	M009175
2	M012519
3	M011361
4	M012450
5	M014045
6	M000821
7	M014465

11. EXPLODED ASSEMBLY AND PARTS LIST

11.10 M009175 - DRAT5E - X Axis, Power Control Panel and Skewer Rotation Axis

1

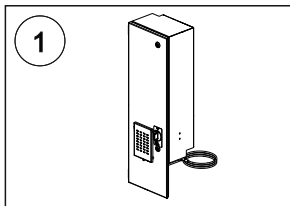

1

M01146

M009175

2

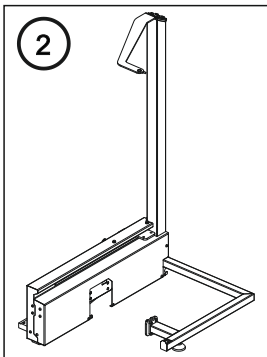

M017080

1

2

3

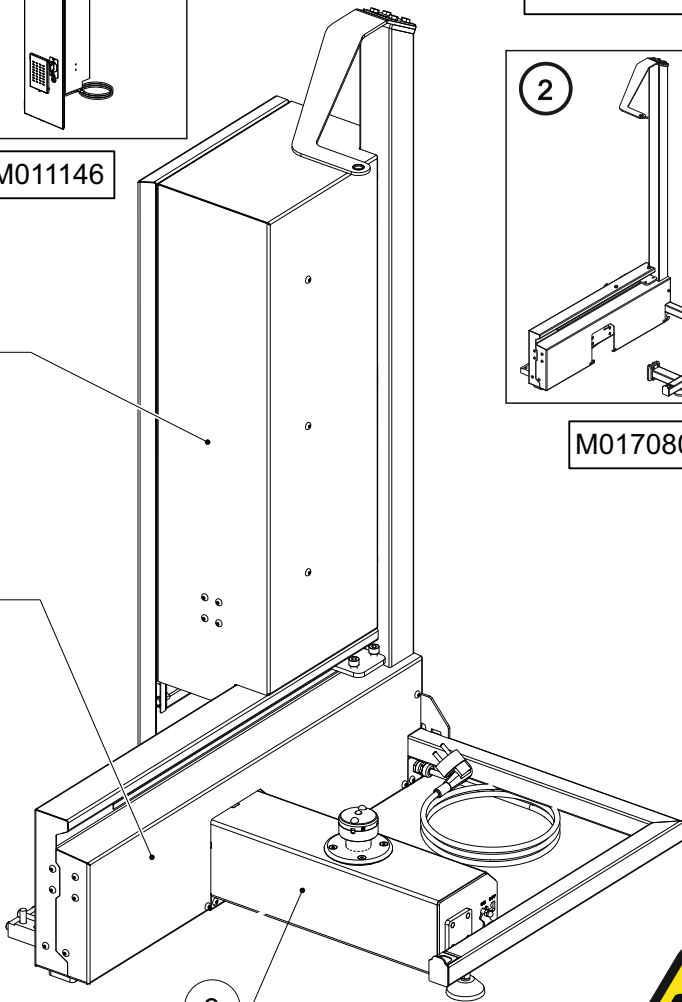

3

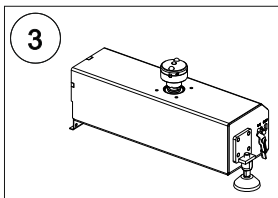

M010432



S.N	P-M Code
1	M01146
2	M017080
3	M010432

11. EXPLODED ASSEMBLY AND PARTS LIST
11.11 M011146 - DRAT5E - Power Control Panel

S.N	P-M Code
1	P066132
2	P007514
3	P034653
4	P009086
5	P026639
6	P026642
7	P024786
8	P024343
9	P013387
10	P024356
11	P002296
12	P024280
13	P041616
14	P006670
15	P040068
16	P002305
17	P034372

1

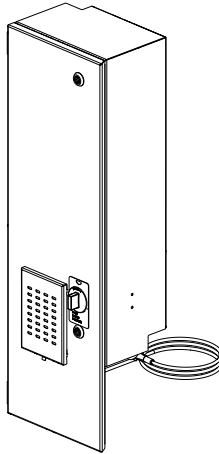

M011146

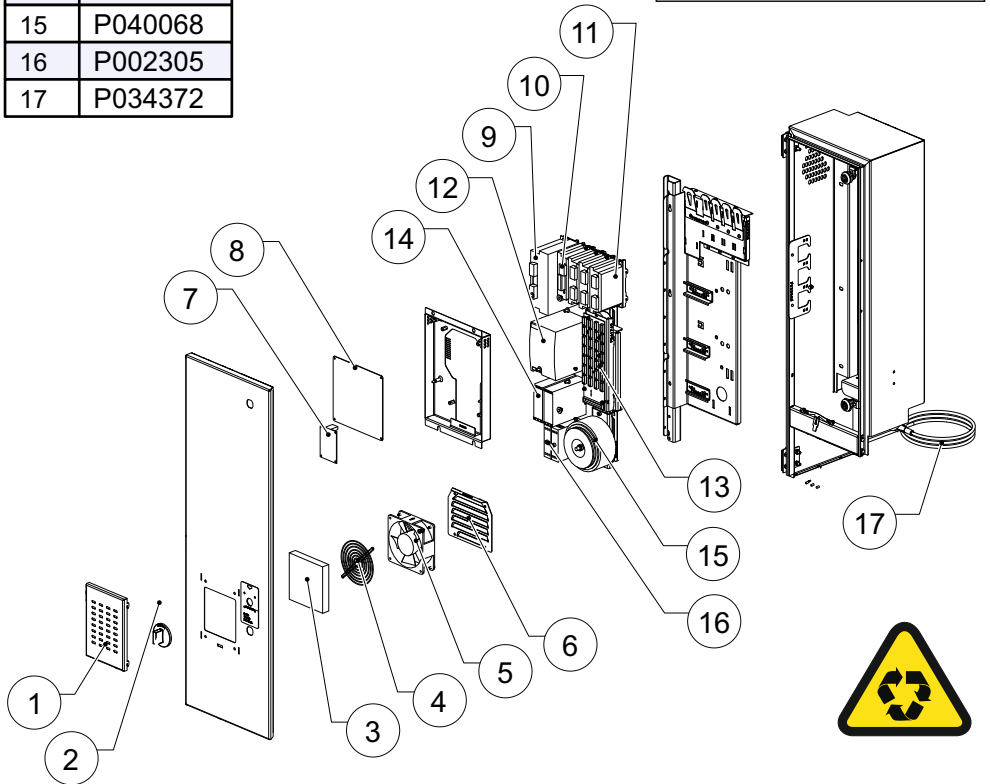
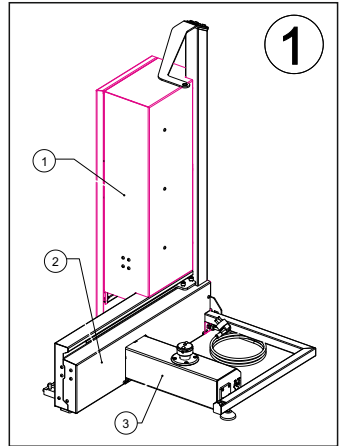

11. EXPLODED ASSEMBLY AND PARTS LIST
11.12 M017080-1 - DRAT5E - X Axis

1 M017080 - 1

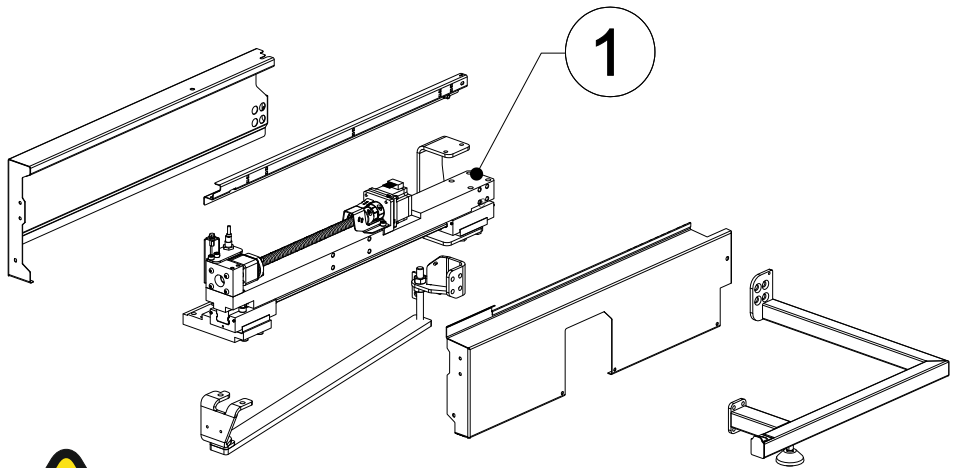
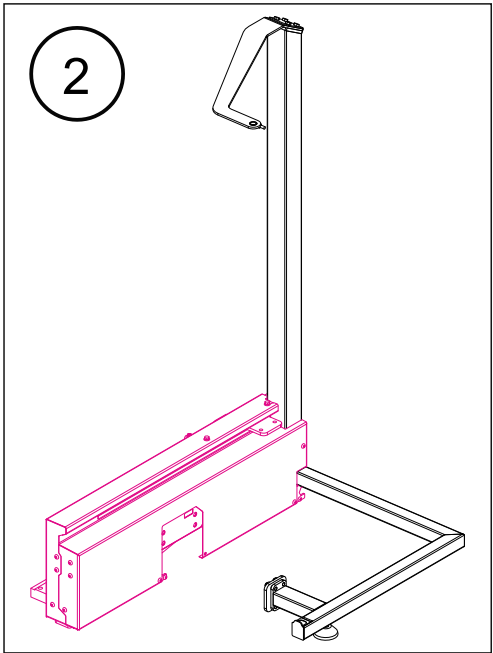

11. EXPLODED ASSEMBLY AND PARTS LIST
11.13 M017080-2 - DRAT5E - X Axis > Detail

M017080-2

1

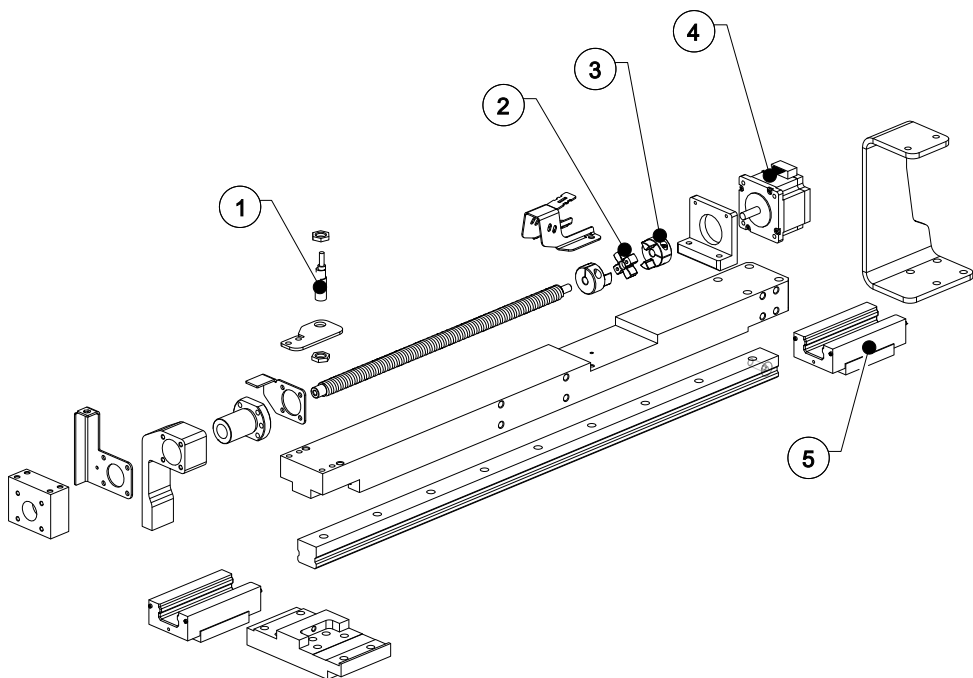

S.N	P-M Code
1	P021201
2	P002299
3	P002300
4	P002301
5	P018859

11. EXPLODED ASSEMBLY AND PARTS LIST
11.14 M010432 - DRAT5E - Skewer Rotation Axis

M010432

1

S.N	P-M Code	Quantity
1	P069001	1
2	P023197	1
3	P002300	1
4	P007252	1
5	P068616	1
6	P068650	1
7	P068651	1
8	P022086	1
9	M002913	1
10	P024054	1
11	P002332	1
12	P002014	1
13	P002331	1
14	P002330	1
15	P002299	1

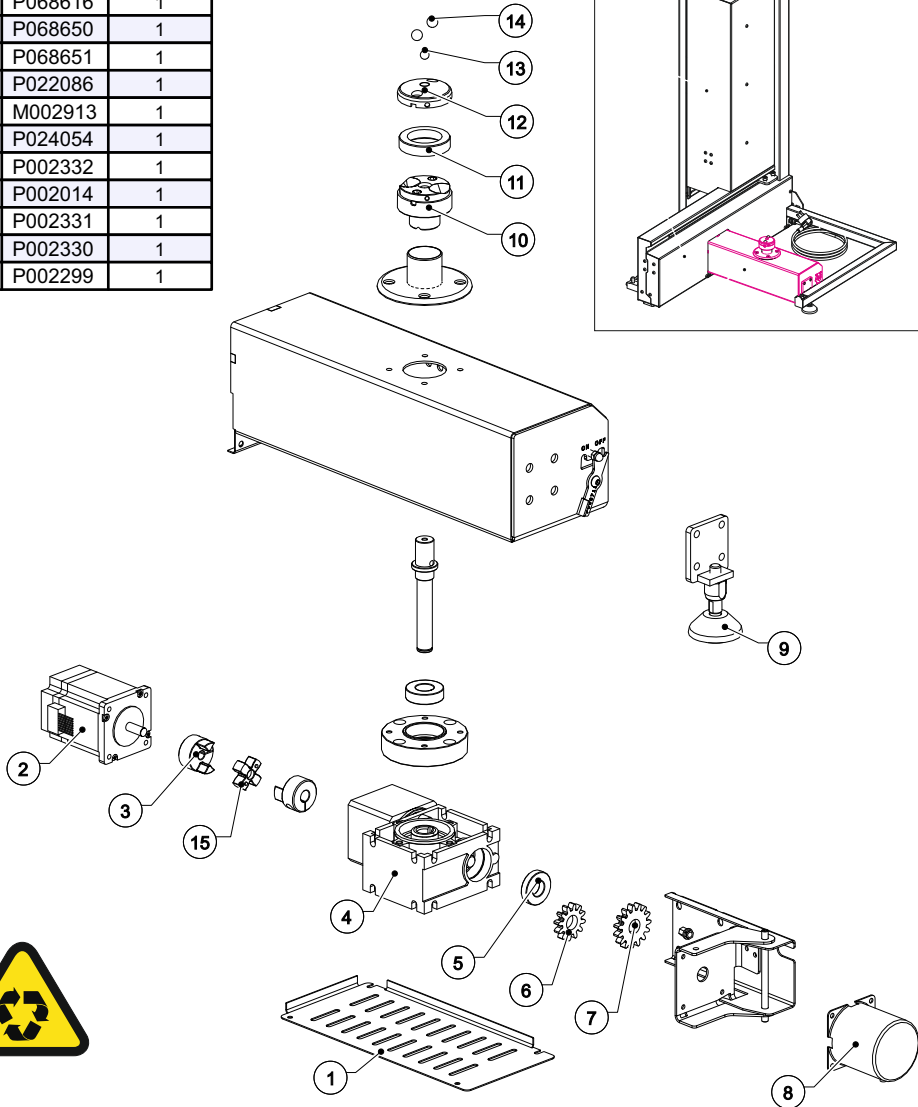
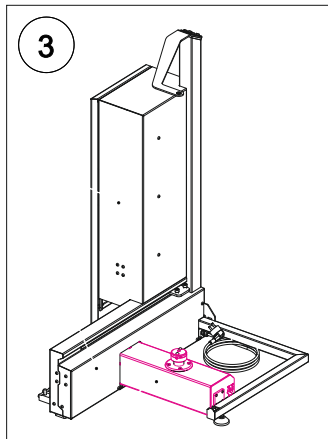

11. EXPLODED ASSEMBLY AND PARTS LIST

11.15 M009175-DRAT5E -X Axis, Power Control Panel and Skewer Rotation Axis

1

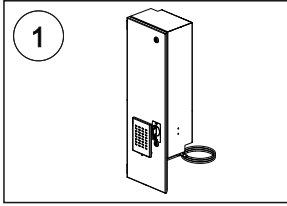

M011146

M012435

2

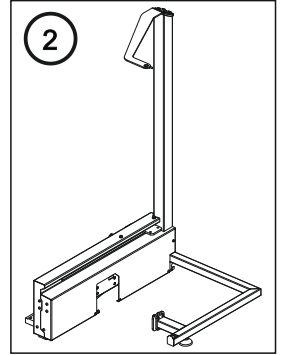

M017080

1

2

3

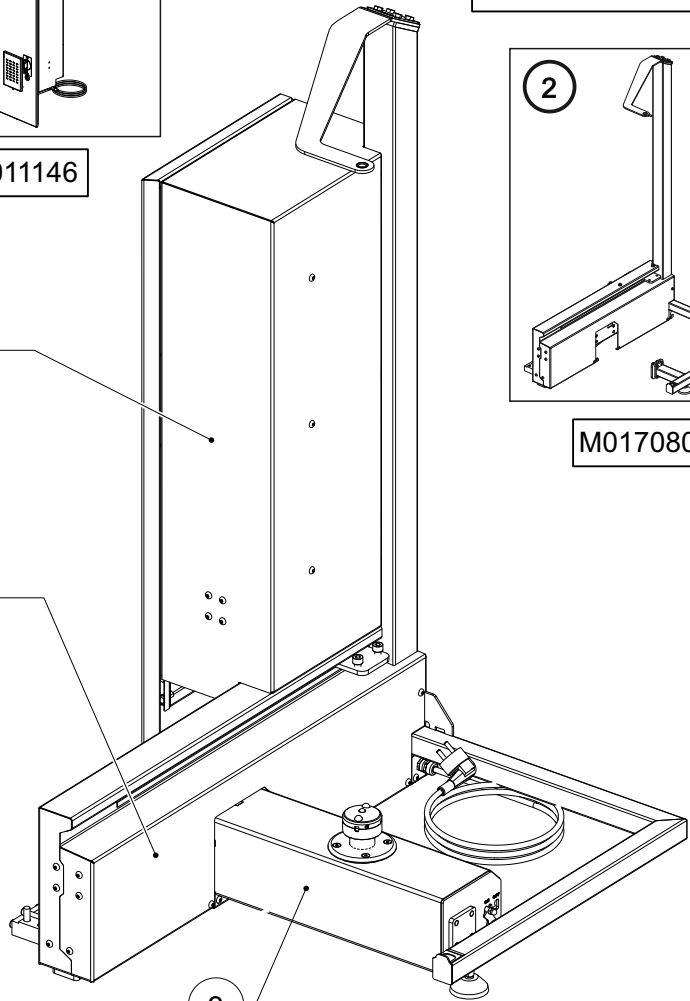

3

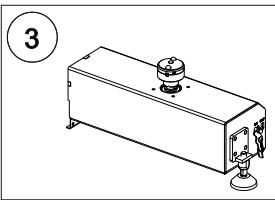

M010432



11. EXPLODED ASSEMBLY AND PARTS LIST
11.16 M011146 - DRAT5E - Power Control Panel

1

M011146

S.N	P-M Code
1	P066132
2	P007514
3	P034653
4	P009086
5	P026639
6	P026642
7	P024786
8	P024343
9	P013387
10	P024356
11	P002296
12	P024280
13	P041616
14	P006670
15	P040068
16	P002305
17	P034372

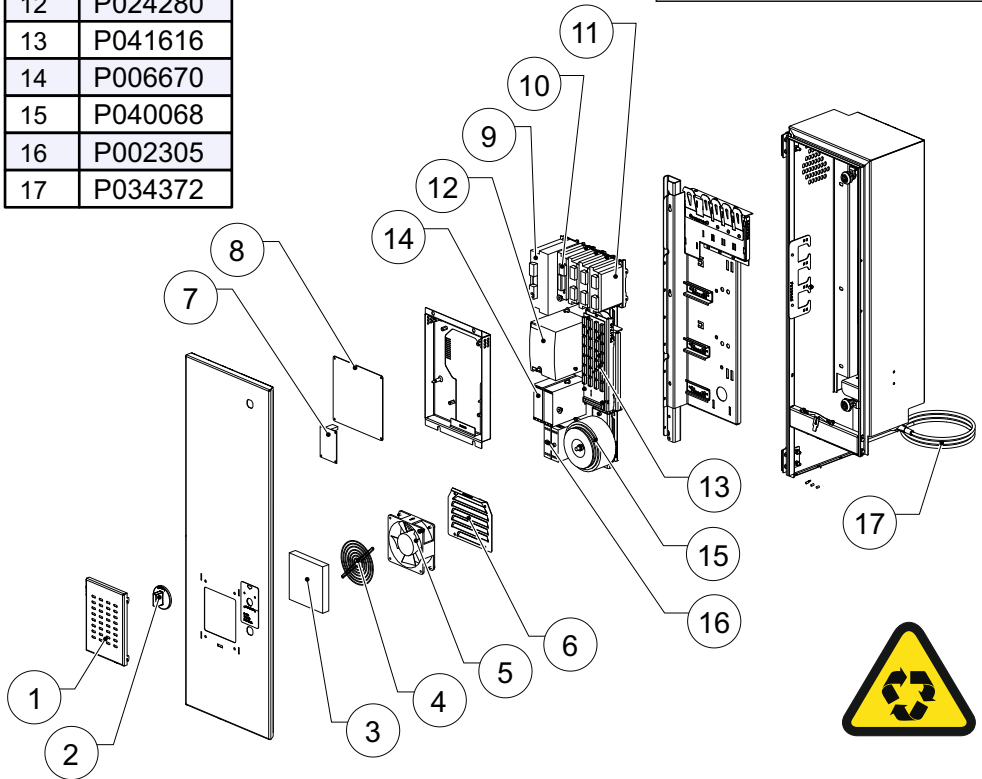
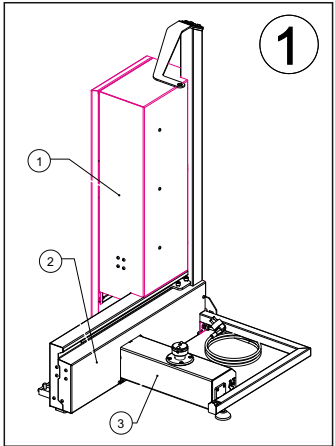

11. EXPLODED ASSEMBLY AND PARTS LIST
11.17 M017080-1 - DRAT5E - X Axis

1

M017080 - 1

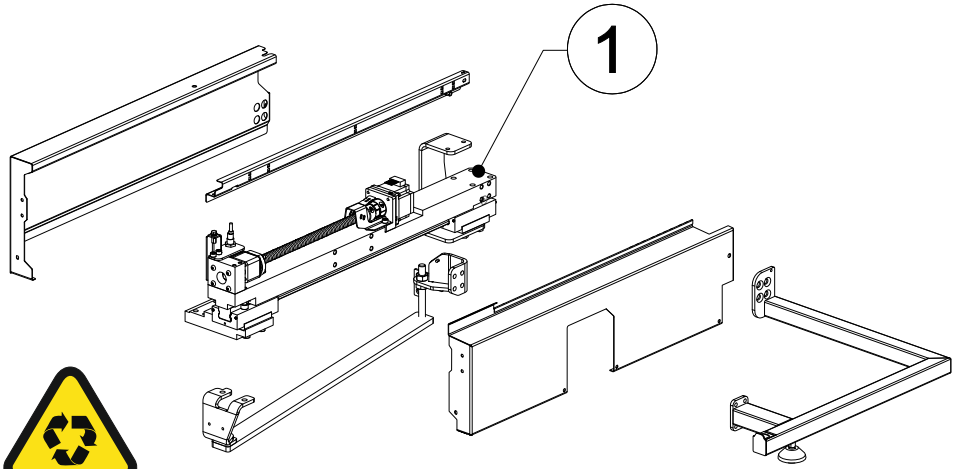
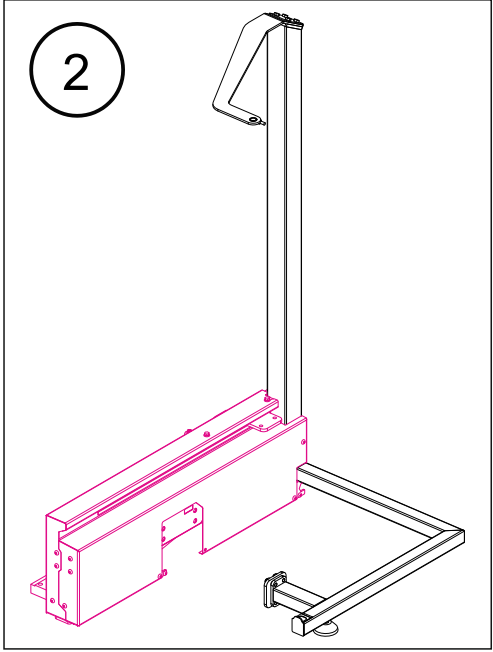

11. EXPLODED ASSEMBLY AND PARTS LIST
11.18 M017080-2 - DRAT5E - X Axis> Detail

M017080-2

1

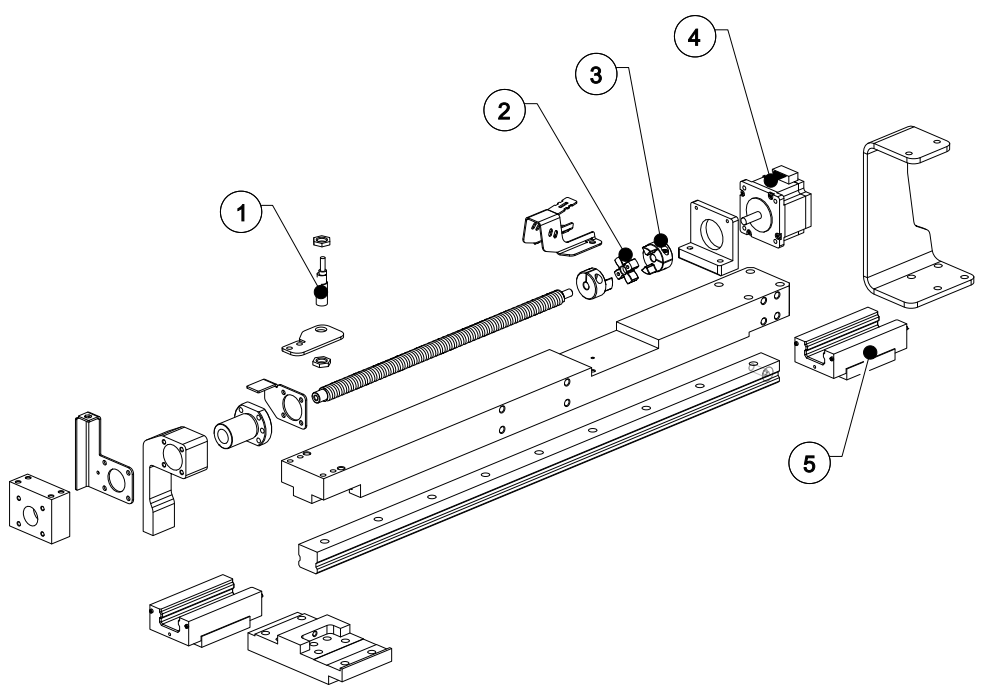

S.N	P-M Code
1	P021201
2	P002299
3	P002300
4	P002301
5	P018859



11. EXPLODED ASSEMBLY AND PARTS LIST
11.19 M010432 - - DRAT5E - Skewer Rotation Axis

M010432

1

S.N	P-M Code	Quantity
1	P069001	1
2	P023197	1
3	P002300	1
4	P007252	1
5	P068616	1
6	P068650	1
7	P068651	1
8	P022086	1
9	M002913	1
10	P024054	1
11	P002332	1
12	P002014	1
13	P002331	1
14	P002330	1
15	P002299	1

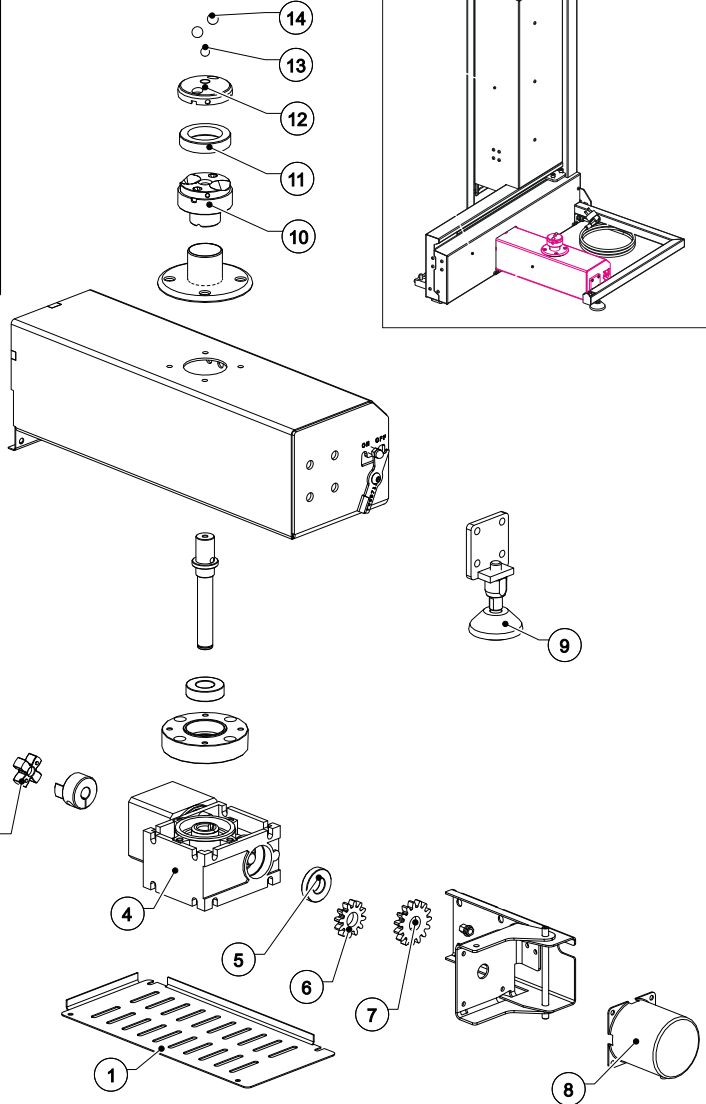
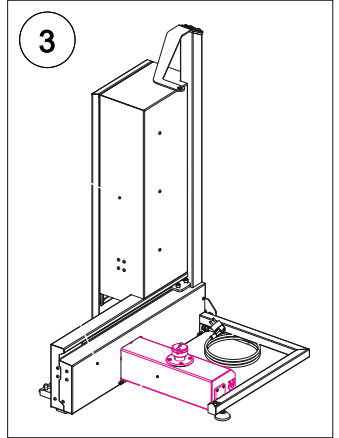

11. EXPLODED ASSEMBLY AND PARTS LIST
11.20 M012108 - DRAT5E - Narrow Cut Lever Unit - 1

M012108-1

S.N	P-M Code
1	P023937
2	P001897
3	P002368
4	P002374
5	P001894
6	M011181
7	P001895

2

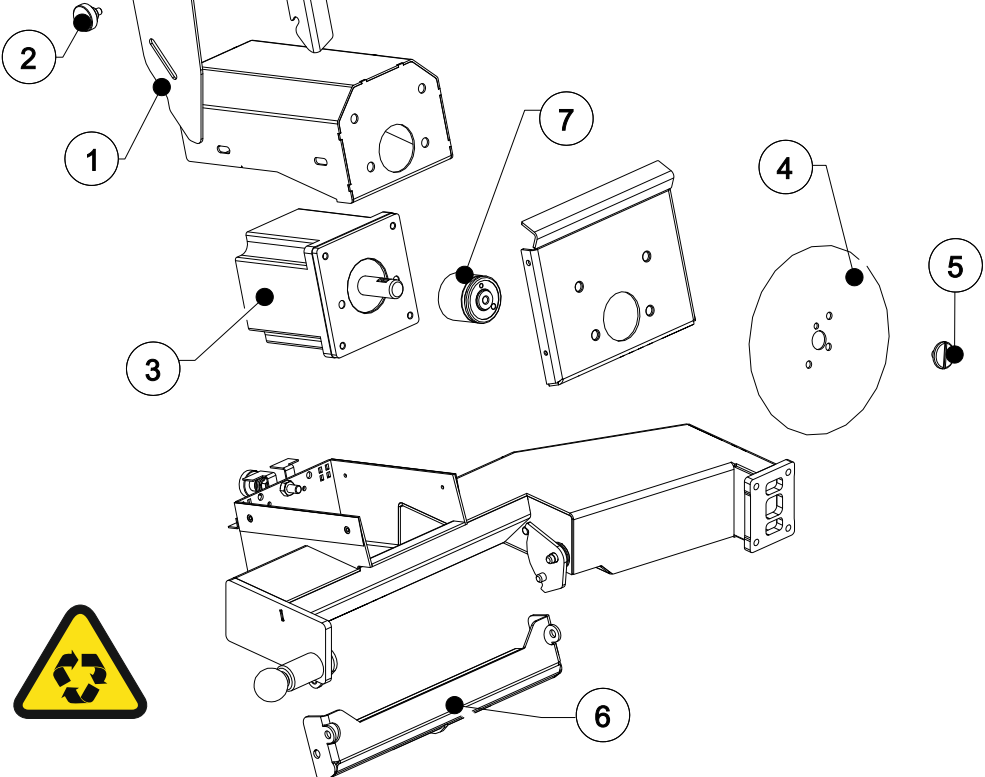
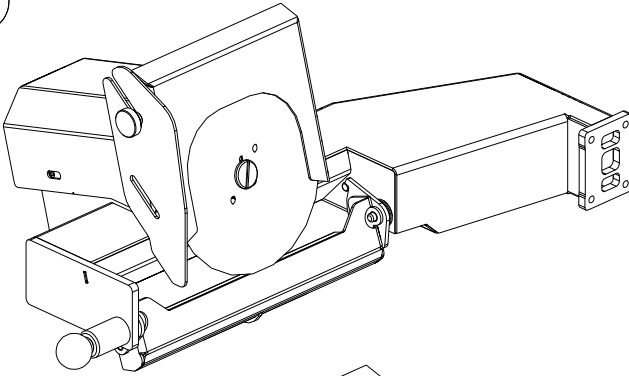

11. EXPLODED ASSEMBLY AND PARTS LIST
11.21 M012108 - DRAT5E - Narrow Cut Lever Unit - 2

M012108-2

2

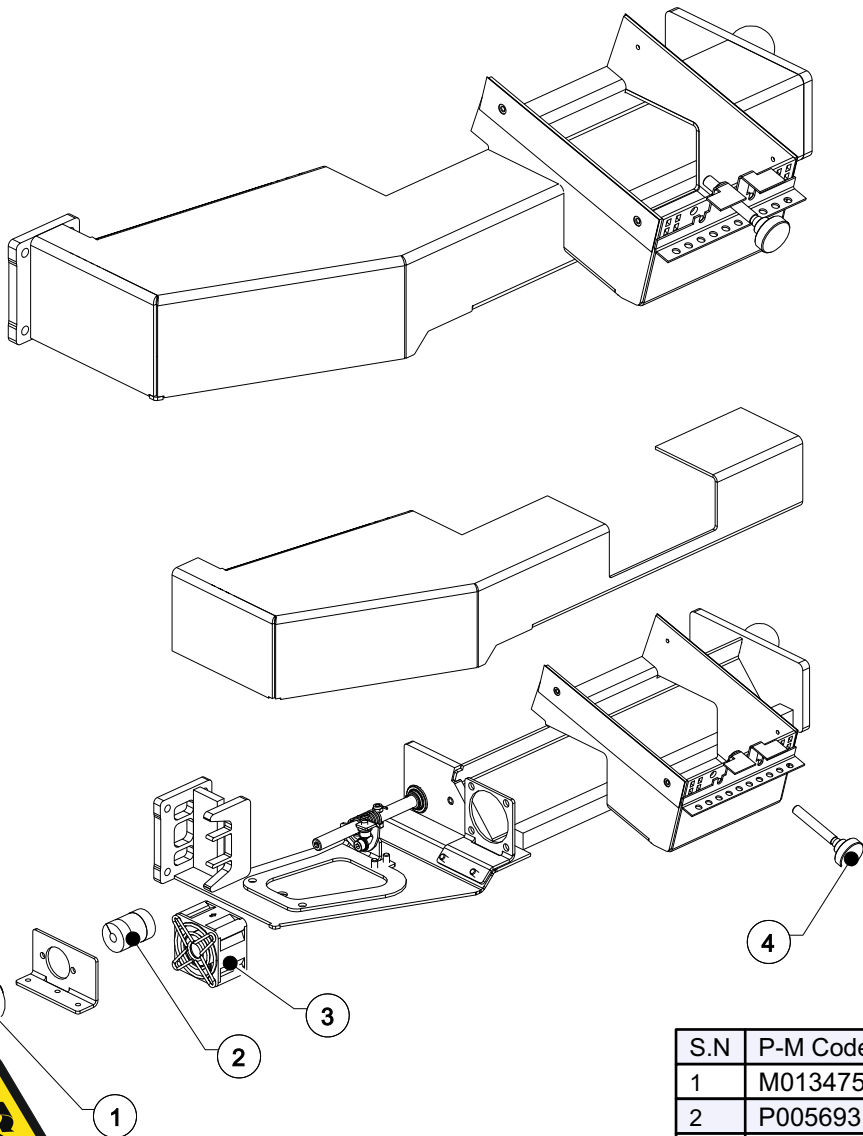

S.N	P-M Code
1	M013475
2	P005693
3	P028704
4	P001903

11. EXPLODED ASSEMBLY AND PARTS LIST

11.22 M012108 - DRAT5E - Wide Cut Cutting Arm Unit - 1

M012519-1

S.N	P-M Code
1	P001894
2	P008796
3	P001895
4	P002368
5	P001897

2

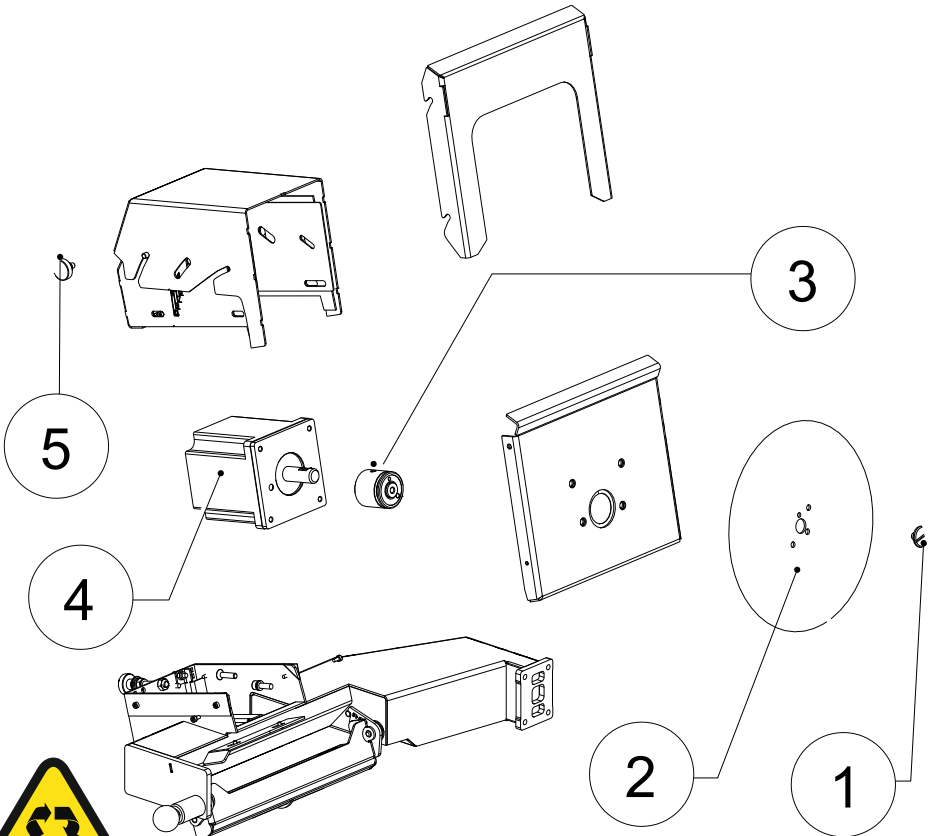
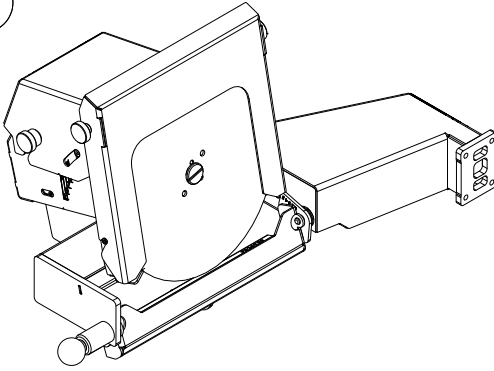

11. EXPLODED ASSEMBLY AND PARTS LIST
11.23 M012108 - DRAT5E - Wide Cut Cutting Arm Unit - 2

2

M012519-2

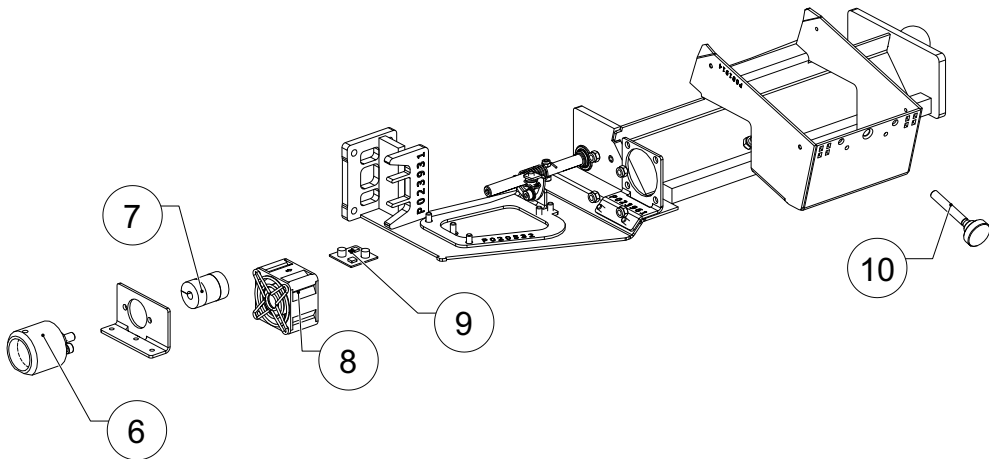
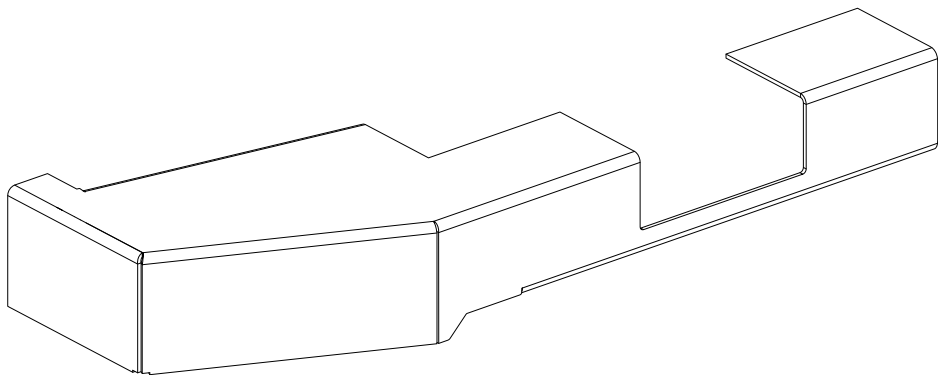

S.N	P-M Code
6	M013475
7	P020501
8	P028704
9	P063387
10	P001903

11. EXPLODED ASSEMBLY AND PARTS LIST
11.24 M011631 - DRAT5E - Y Axis - 1

M011631-1

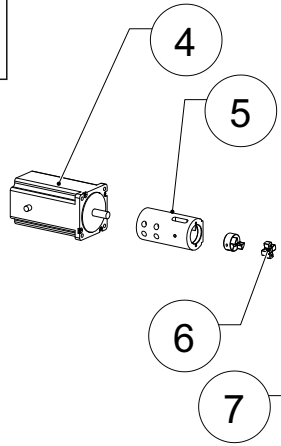
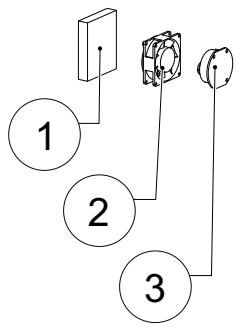
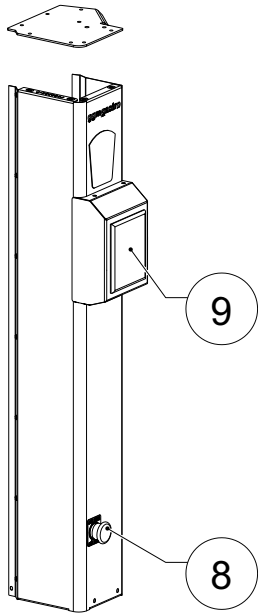
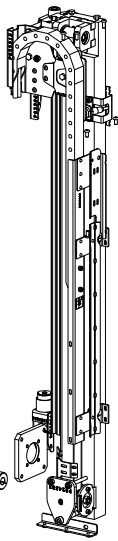
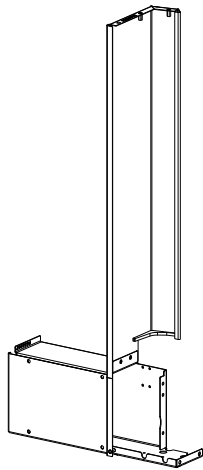
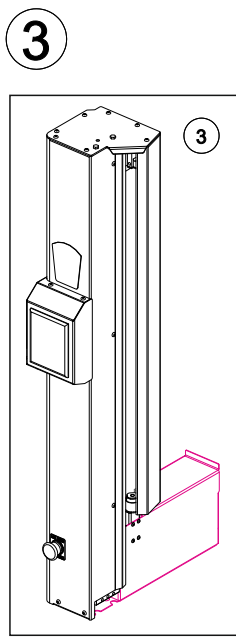

S.N	P-M Code
1	P013452
2	P013446
3	P017539
4	P019820
5	P019053
6	P032969
7	P003382
8	P002340
9	P023996

11. EXPLODED ASSEMBLY AND PARTS LIST
11.25 M011631 - DRAT5E - Y Axis - 2

3

M011631-2

S.N	P-M Code
1	P026925
2	P021201
3	P025666

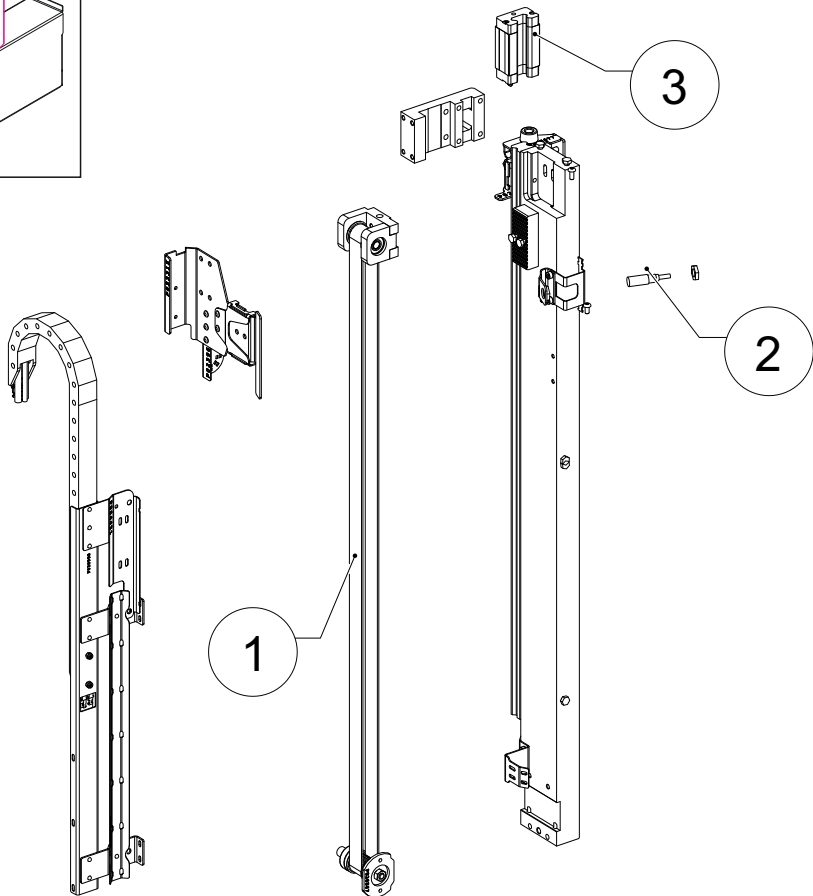
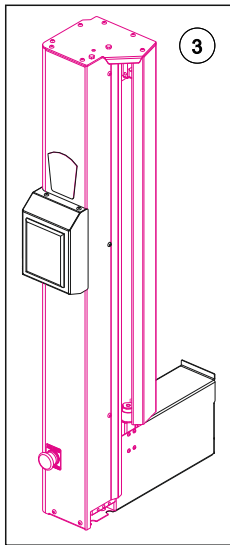

11. EXPLODED ASSEMBLY AND PARTS LIST
11.26 M011361 - DRAT5E - Y Axis - 1

M011361-1

S.N	P-M Code
1	P013446
2	P017539
3	P019820
4	P003382
5	P002299
6	P013446
7	P017539

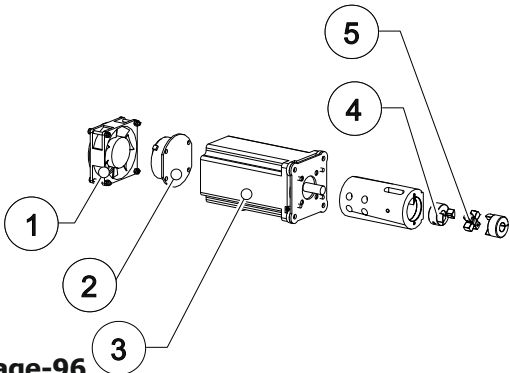
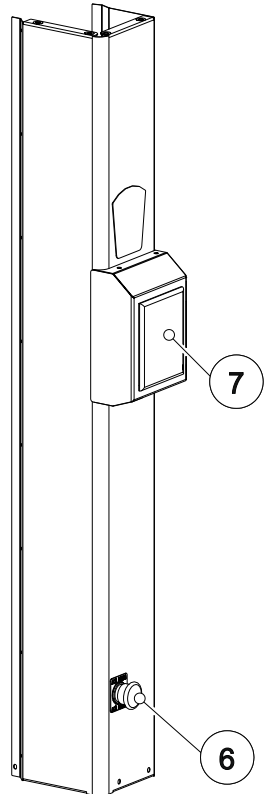
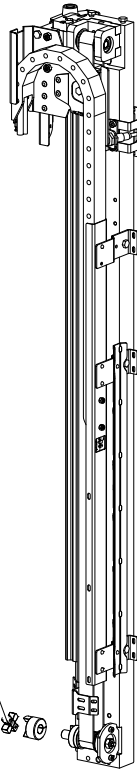
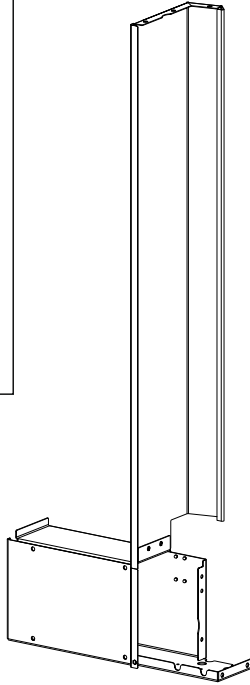
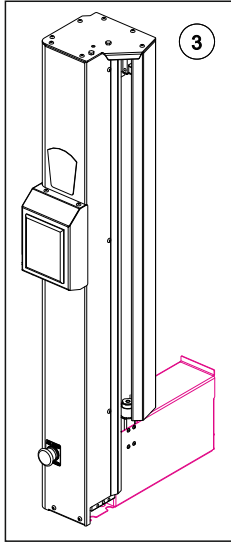

11. EXPLODED ASSEMBLY AND PARTS LIST
11.27 M011361 - DRAT5E - Y Axis - 2

M011361-2

3

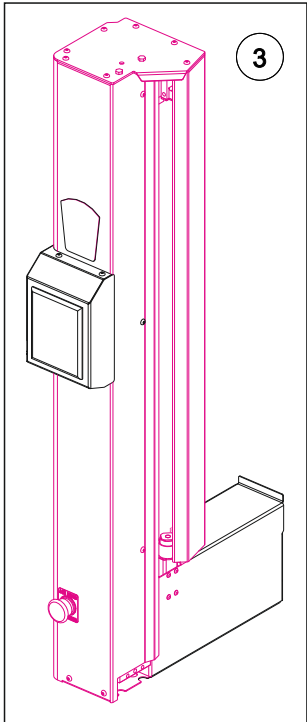
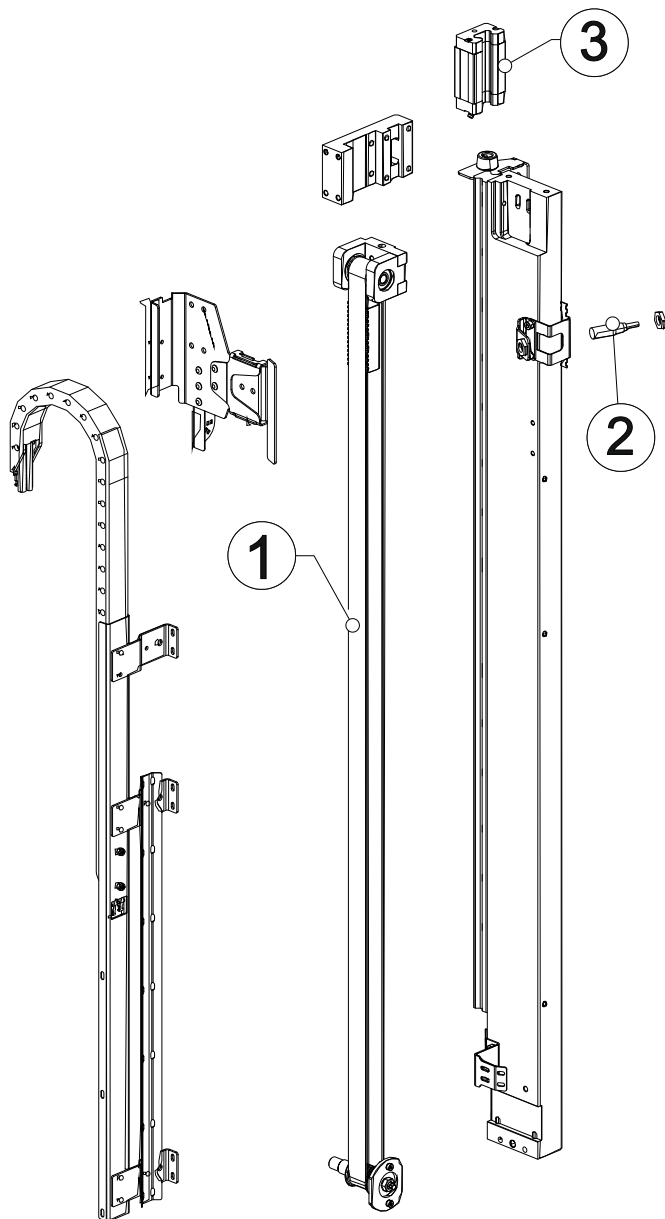

S.N	P-M Code
1	P020656
2	P021201
3	P025666



11. EXPLODED ASSEMBLY AND PARTS LIST
11.28 M012450 - DRAT5E - Tray & Bainmarie - 1

M012450-1

S.N	P-M Code
1	P032301
2	P028205
3	P023823
4	P032299
5	P032300
6	P032297
7	P032298
8	P032608
9	P029352
10	M010955

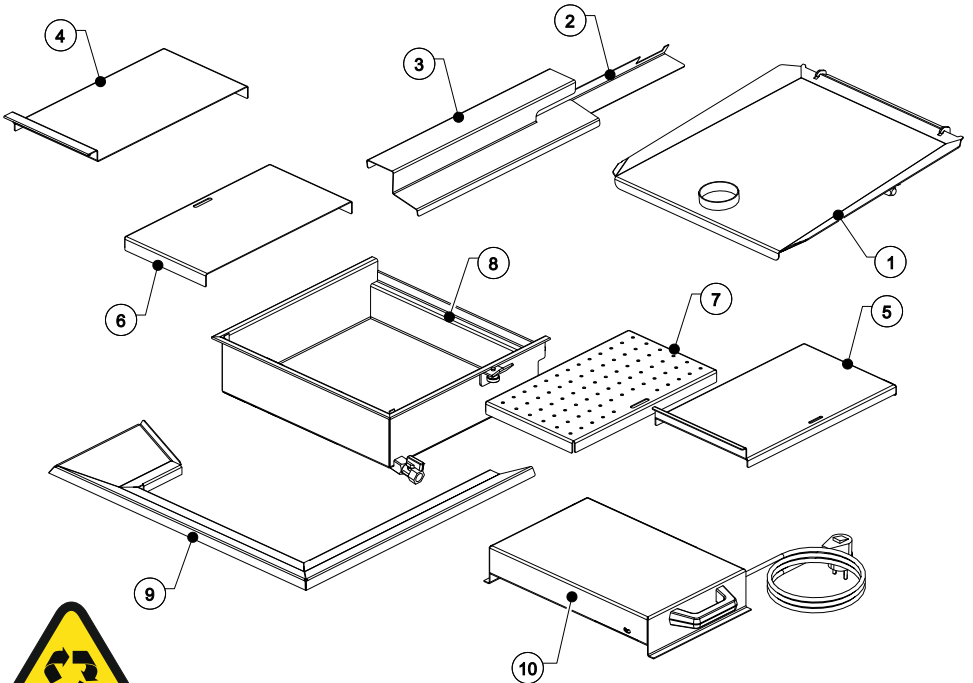
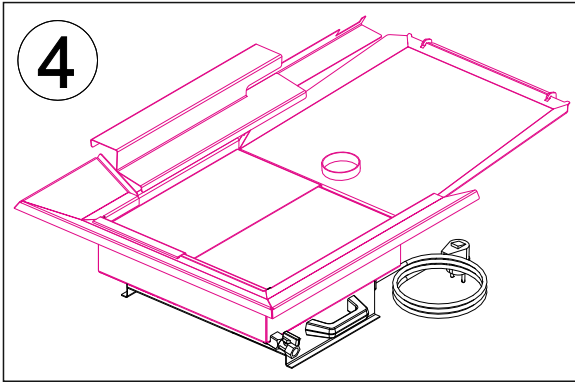

11. EXPLODED ASSEMBLY AND PARTS LIST
11.29 M012450 - DRAT5E - Tray & Bainmarie - 2

M012450-2

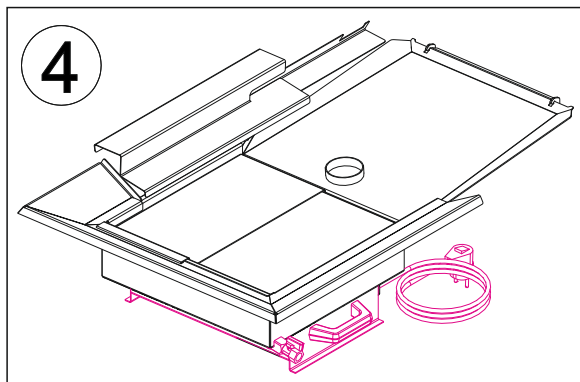

S.N	P-M Code
1	P033539
2	P012614

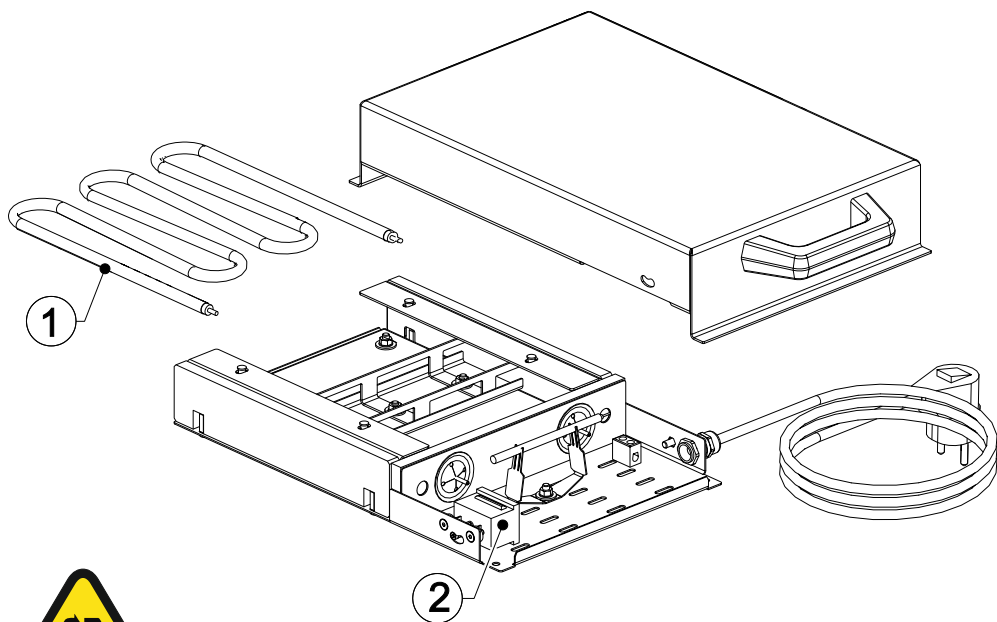

Warning!!!
The power supply line of your Doner Robot necessarily grounding in accordance with standards must be used with electrical installations!



11. EXPLODED ASSEMBLY AND PARTS LIST
11.30 M011600 - ADR-C1-4G - Gas Cooker

M011600

S.N	P-M Code
1	P033265
2	P033291
3	P031385
4	P001699
5	P018738
6	P000279
7	P031324
8	P024005

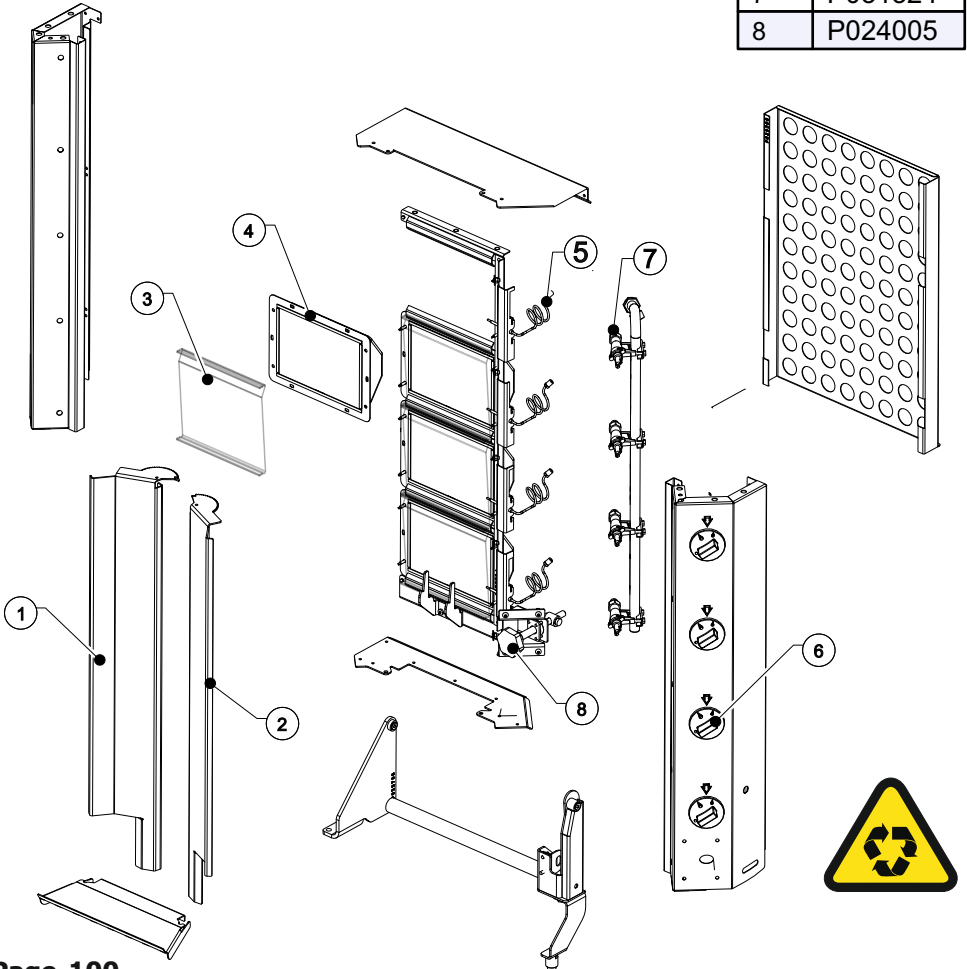
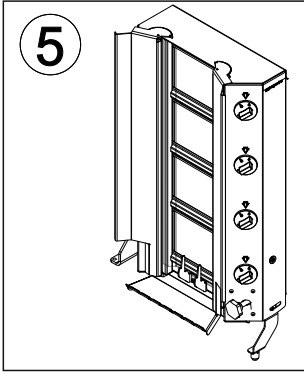

11. EXPLODED ASSEMBLY AND PARTS LIST
11.31 M011491 - ADR-C1-5G - Gas Cooker

M011491

S.N	P-M Code
1	P033245
2	P033306
3	P023954
4	P001699
5	P018738
6	P000279
7	P031324
8	P024005

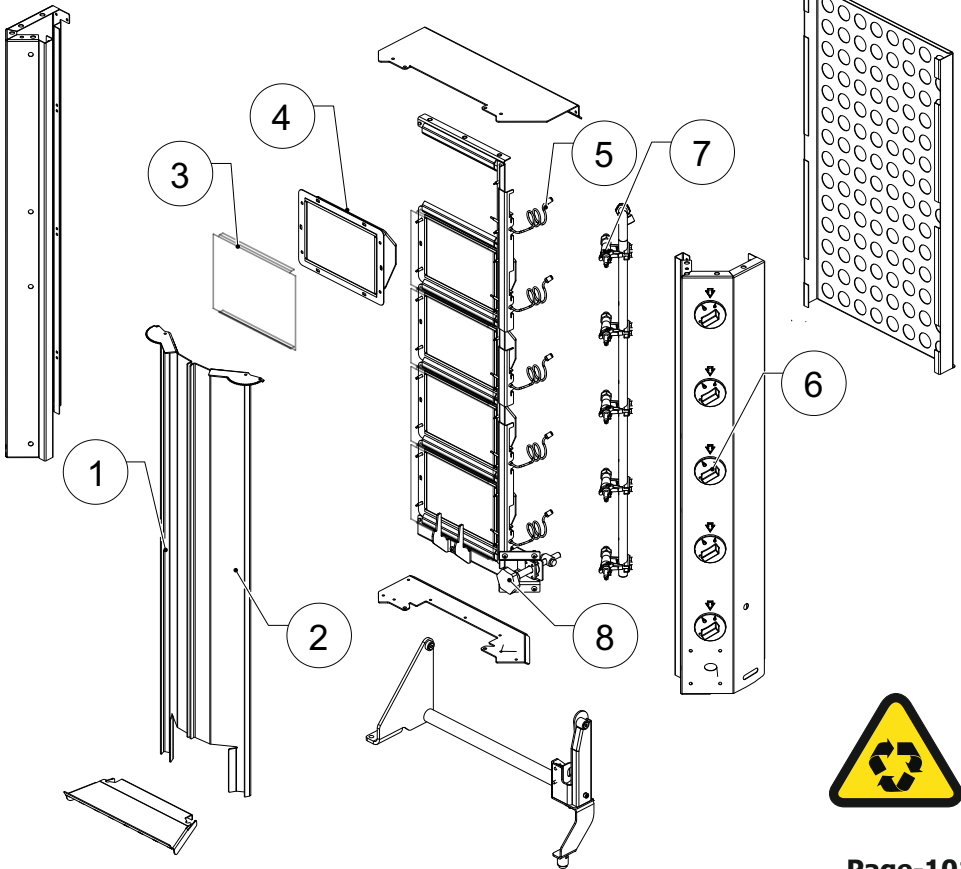
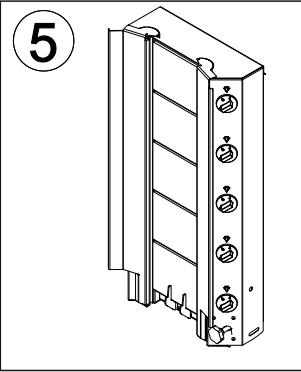

11. EXPLODED ASSEMBLY AND PARTS LIST
11.32 M014767 - DRAT4E - Electric Cooker - 1

M014767-1

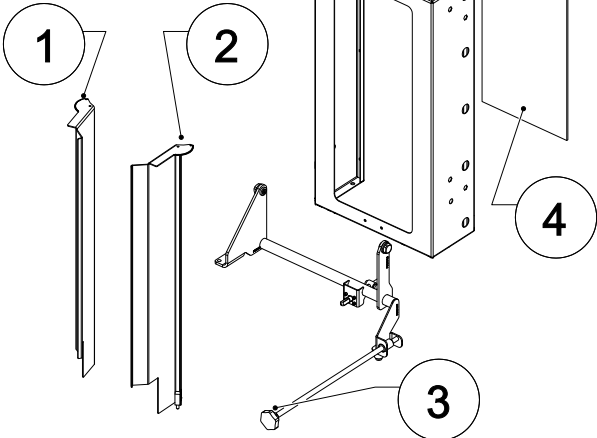
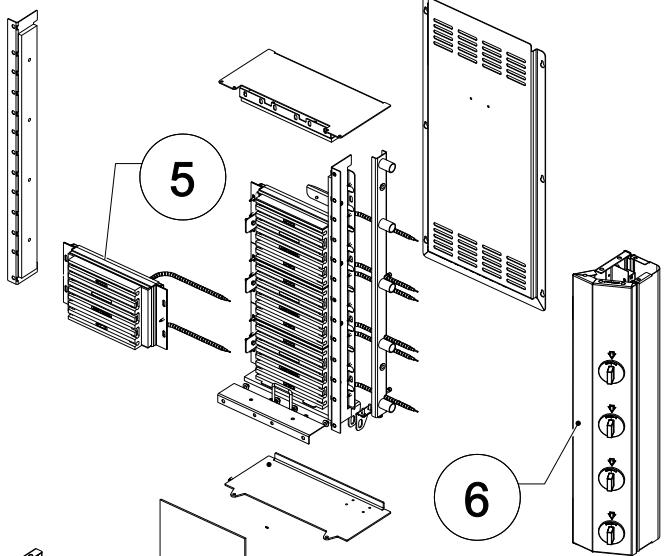
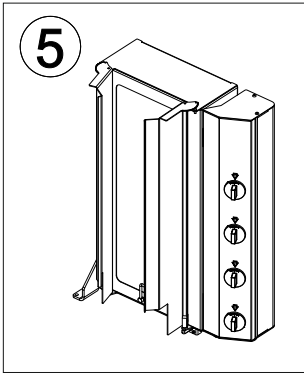

S.N	P-M Code
1	P037971
2	P038084
3	P024005
4	P037979
5	M013432
6	M014770



Warning!!!
The power supply line of your Doner Robot necessarily grounding in accordance with standards must be used with electrical installations!



11. EXPLODED ASSEMBLY AND PARTS LIST
11.33 M014767 - DRAT4E - Electric Cooker - 2

M014767-2

M014770

S.N	P-M Code
7	P007514
8	P006575
9	P006659
10	P006666
11	P006667
12	P027803
13	P003027

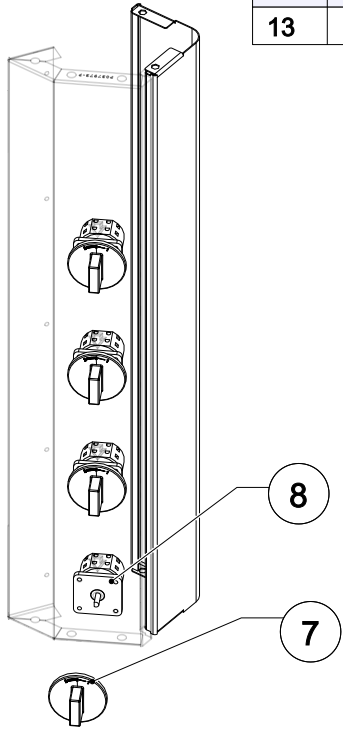
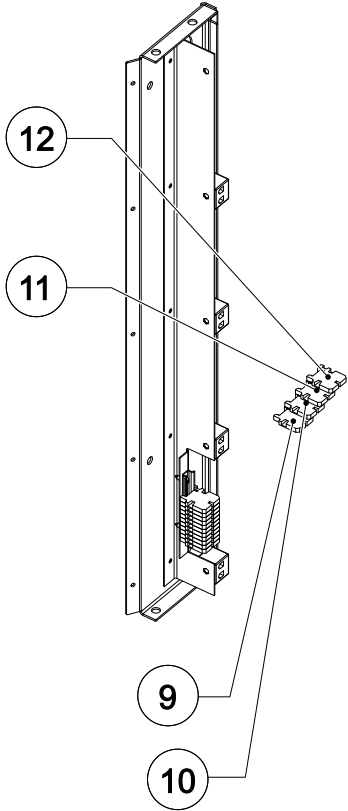
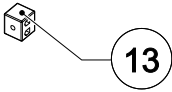
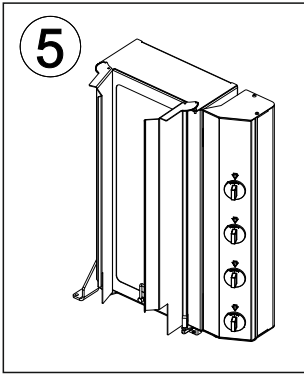

Warning!!!
The power supply line of your Doner Robot necessarily grounding in accordance with standards must be used with electrical installations!



11. EXPLODED ASSEMBLY AND PARTS LIST
11.34 M014045 - DRAT5E - Electric Cooker - 1

M014045-1

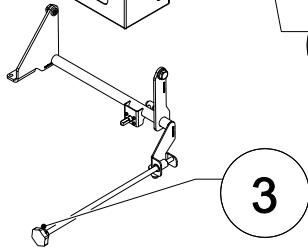
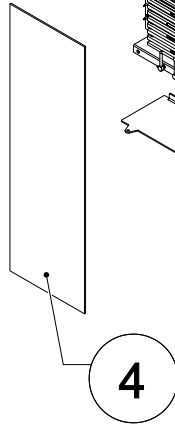
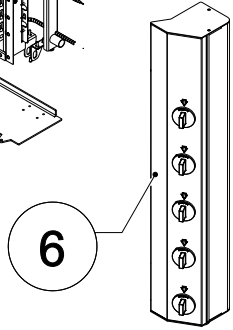
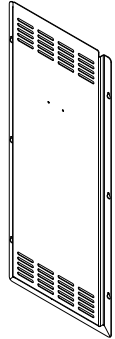
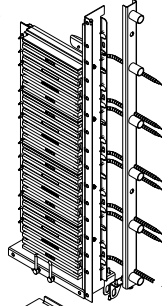
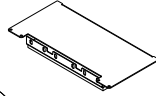
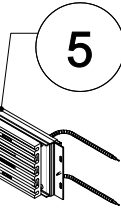
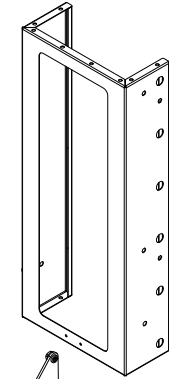
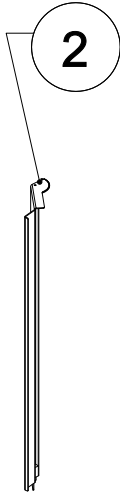
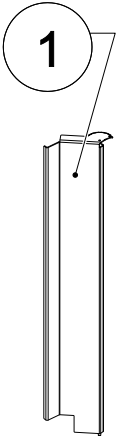
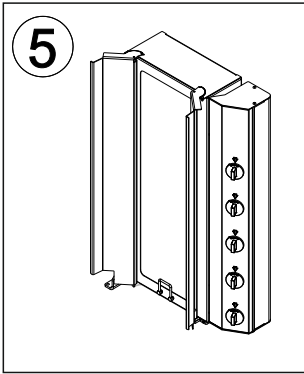

S.N	P-M Code
1	P033722
2	P033723
3	P024005
4	P002691
5	M013432
6	M013774



Warning!!!
The power supply line of your Doner Robot necessarily grounding in accordance with standards must be used with electrical installations!



11. EXPLODED ASSEMBLY AND PARTS LIST
11.35 M014045 - DRAT5E - Electric Cooker - 2

5

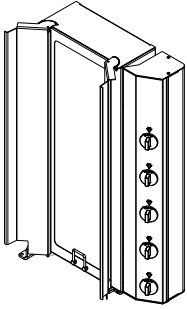

M014045-2

M013774



S.N	P-M Code
7	P007514
8	P006575
9	P006659
10	P006666
11	P006667
12	P027803
13	P003027

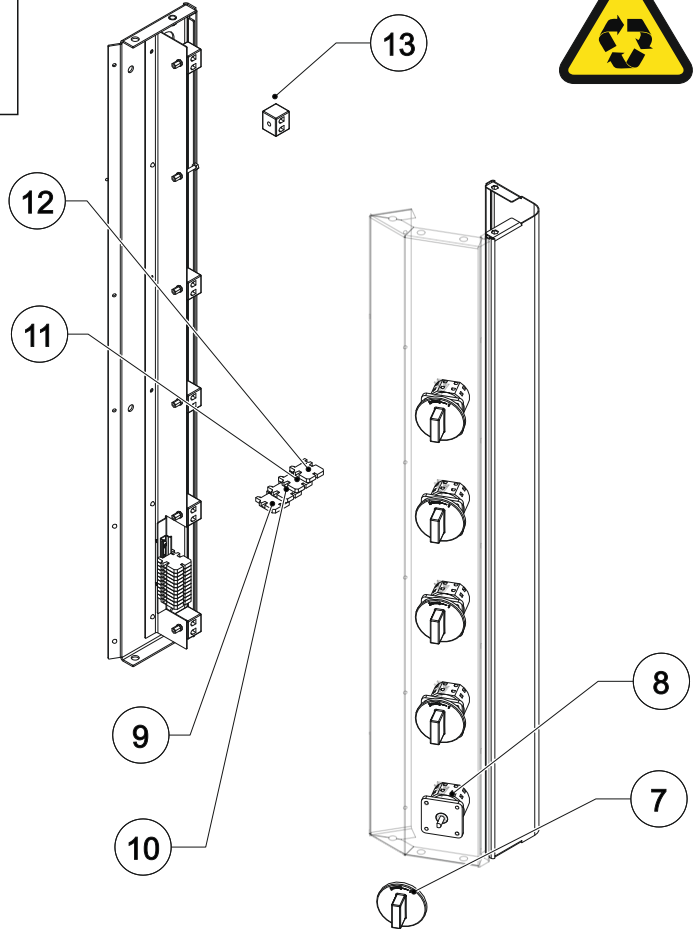

Warning!!!
The power supply line of your Doner Robot necessarily grounding in accordance with standards must be used with electrical installations!



11. EXPLODED ASSEMBLY AND PARTS LIST

11.36 M012175 ADR-C1-4G/4E - Standard 12 x 12 Square Type Skewers

6

M012175

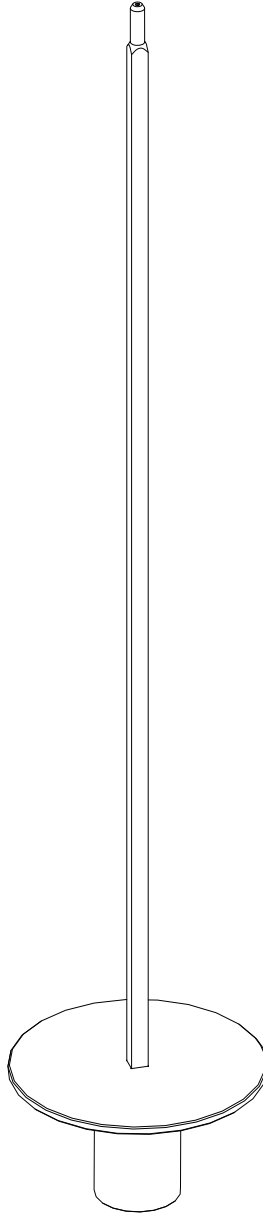

S.N	P-M Code
1	M012175

11. EXPLODED ASSEMBLY AND PARTS LIST
11.37 M013074 ADR-C1-4G/4E - Optional 30 x 10 Flat Shank

M013074

6

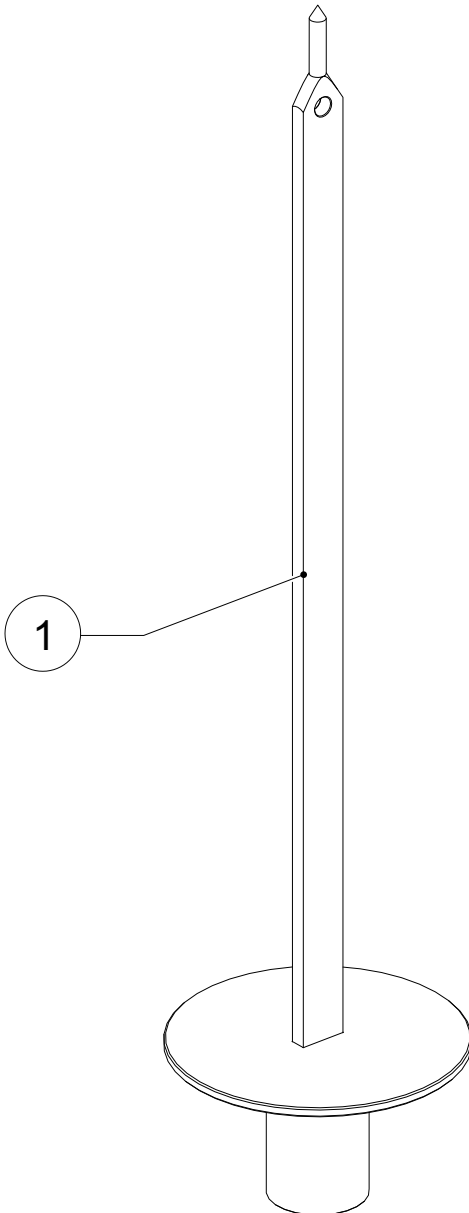

S.N	P-M Code
1	M013074

11. EXPLODED ASSEMBLY AND PARTS LIST
11.38 M000821 DRAT5E - Standard 12 x 12 Square Type Skewers

6

M000821

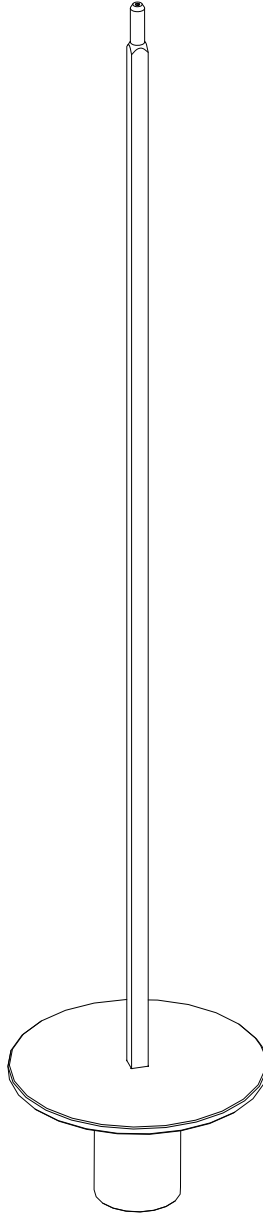

S.N	P-M Code
1	M000821

11. EXPLODED ASSEMBLY AND PARTS LIST
11.39 M012176 DRAT5E - Optional 30 x 10 Flat Shank

M012176

6

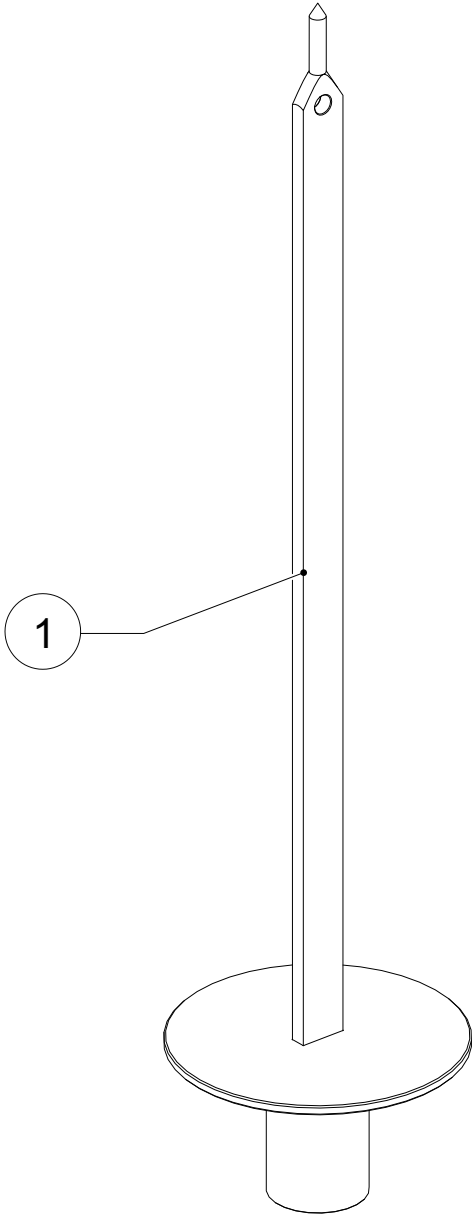

S.N	P-M Code
1	M012176

11. EXPLODED ASSEMBLY AND PARTS LIST
11.40 M014465 DRAT5E - Robot Table

7

M014465

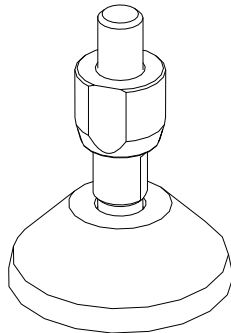
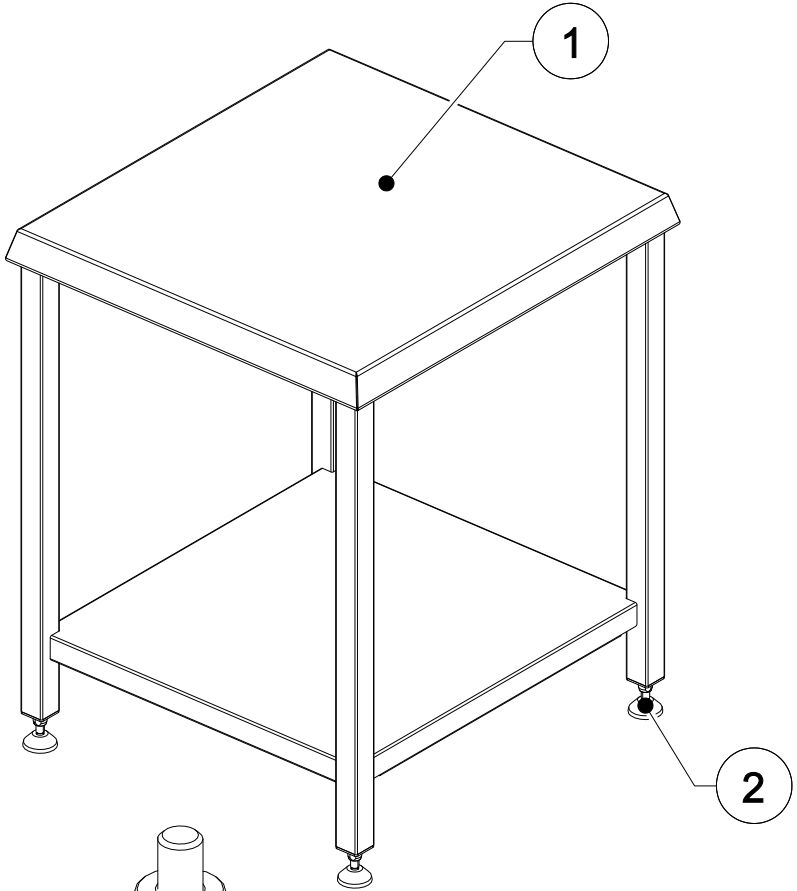

M013393

S.N	P-M Code
1	M014466
2	M013393



11. EXPLODED ASSEMBLY AND PARTS LIST

11.41 P023612-Ø320 mm Mirror (Standard)-P023613-Ø440 mm Mirror (Optional)

8

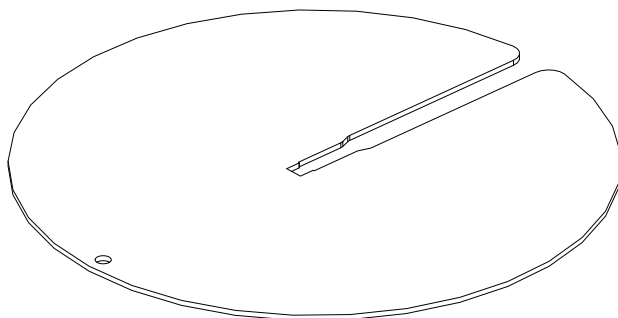

P023612

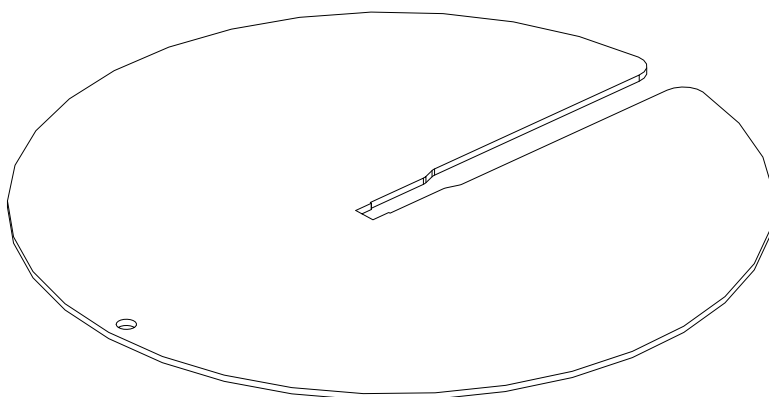

P023613





GGM Gastro International GmbH
Weinerpark 16
D-48607 Ochtrup

www.ggmgastro.com

info@ggmgastro.com

+49 2553 7220 0