

TPOGL3

Gas pizza oven

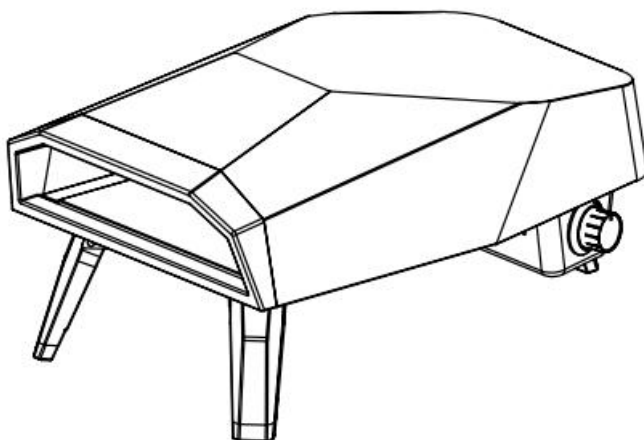

WARNING

Spiders and insects can nest inside the burner of the appliance and disrupt gas flow. Inspect the burner at least once a year.

WARNING

Do not store his appliance indoors unless the gas cylinder is disconnected.

WARNING

Do not store gas cylinder in a building, garage or any other enclosed area and keep out of reach of children at all times.

WARNING

This appliance is not intended to be installed in or on recreational vehicles and/or boats.

WARNING

Check all gas supply fittings for leaks before each use. Do not use the appliance until all connections have been checked and do not leak.

WARNING

Do not smoke while leak testing. Never leak test with an open flame.

WARNING

When lighting, keep your face and hands as far away from the appliance as possible.

WARNING

Minimum clearance from sides of unit to combustible construction is 500mm.

Minimum clearance from back of unit to combustible construction is 500mm.

WARNING

Do not modify the appliance.

WARNING

To reduce the risk of fire, burn hazard or other injury, read this safety manual carefully and completely before using this appliance.

WARNING

Before cleaning, make sure the gas supply and control knob is in the OFF position and that the burner and oven has cooled.

Failure to follow these instructions could result in fire, explosion or burn hazard which could cause property damage, personal injury or death.

WARNING

FOR OUTDOOR USE ONLY.

DANGER

If you smell gas:

- Shut off gas to the appliance
- Extinguish any open flame
- If the smell persists, keep away from the appliance and immediately call your gas supplier or your fire department.

WARNING

a.Keep the fuel supply hose away from any heated surface(s).

b.The use of alcohol, prescription or non-prescription drugs may impair the consumer's ability to properly assemble or safely operate the appliance.

c.Keep children and pets away from the appliance at all times.

d. Do not move the appliance when in use.

e. This appliance is not intended for and should never be used as a heater.

- The parts which have been sealed by the manufacturer should not be adjusted by the user
- When the appliance is using LPG & LPG cylinder should be used
- The LPG cylinder size: max diameter-390mm, max height-455mm.
- The minimum distances between the appliance and adjacent walls is 0.5m
- The hose for the appliance should not exceed 1.5m
- The gas supply tubing or hose shall comply with the national requirements in
- Force and shall be periodically examined and replaced as necessary.
- The hose should comply with the standard EN16436. The regulator should comply with the standard EN16129.
- The necessity of changing the flexible tube when the national conditions require it, and depending on its validity.
- Check and suitably clean the inside of the oven before it is lit in order to avoid the emission of fire from the oils that have accumulated during previous cooking.
- The burner outlets should be checked for obstruction during previous cooking.
- The burner outlets should be checked for obstruction and cleaned regularly with a soft wire brush.
- It is necessary to avoid obstruction and to allow for a good combustion.
- The position of the connection flexible tube so as to ensure that it is not subjected to twisting.



SAFETY PRACTICES TO AVOID INJURY

When properly cared for, your oven will provide safe, reliable service for many years. However, extreme care must be used as the oven produces intense heat that can increase the risk of accidents.

When using this oven basic practices must be followed, including but not limited to following:

- Do not repair or replace any part of the oven unless specifically recommended in this manual. All other service should be referred to a qualified technician.
- Children should not be left alone or unattended in an area where the oven is being used. Do not allow children to sit, stand or play around the oven at any time.
- Never let clothing or other flammables come in contact with or too close to any burner or hot surface until it has cooled. The fabric could ignite, causing serious personal injury.
- For personal safety, wear proper apparel. Loose fittings garments or sleeves should never be worn while using the oven. Some synthetic fabrics are highly flammable and should not be worn while cooking.
- Do not heat unopened food containers as a buildup of pressure may cause the containers to burst. When lighting the burner, always pay close attention to what you are doing.
- When using the oven, do not touch the outer shell, stone baking board or immediate surroundings as these

areas become extremely hot and could cause burns.

- Do not use the oven to cook extremely fatty meats or other products which increase flare-up.
- Keep the area around the oven free of combustibles, including liquids, garbage, and steam, such as gasoline or charcoal lighter fluid. Do not obstruct the flow of combustion and ventilation air.
- Never use the oven in extremely windy conditions.
- The temperature under the oven is high. Do not place the oven on a table with flammable table cloths, plastic or any other inflammable materials.
- The recommendation of the use of protective gloves when handling particularly hot components.

Appliance Name	Outdoor Gas Grill				 PIN: 51DN5100 XXXX YY
Model No.	P200				
Appliance Category	I3+(28-30/37) <input type="checkbox"/>		I3B/P(30) <input type="checkbox"/>	I3B/P(37) <input type="checkbox"/>	I3B/P(50) <input type="checkbox"/>
Type of gas	Butane	Propane	Butane,Propane or their mixture	Butane,Propane or their mixture	Butane,Propane or their mixture
Gas Pressure	28-30mbar	37mbar	30mbar	37mbar	50mbar
Country of Destination	BE, CY, CZ, ES, FR, GB, GR, IE, IT, LT, LU, PT, SI		BG, CY, DK, EE, FI, HR, HU, IT, IS,LT, LU, MT, NL, NO, RO, SE, SI, TR	PL	AT, DE, CH
Total Heat Input (kW)	4.65				
Gas consumption(g/h)	G30 : 338 ; G31 : 332				
Injector	Main grill	1.08 mm	1.08 mm	1.01 mm	0.94 mm
⚠ WARNING					
<p>*Use outdoors only</p> <p>*Read the instructions before using the appliance</p> <p>*Warning: Accessible parts may be very hot. Keep away from young children.</p> <p>*This appliance must be kept away from flammable materials during use</p> <p>*Do not move the appliance during use</p>					
<p>Manufactory: Foshan Hanshi Heat Energy Science & Technology Co., Ltd.</p> <p>Address: Floor 5 and 6, 17th Building, Zhifu Industrial Area, 2nd Ring Road, Gaozan Village, Xingtang Town, Shunde District, Foshan City, Guangdong Province, CHINA</p>					

DEVICE OVERVIEW AND INDIVIDUAL PARTS

1. Pizza Stone

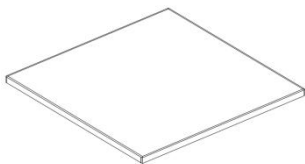

2. Pizza Oven Body

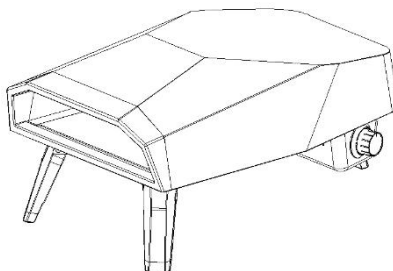

ASSEMBLY

Before assembly, make sure all parts are present. If any part is missing or damaged, do not attempt to assemble the appliance.

Contact customer service for replacement parts.

1. Unfold legs

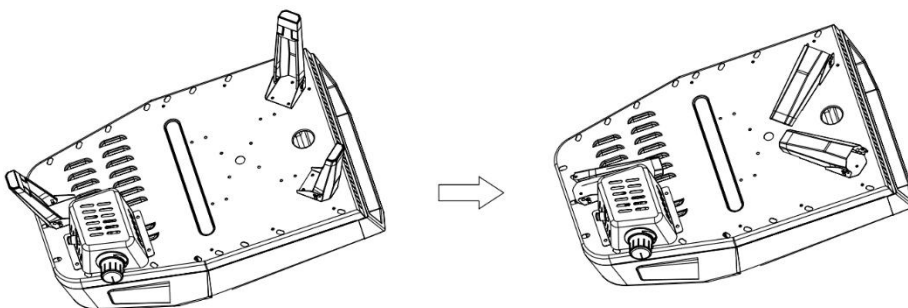

2. Insert the baking board in the oven.

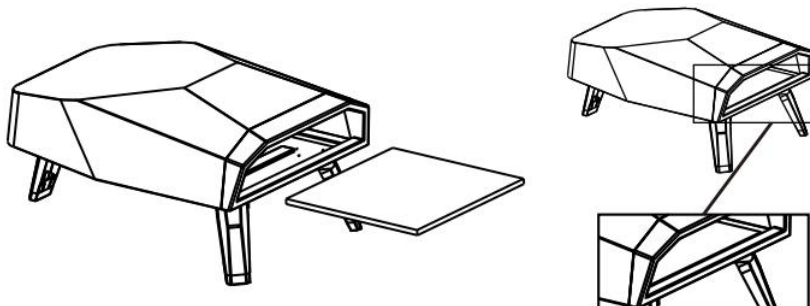

3. Connect the gas hose to the pizza oven.

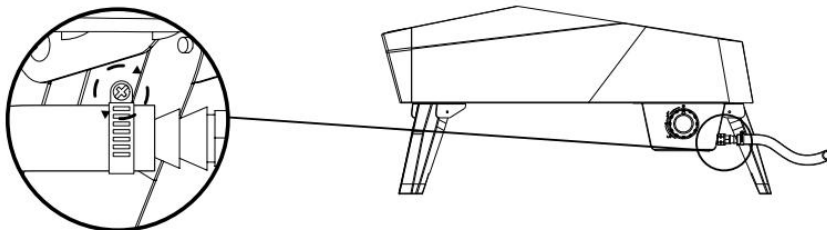

4. The minimum distance between the equipment and the cylinder is 0.6 m

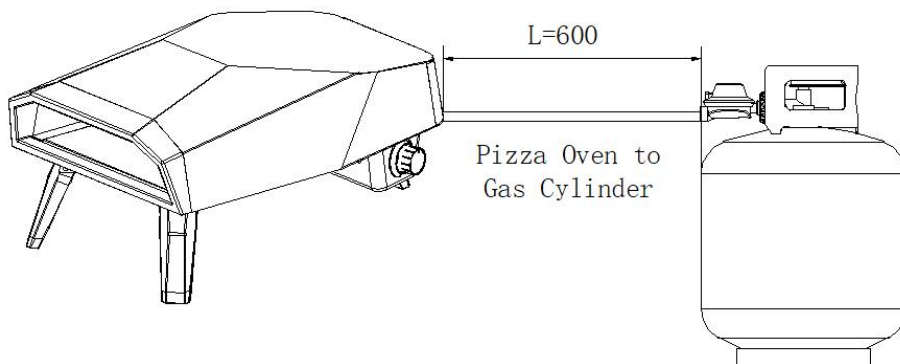

WARNING

- Please always keep the gas bottle in upright position.
- The size for 20 lbs LP gas cylinder is 390mm in diameter and 455mm tall
- If the appliance is not in use, the gas must be turned off at the supply cylinder.
- The cylinder used must include a collar to protect the cylinder valve.
- The minimum distance for the appliance and the 20lb gas tank is 600mm apart.
- when changing the gas cylinder which shall be carried out away from any source of ignition
- The absolute necessity of not obstructing the ventilation openings of the cylinder compartment

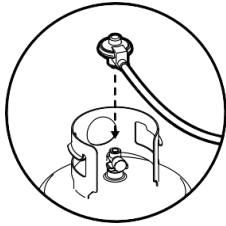

PATIO GAS REGULATOR

This is a push-on gas fitting. Ensure that the black switch is in the horizontal position. Depress the button located below the black switch and press the regulator on to the tank valve until it locks into place.

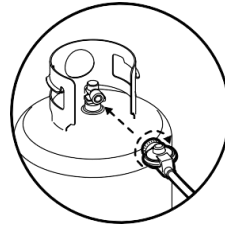

GAS REGULATOR

This gas fitting is counterclockwise. Make sure that the tank is completely switched off and screw the regulator as far as possible into the gas tank valve.

CONNECTING THE LIQUID PROPANE GAS CYLINDER

- 1.To connect the liquid propane gas cylinder:
- 2.The cylinder valve should be in OFF position.
- 3.Make sure the burner valve is in OFF position.
- 4.Inspect the valve connections, port and regulator assembly. Remove debris and inspect the hose for damage.
- 5.When connecting the regulator assembly to the valve, use your hand to tighten the nut clockwise until it stops. Use of a wrench could damage the quick coupling nut and result in a hazardous situation.
- 6.Open the cylinder valve fully by turning the valve counterclockwise.
- 7.Before lighting the oven, use a soap and water solution to check all connections for leaks.
- 8.If a leak is found, turn the cylinder valve OF, and do not use the oven until local liquid propane dealer can make repairs.

DISCONNECTING THE LIQUID PROPANE GAS CYLINDER

1. Turn the oven burner valve **OFF** and make sure the oven is cool.
2. Turn the liquid propane cylinder valve **OFF** by turning clockwise until it stops.
3. Detach the regulator assembly from the cylinder valve by turning the quick coupling nut counterclockwise.
4. Place dust cap for cylinder valve outlet whenever the cylinder is not in use.

LEAK TESTING

GENERAL

Although the gas connections of the appliance are leak tested prior packing and shipment, a complete test must be performed at the installation site.

Before each use, check all the gas connections for leak testing using the procedure listed below. If the smell of gas is detected at any time, you should immediately stop using and check the entire system for leaks.

BEFORE TESTING

Make sure all packing material has been removed from the appliance.

Make a solution of one part liquid detergent and one part water. You will need a spray bottle, brush or rag to apply the solution to the fittings.

TO TEST

1. Turn the burner valve **OFF**
2. Turn the liquid propane cylinder valve on counterclockwise to open the valve.
3. Apply the soap solution to all gas fittings. Soap bubbles would appear where a leak is present.
4. If a leak is present, immediately turn the gas supply **OFF** and tighten leaky fittings.
5. Turn the gas back **ON** and recheck.
6. Should the gas continue to leak from any of the fittings, turn the gas supply **OFF** and contact customer service.

OPERATING INSTRUCTIONS

USING THE OVEN

Each burner is rated at **4.65KW**. To begin:

1. Make sure the oven has been leak tested and properly placed.
2. Remove any remaining packing material.
3. Light the burner using the LIGHTING INSTRUCTIONS below

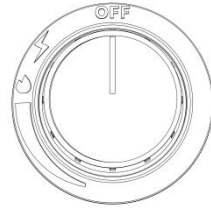

LIGHTING INSTRUCTION TO LIGHT THE BURNER

1. Make sure the control knob is in OFF position, and then turn the liquid propane cylinder valve ON by slowly turning counterclockwise.
2. Push in and slowly turn the control knob anticlockwise until you hear a click and the burner ignites.
3. If burner doesn't light, turn the knob OFF, wait 5 minutes and repeat the lighting.

TO LIGHT WITH A MATCH

1. If burner will not light after several attempts using the control knob, the burner may be lit with a match.
2. If you have already attempted to light the burner using the control knob, wait 5 minutes for any gas to dissipate.
3. Insert a match into the matchstick holder, ignite the match and insert through the oven opening to the burner.
4. Push and turn the control knob to HI slowly, the burner should ignite immediately.
5. If the burner does not light within seconds, turn the control knob OFF and wait 5 minutes and try again.

CARE AND MAINTENANCE

Store P200F out of direct sunlight and indoors where possible and when storing for extended periods of time. P200F should not be exposed to harsh weather conditions such as snow, heavy rain and strong winds.

Wait for P200F to cool completely before moving

The outer shell of P200F may fade over time and through use. This will not affect performance.

STONE BAKING BOARD

1. DO NOT use the stone over an open flame
2. Avoid extreme temperature change to the stone. DO NOT place frozen foods on a hot stone

3. The stone is fragile and can break if bumped or dropped
4. The stone is very hot during use and stays hot for a long time after use.
5. DO NOT cool the stone with water when the stone is hot
6. After cleaning the stone with water, please dry the stone before use. This can be done in a conventional oven at 60°C (140°F) for 2 hours.

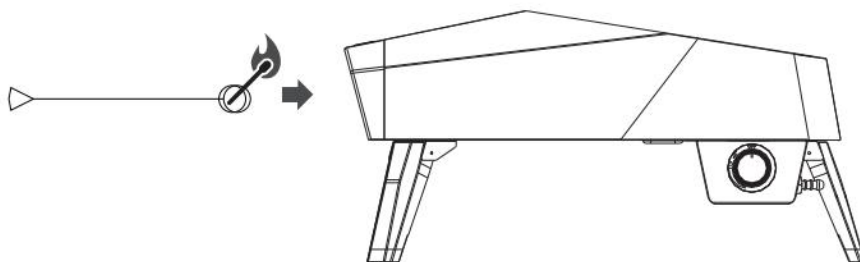

TROUBLESHOOTING

Problem	Possible Cause	Prevention/Solution
Burner will not light	<ol style="list-style-type: none"> 1. No gas flow 2. Coupling nut and regulator not fully connected 3. Obstruction of gas flow 4. Disengagement of burner to valve 5. Incorrect assembly 	<ol style="list-style-type: none"> 1. Check to see if propane tank is empty 2. Turn the coupling nut about one-half to three quarters additional turn until solid stop. Tighten by hand only – do not use tools 3. Clear burner tube 4. Reengage burner and valve 5. Check steps in assembly instructions
Sudden drop in gas flow or low flame	<ol style="list-style-type: none"> 1. Out of gas 	<ol style="list-style-type: none"> 1. Check for gas in propane tank 2. Turn off gas control knob, wait 30 seconds and light oven. If flames are still low, turn off gas control knob and propane tank valve. Disconnect regulator. Reconnect regulator and leak test. Turn on propane tank valve, wait 30 seconds and then light oven.
Flames blow out	<ol style="list-style-type: none"> 1. High or gusting winds 2. Low on propane gas 	<ol style="list-style-type: none"> 1. Turn front of oven away from wind 2. Refill propane tank 3. Refer to Sudden drop in gas flow

		above
Flare-up	<ol style="list-style-type: none"> 1. Grease buildup 2. Excessive fat in meat 3. Excessive cooking temperature 4. Excess flour on the cooking surface 	<ol style="list-style-type: none"> 1. Clean oven 2. Trim fats from meat before cooking 3. Adjust (lower) temperature accordingly 4. Brush remnant flour from cooking surface 5. Flip stone
Flashback (fire in burner tube, roaring sound from burner)	<ol style="list-style-type: none"> 1. Burner and/or burner tubes are blocked 2. Pressure drops during ignition 	<ol style="list-style-type: none"> 1. Turn gas control knob off. Clean burner and/or burner tubes. 2. Turn off oven, ensure the tank valve is fully open (if applicable) and relight.

Cleaning and Maintenance of the Gas Pizza Oven

General Safety Instructions

- **Ensure the gas supply is turned off, and the oven has completely cooled before starting the cleaning process.**
 - **Avoid using harsh chemicals or abrasive materials to prevent damage to the surfaces.**
 - **Wear heat-resistant gloves when cleaning if the oven is not fully cooled.**
-

Cleaning the Outer Surfaces

1. **Cool Down:** Wait until the oven is completely cool.
 2. **Clean:** Wipe the outer surfaces with a soft, damp cloth and mild dish soap.
 3. **Dry:** Thoroughly dry all surfaces to prevent rust.
-

Cleaning the Baking Stone

1. **Remove Residues:** Gently scrape off food residues with a soft brush or scraper.
2. **Avoid Chemicals:** Only use water to clean the stone; chemicals may affect its baking performance.
3. **Dry:** After cleaning, dry the stone in a conventional oven at 60°C (140°F) for about two hours.

Caution: The baking stone is fragile and can break with sudden temperature changes or impacts. Do not place frozen food on a hot stone.

Cleaning the Burners

1. **Inspect:** Regularly check the burners for blockages.
 2. **Clean:** Use a soft wire brush to remove any debris from the burner outlets.
 3. **Keep Clear:** Ensure all burner openings are clear for optimal combustion.
-

Routine Maintenance

- **Regularly inspect all gas connections and perform leak tests.**

- **Store the oven in a dry location, away from harsh weather conditions like snow or heavy rain.**
 - **Replace damaged or worn hoses and regulators as specified by the manufacturer.**
-

Storage

- **Store the oven indoors when possible, but only if the gas cylinder has been detached.**
 - **Protect the oven from direct sunlight to avoid discoloration or deformation of the outer shell.**
-

Additional Notes

- **Do not use water jets or high-pressure cleaners for cleaning.**
- **Keep the area around the oven free of combustible materials, even during cleaning.**

By properly cleaning and maintaining your gas pizza oven, you ensure its optimal performance and longevity.



GGM Gastro International GmbH
Weinerpark 16
D-48607 Ochtrup

www.ggmgaastro.com info@ggmgaastro.com
+49 2553 7220 0