

# ggmgastro

## 30 KG.POTATO PEELER ( ELECTRICAL – INDUSTRIAL TYPE )



### USER'S MANUAL

MODEL: KSEOZ

AUTHORIZED DEALER  
SERVICE STICKER WILL  
BE ATTACHED HERE.

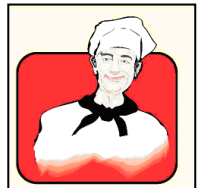

**PRODUCTION YEAR:**

**SERIAL NO :**

CE

MANUFACTURER : GGM Gastro International GmbH .

•**PRODUCTION SITE** : GGM Gastro International GmbH Weinerpark 16 48607 Ochtrup

Tel: +49 (0) 2553 / 7220 0 Fax: +49 (0) 2553 / 7220 200

Our website: [www.ggmgastro.com](http://www.ggmgastro.com)

e-mail: [technik@ggmgastro.com](mailto:technik@ggmgastro.com)

**Published on : 05.05.2023**

# TABLE OF CONTENTS

---

PAGE NR.	TOPICS
1	COVER PAGE
2	TABLE OF CONTENTS
3	INTRODUCTION
4	TECHNICAL DATA
5	ELECTRICAL CIRCUIT DIAGRAM,CONTROL BOARDS
6 - 7	MAIN DIMENSIONS AND WARNING SIGNS
8	SAFETY DETAILS
9	TRANSPORTING AND MOVING
10	INSTALLATION OF THE APPLIANCE
11-12	OPERATION OF THE APPLIANCE
13	CLEAN-UP AND MAINTENANCE
14-16	TROUBLE SHOOTING
17	TERMS OF WARRANTY



## **CAUTION**

The power network of the building, facility or any similar site, where this device will be connected to power supply, should comply with "INDOOR ELECTRICAL INSTALLATION" regulation all necessary action should be taken in order to maintain personal and material safety when connecting this device to power supply. OTHERWISE OUR COMPANY WILL NOT BE RESPONSIBLE FOR THE CONSEQUENCES.

# INTRODUCTION

---

Dear User,

Thank you for purchasing our appliance and for your reliance upon our company. Our appliances are used in professional kitchens in 100 countries. Our appliances are produced in compliance with international standards. Important notice: Please read and ensure that the users read this user's manual in order to achieve the desired performance in line with your expectations and to use your appliance for long years. Please take the warnings mentioned above into consideration before calling for service...

 Please read and ensure that your operation personnel also reads this user's manual carefully before installing and using the appliance. If the appliance is operated without reading the user's manual, the appliance will not be covered by the warranty.

 The manual containing information about installation, usage and maintenance of our product you purchased should be read carefully. Please ensure that power supply connections to the appliance are already installed by qualified personnel according to local legislation, before our authorized service personnel arrives for the installation of the appliance.

 If you are confused or you don't have enough information please get in touch with authorized service by phone.

 Please keep in mind that, if the service personnel is delayed at your site, related expenses and delay costs will be charged to you on hourly basis.



 We hope that you will get the best performance from our product...

# TECHNICAL DATA

 YOUR PRODUCT'S TYPE	KSEOZ (WITH SIDE DRAWER)
PRODUCT CODE	THREE-PHASE
MAIN DIMENSIONS (mm)	0840.00030.31
TOTAL ELECTRICAL INPUT (kW)	620X980X1430
POWER SUPPLY VOLTAGE	1,5
WORKING FREQUENCY (Hz)	380 - 400
NOMINAL CURRENT (A)	50-60
SUPPLY CABLE	3,9
OPERATIONAL CAPACITY (KG/BATCH)	5X2,5
NET WEIGHT (Kg)	30
MAXIMUM NOISE (dBA)	101
MAXIMUM SLOPE	73
PROTECTION CLASS	5°
CLASS	1
WATER INLET (inch)	IPX4
WATER OUTLET (inch)	3/4 "
WATER OUTLET (inch)	1 1/2"

# ELECTRICAL CIRCUIT DIAGRAM

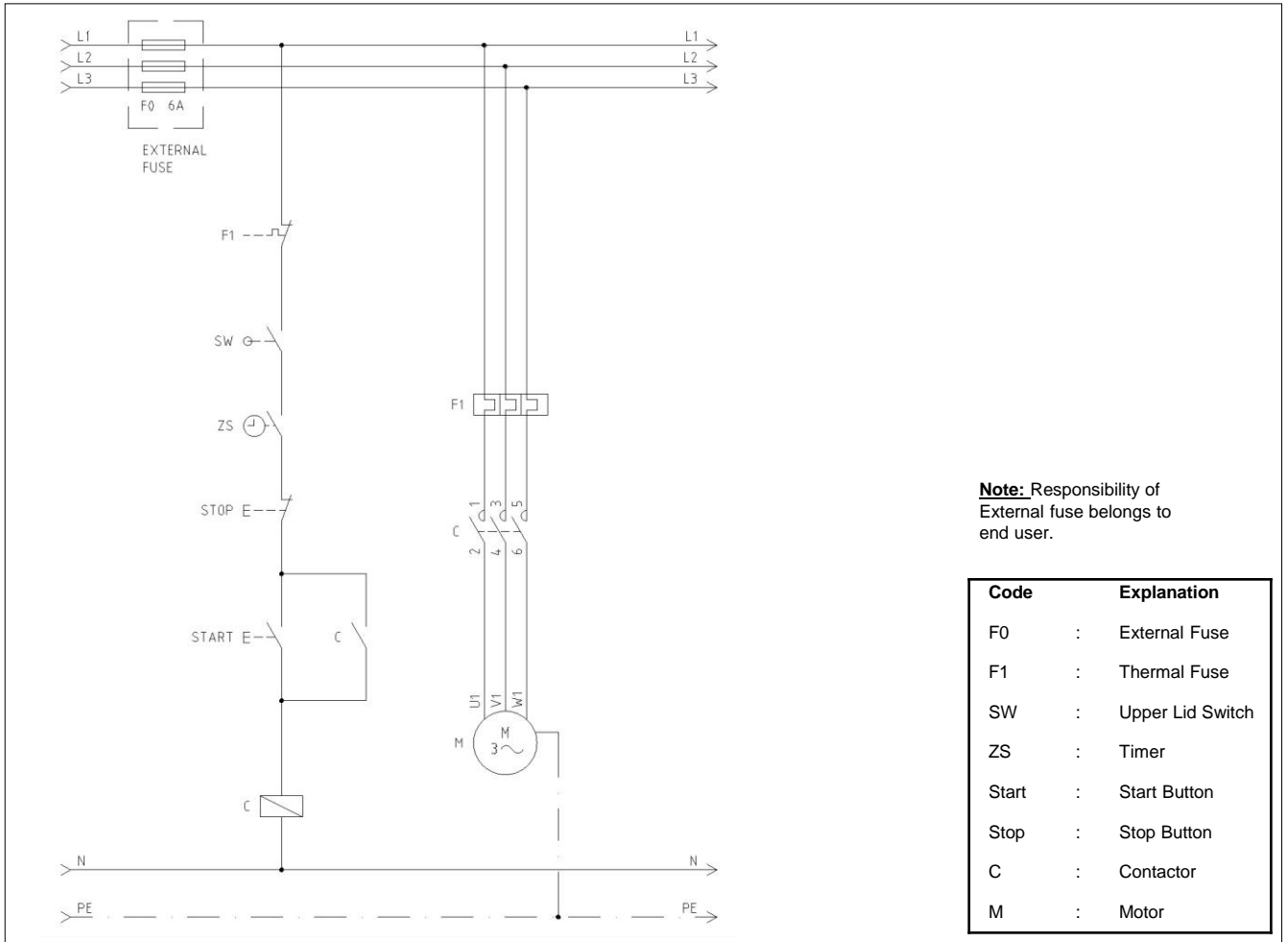

# CONTROL BOARDS

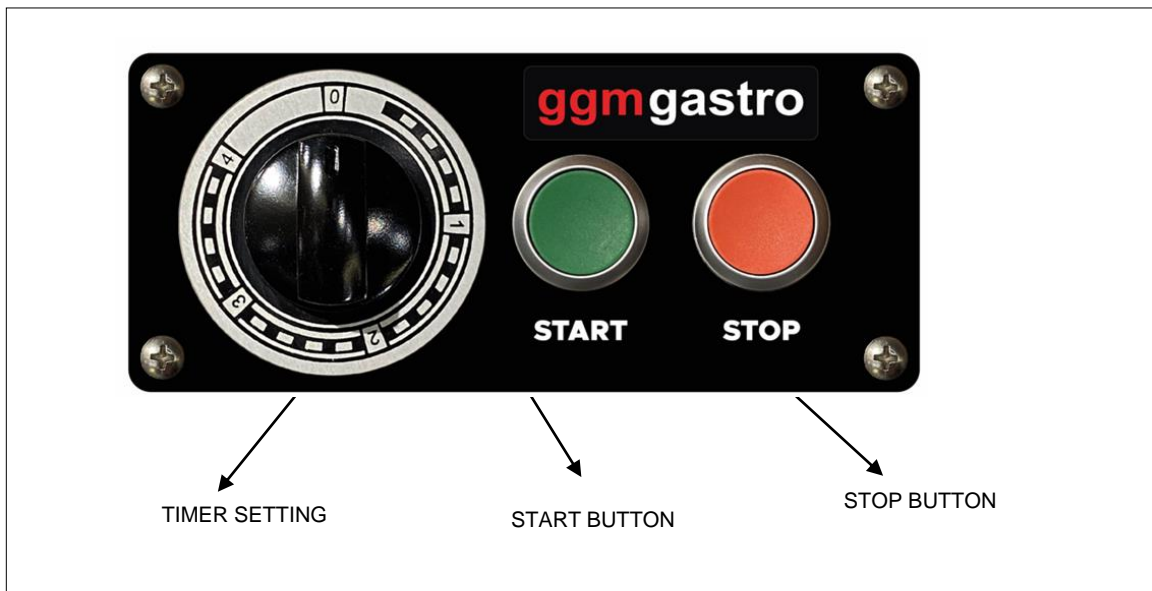

# MAIN DIMENSIONS

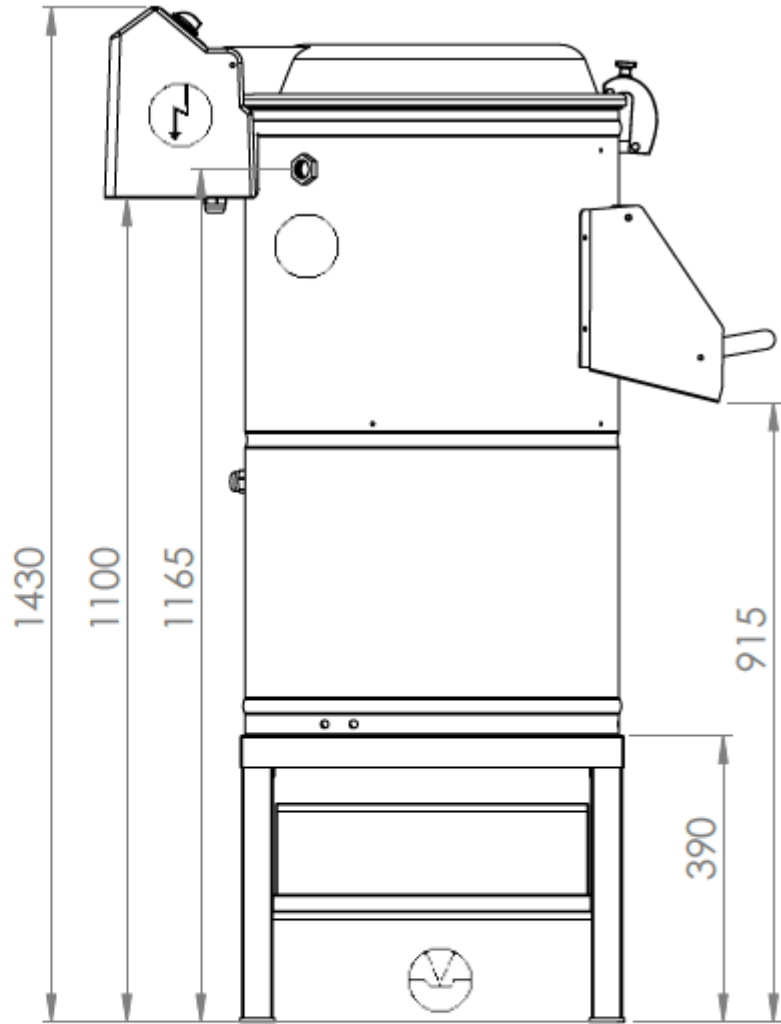
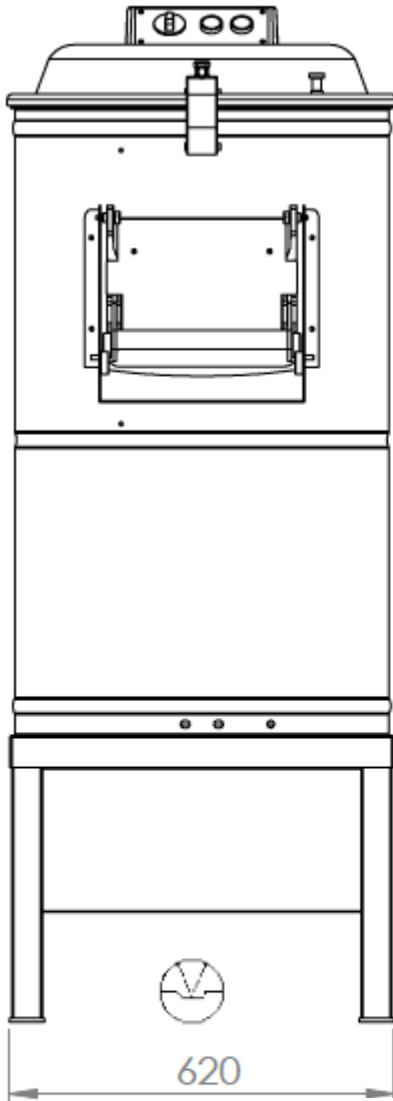

With Side  
Drawer Models



MODEL: KSEOZ  
CODE:0840.00030.31

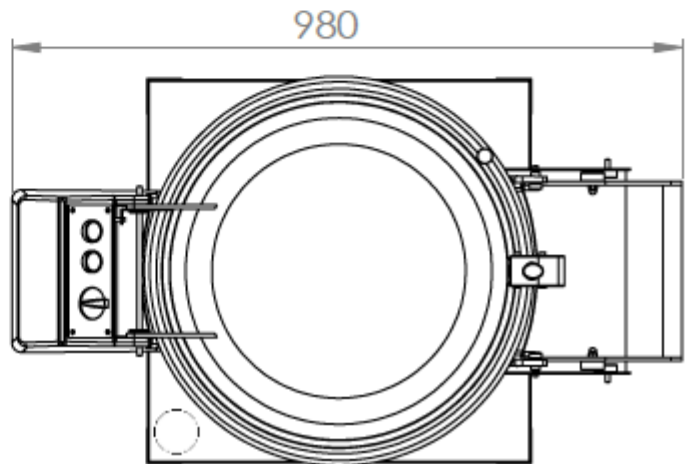

# WARNING SIGNS



**POWER NETWORK GROUNDING**



**PE**

**GROUNDING**



**POWER**

400 V 3 NPE / 50-60 Hz  
VOLTAGE : 400 V  
SUPPLY CONNECTION: 3 PHASE  
GROUNDED  
FREQUENCY : 50/60 Hz

# SAFETY DETAILS

---

☞ Do not clean up the device with pressure water

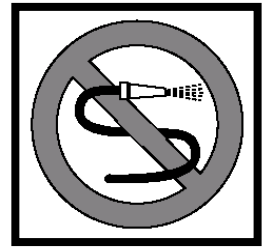

☞ This device should be installed in line with effective regulations and only be operated in well ventilated places. Please refer to the instructions before installing and operating the device.



☞ This device is designed for industrial use and should only be operated by personnel trained on the device.



☞ The device should not be handled by unauthorized persons except for the manufacturer or authorized service.



☞ In case of fire or flame in the area where the device is operated, act without panic, close gas valves (if any) , turn off the power switches and use a fire extinguisher. Never use water to extinguish the fire.



# TRANSPORTING AND MOVING

---

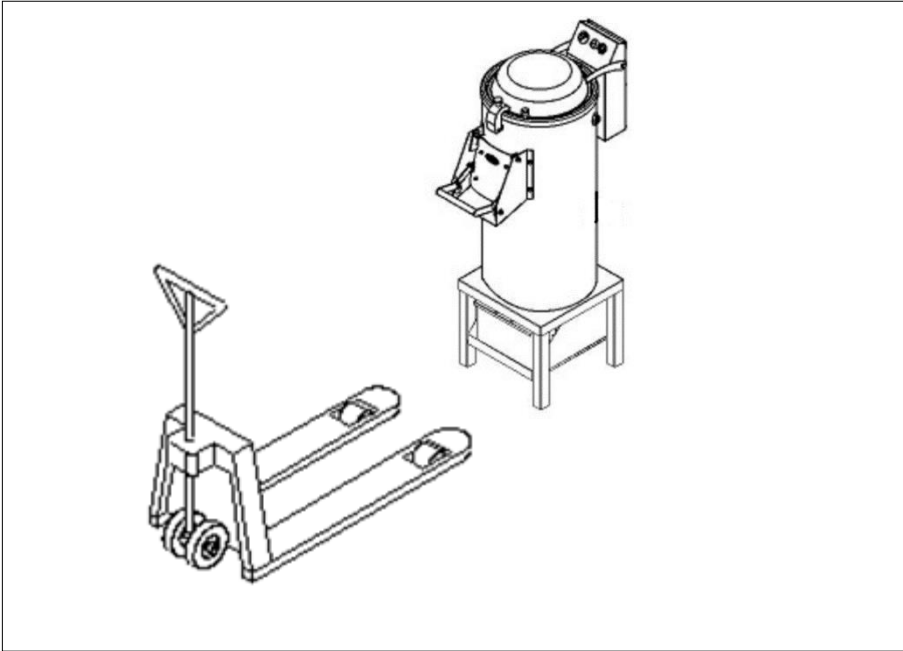

**CHANGING THE LOCATION;**  
Machines installed by an authorized service  
**CANNOT BE MOVED ELSEWHERE, ITS POWER SUPPLY  
CABLES CANNOT BE EXTENDED OR REPLACED** except  
by an authorized service.

- ☞ Disconnect from power supply before moving
- ☞ The vehicle can be moved with supplementary vehicles like fork lift.
- ☞ The device should be placed on a palette by manpower.
- ☞ If the transported distance is far, the machine should be moved slowly and the device should be fixed on palette or supported in order to prevent jolt.
- ☞ Do not hit or drop the device when moving.

# INSTALLATION OF THE APPLIANCE

---

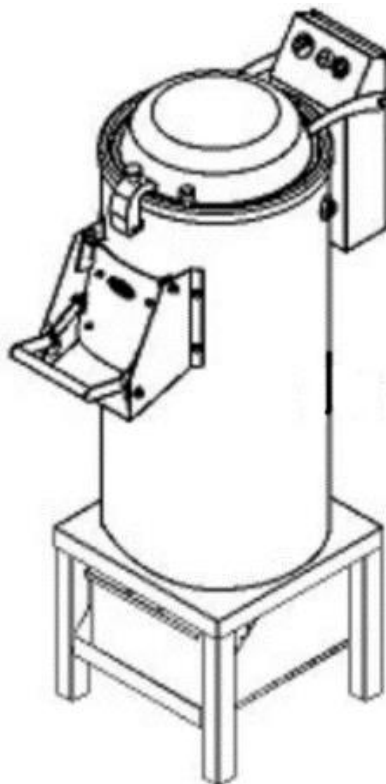

Installation of the device should be carried out by authorized service personnel.

- ☞ Power supply connection of the device should be checked by an eligible electrician, and it should be connected to a fuse at a maximum height of 170 cm.
- ☞ Power supply connection should be made using a 30 mA current leakage fuse as a protection against current leakage danger.
- ☞ Power installation to be used should be grounded by connecting it to a grounding bar at the nearest panel. Relevant fuse values to be used according to device power are given in Technical Data section (Page 4).

# OPERATION OF THE APPLIANCE

---

1. Potato peeler is used in tourist facilities, industrial kitchens, kitchens of catering enterprises, restaurants, fast food restaurants, kiosk-stands, canteens, patisseries, hotels etc. in order to peel potatoes.
2. After placing the device packed into the location where it will be operated, take the device carefully out of its package.
3. Before first use, entire outer surface and inside of the device must be cleaned up with liquid detergent and then rinsed with plenty of water.
4. Before filling the potatoes to be peeled into the device, debris, soil etc. within should be removed. Otherwise abrasive material on the peeler disc will be damaged. In such case the device will not be covered by the warranty anymore. With potatoes having flat surface, peeling quality will increase. Places on the potato surface with hollows cannot be peeled by the device, they should be peeled manually afterwards.
5. Potatoes got ready for peeling should be filled into the device and its water supply is turned on,
6. Peeling time is set through the timer on the control board. Set the switch on the control panel to "1" and push the start button. Peeling is started.
7. After the peeling is finished, the device automatically stops and the front hood is opened to discharge the potatoes inside and by pushing the start button is again, the potatoes are transferred into another container having appropriate volume.
8. After the discharging is over, stop button is pushed to stop the device.
9. After each batch of peeling the device is operated empty, in order to get rid of the residuals left in the kettle. If the kettle is not cleaned, residuals left inside may decrease peeling efficiency and cause infection within the kettle.
10. By intensive use, the device should be paused for a half hour, after 3 hours operation.



**CAUTION !**  
**NEVER OPERATE YOUR DEVICE  
WITHOUT GROUND CONNECTION.**

**NOTE: Do not use except purpose of use. The device should be operated by qualified personnel knowing safety terms and technical specifications and who has read the instruction manual.**



It is recommended to operate the device between temperatures of  $-5^{\circ}\text{C}$   $+40^{\circ}\text{C}$  and in ambient humidity of maximum 65%.

# OPERATION OF THE APPLIANCE

---



**CAUTION!** : The device should be installed and operated as described in this user's manual. If any failure is encountered please contact our nearest authorized service dealer.

WHEN THE DEVICE HAS A FAILURE ONLY AUTHORIZED  
..... SERVICE DEALERS ARE ALLOWED TO HANDLE  
THE DEVICE. IF ANY PERSON OTHER THAN ONLY  
AUTHORIZED SERVICE DEALERS HANDLE THE DEVICE,  
**IT WILL NOT BE COVERED BY THE WARRANTY.**

NEVER ALLOW PEOPLE WHO ARE NOT AUTHORIZED TO  
HANDLE THE DEVICE. OTHERWISE PRODUCER  
COMPANY WILL NOT BE RESPONSIBLE FOR THE  
CONSEQUENCES. DURING MAINTENANCE SERVICE OUR  
AUTHORIZED SERVICE DEALERS SHOULD NOT BE  
PROPOSED TO USE NON-ORIGINAL SPARE PARTS FOR  
WHATSOEVER. INSTALLING ANY NON-ORIGINAL SPARE  
PART TO THE DEVICE LEAVES THE DEVICE  
**OUT OF WARRANTY COVERAGE.**



# CLEAN-UP AND MAINTENANCE

---

## **1. CLEAN-UP:**

Turn the device off after daily use. Wipe the outer surface of the mixing apparatus and container with a sponge and liquid detergent. Top hood may be opened, to remove the peeler disc and to discharge rests left inside the vessel with help of water.

After clean-up with sponge and liquid detergent mixing apparatus and container should be rinsed thoroughly with plenty of water.

Do not use **CHEMICAL CLEANING AGENTS** like hydrochloric acid and abrasive materials during cleaning.

## **2. CLEAN-UP:**

Periodic maintenance should be carried out by a technician. It is recommended to carry out maintenance at least every 6 months, depending on the frequency of use. Periodic maintenance conducted by authorized service personnel of ours is charged, even the guarantee period has not expired.

## **LIFE OF USE**

Devices life of use is 10 year if it is used under recommended conditions.

# TROUBLE SHOOTING

Trouble	Probable Cause	Corrective Action
Motor doesnt run	Main fuse may be blown	Check the main fuse and switch on it and ensure electricity on.
	Upper lid switch may be broken	When the upper lid closed, it pushes the switch pin. Check the switch. Clean it in case of stucked by means of dirt.
	Upper lid may not be closed properly.	Check upper lid and close properly.
	Peeler disc may be stucked.	While potato pouring from bag into the machine, stone or hard materials can be drop into the peeler disc. This is harmful for machine and it makes disk stucked. Stop the machine, clean the peeler disc and take stucked materials.
	Thermal fuse may be blown.	Check the thermal fuse and reset it incase of its blown.
	Timer or buttons may be broken.	Check them. In case any fault, technical service should replace them with new ones.

# TROUBLE SHOOTING

Trouble	Probable Cause	Corrective Action
Water leakage from filter	Drainage may be obstructed	Clean it and ensure it is not obstructed
	Drainage hose may be bend	Drainage hose has to allow that waste food materials can flow inside properly. Slope of the drainage line has to be downwards.
	Drainage point might have been placed above from filter's bottom surface.	Drainage point has to be placed on the floor.
	Filter may be full or filter holes may be obstructed	Filter drawer has to be cleaned frequently. Take the drawer out and clean also filter bottom surfaces frequently.
	Machine might have been placed on the unstraight place	Machine should be placed on the straight place
	Main drainage may be obstructed	Check and clean it.
Machine doesnt peel potatoes properly	Amount of potatoes might have been too much for the machine.	Potatoes shape, size and amount can affect peeling quality. Decrease the amount of potatoes.
	Silicon carbide coated surfaces may be worned.	Do not throw stones and materials except from potatoes. Replace with new ones.

# TROUBLE SHOOTING

---

Trouble	Probable Cause	Corrective Action
Water leakage from front lid	Front lid might have not been closed properly.	It is normal. Check and close it properly.

# TERMS OF WARRANTY

---

- 1- Documents without sales date, factory and sales company approval on, are not valid. In order to benefit from the warranty, warranty document should be presented.
- 2- If the appliance is installed and operated following the instructions in the installation, maintenance and user's manual, it is warranted for failures sourcing from materials and workmanship .
- 3- The failures within the scope of warranty, how and where these will be eliminated, and the way and place of maintenance is determined by .....
- 4- The warranty is only valid provided that the warranty terms and the instructions in the installation, maintenance and user's manual are fully complied with. The warranty is only valid for the warranted appliance, and no other right or compensation for some other thing may be claimed.
- 5- If the information about the kind and the type of the appliance, serial numbers printed on the warranty document are scraped, rubbed or changed, then the warranty is not valid.
- 6- The warranty covers only maintenance and repairing of material or workmanship failure within the valid warranty period. Failures and parts within the scope of the warranty are repaired and replaced without any charge. Replaced parts belong to .....
- 7- The failures occurring in the appliance may only be handled by service personnel authorized by ..... If people who are not authorized handle the appliance, it will not be covered by the warranty.
- 8- Installation should be carried out by authorized service personnel and the service should be informed about the location change of the appliance.
- 9- When any failure occurs during operation, authorized service dealer should be contacted.
- 10- Warranty does not cover failures and damages resulting from loading, unloading and shipping, which are outside the responsibility of ..... Similarly, failures and damages resulting from external factors are not covered.



GGM Gastro International GmbH  
Weinerpark 16  
D-48607 Ochtrup

[www.ggmgastro.com](http://www.ggmgastro.com)

[info@ggmgastro.com](mailto:info@ggmgastro.com)

+49 2553 7220 0