

# USER MANUAL

## CHICKEN ROTISSERIE, GAS



**GHGK210** Chicken Rotisserie, Gas, 2 spits, 10 Birds Capacity

**GHGK315** Chicken Rotisserie, Gas, 3 spits, 15 Birds Capacity

**GHGK420** Chicken Rotisserie, Gas, 4 spits, 20 Birds Capacity

**GHGK525** Chicken Rotisserie, Gas, 5 spits, 25 Birds Capacity

**GHGK630** Chicken Rotisserie, Gas, 6 spits, 30 Birds Capacity

## Mounting and Connecting

**These instructions are valid if only country code seen on appliance.**

**If country code does not exist on appliance, please refer to valid technical documents in order to arrange appliance in accordance with the technical requirements of the country of use.**

### Electric Connection



- Electric connection of the appliance must be performed by qualified electrician. This electrician should be aware of rules and additional sanctions imposed by local power distribution companies in your country and must strictly observe such rules and additional sanctions.
- Electric connection of the appliance must be performed by authorized and qualified electrician in accordance with EN 60335 standard. Voltage AC 230 V / 50Hz
- Make electric connection of your appliance in compliance with EN 60335-1 and EN 60335-2-38.
- Ground your appliance in compliance with EN 60335-1 standards and ensure maintenance of the grounding.
- Electric safety of the appliance may be ensured only by means of protected cable system in accordance with the rules. It is very important to perform this essential safety measure. If you are suspicious, you have the installation controlled by a professional electrician. The manufacturing firm is not responsible for any damages that may arise from a missing or broken fuse cable or wrong or insufficient electrical installation.
- When performing electric connection of the appliance, never use an extension lead. Appliance safety cannot be realized with extension lead.
- Do not use your appliance in multi-plug socket media.
- Before installation of your appliance, make sure that there is no visible damage. Do not install or use any damaged appliance.
- Before connection of your appliance, make sure that the data on the manufacturer's plate comply with the data of your main electrical circuit ( fuse, voltage and frequency). If you hesitate, please consult a qualified electrician.
- If the main cord is damaged, it must be replaced by an authorised technical service of Supplier.

## Electric Circuit Diagram

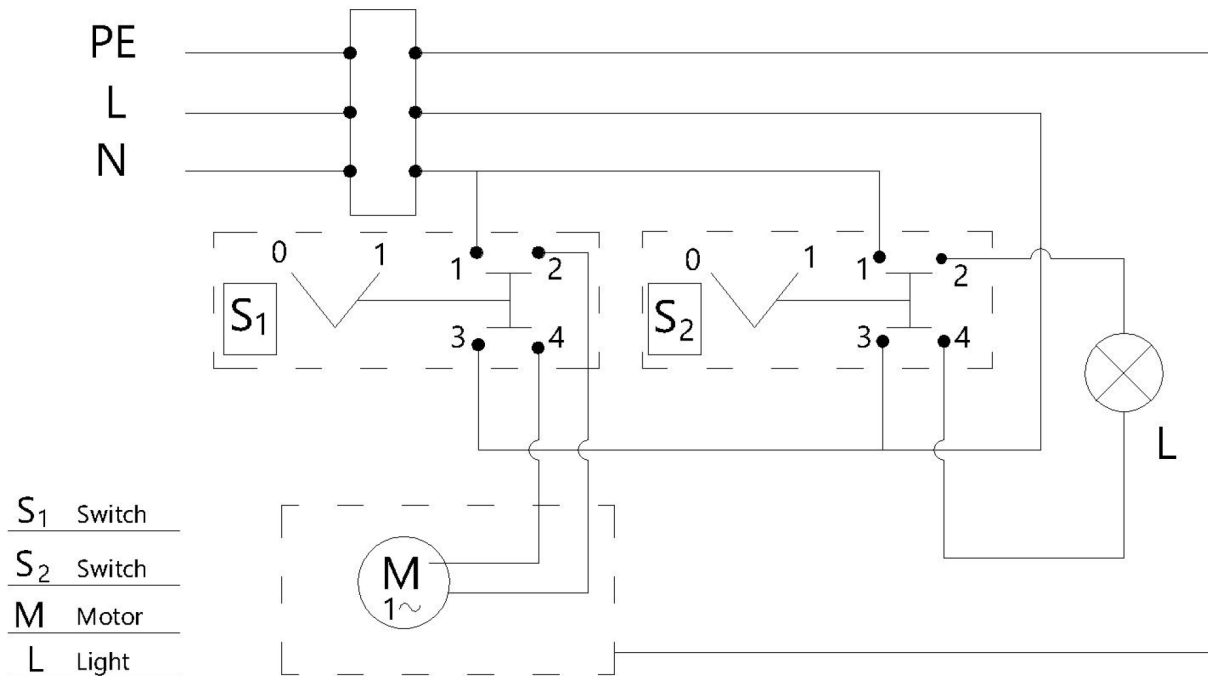

## Gas Connection

- Gas connections of the appliance must be made by qualified gas technician. This gas technician should be aware of rules and additional sanctions imposed by local power distribution companies in your country and must strictly observe such rules and additional sanctions.
- Before gas connection of the appliance, check if local gas distribution requirements (type and pressure of the gas) and adjustment of the appliance are appropriate.
- Ensure that gas connection of the appliance is done in accordance with valid standards and regulations.
- While installing it, never squeeze gas hose under its frame. Keep gas hose away from heated parts of the product.
- Connect your appliance to LPG tube or Natural Gas supply valve as and close as possible and connection must be leak-proof
- While checking gas leakage, make sure if the buttons of appliance are set to "off" position and the tube (or natural gas supply line) is on. To check the gas leakage, cover connector of the hose with foam. If a gas leakage is exists, bubbles shall occur. Check gas leakage again.
- While checking gas leakage, never use fire.
- Particularly while using LPG Gas, ensure that any other relief valve is not assembled other than a relief valve having features specified for the appliance.
- Defective parts may only be replaced by original spare parts. We as manufacturer may only assure you that you shall operate your appliance with these parts completely in safe.
- The manufacturing firm is not responsible for any damages that may be caused by improper mounting or connection of the appliance.

## Rules of Operation

- Please read carefully the Operation Manual before first operation. Thus you shall both protect yourself and prevent the appliance from being damaged.
- Use the appliance only in mounted state. Thus you will avoid of contact with electric-conducting parts of the appliance.
- Use the appliance only under a hood and on a flat surface. The distance between the hood and appliance must comply with the valid local fire and safety regulations in order to get sufficient air ventilation.
- Please bear in mind that if some other appliances used at the same time at the same place together with this appliance, negative effects such as heat, fat, vapour etc. caused by other appliances may result in breaking warranty of the appliance.
- Use the appliance only for grilling poultry, specifically Chicken.
- The appliance must be used by only trained personnel who already read these installation-operating-maintenance instructions respectively.
- The manufacturing firm is not responsible for any defect or damage arising from use of the appliance for any other purpose.



## Protecting Appliance against Damage

- While installing the appliance, protect On-Off Keys from strokes.
- Do not slide "Moving Body Frame" forwards and backwards fast and sharply.
- Caution: Since surfaces of Moving Body Frame, Sword, Above-Sword Lock Mechanism and Sledge Profile are hot, there is a risk of burning! Clean this area after it is cool.
- Prevent any metal and similar parts entering into the ventilating openings on the appliance body as they may give damage to the gas fittings and electric parts.
- Caution: Operating gas pressure of the appliance is given on the label of appliance.
- There is a risk of gas leakage when operating in higher pressure.
- Immediately clean any dirt that may occur on the surfaces of the appliance to prevent them from burning and sticking on the surface.
- Never use pressure water and steam cleaning tools. Such cleaning materials may give damage to the appliance.
- When moving the appliance, wrap it up with folio for protection against dust.

## Troubleshooting

Problem	Possible Cause	Solution
* Appliance does not heat or burners do not operate	* Inlet Valve connected to inlet of the appliance is closed.	* Open the Inlet Valve
	* Burner is out of order * Burner Gas Supply Valve is faulty	* Please contact our Customer Service Team.
* Motor does not work	* The switch of motor is out of order * Motor is faulty	* Check the main fuse. * Turn the switch of motor "off". * Unplug the appliance. * Turn the all switch off. * Please contact our Customer Service Team.

## Customer Service

**Service operation is performed at the plant facility.**

### Service / Factory Address:

GGM Gastro International GmbH  
Weiner Park 16 48607 Ochtrup Germany

Internet: [www.ggmgastro.com](http://www.ggmgastro.com)      [www.ggmgastro.de](http://www.ggmgastro.de)  
E-Mail: [info@ggmgastro.com](mailto:info@ggmgastro.com)

### Germany:

**Tel.:** (0049)-02553-7220-300  
**Fax:** 02553 - 7220 - 200

## Things to be done before First Operation



### Transportation and Storage



- If you need to transport the appliance, then move it in its original container and comply with the movement marks on the container.
- If the original container of the appliance is not available, fix the moving parts (Sword (or spits), fixing handle, Moving Body Frame and Oil Drawer) by using an adhesive tape.
- Take necessary protective measures against possible strokes to Switch On/Off knobs, Cable Outlet Sleeve and Relief Valve Connection Sleeve, and other surfaces. Do not put any load on the appliance heavier than its own weight.
- Keep the product in normal position during movement.
- If the appliance shall not be used or kept for sale for extended time, store it indoor in dry, dust and damp free conditions.

### First Cleaning and First Heating

- Before first operation, remove nylon film on your appliance and wipe inner and outer parts with a damp cloth and then wipe dry.
- Do not use detergent for wiping operation.
- A temporary odour and smoke may occur at the heated parts of your appliance during first heating.
- Odour and any possible smoke shall disappear soon. Odour and smoke do not indicate incorrect connection or defective appliance.

## Operation

### Switching On/Off

- Turn on Shut-off valve of the gas line or tube.
- Start ignition from the top burner and then ignite other burners from top to bottom respectively.
- Press and Turn the top knob to the high flame setting and ignite with a lighter.
- Hold the knob pressed for 10-15secs.
- Large flame sign “” means “normal burn”, and small sign “” means “low burn”.
- To turn the knob “off” position, turn it to “O” position, and release it.

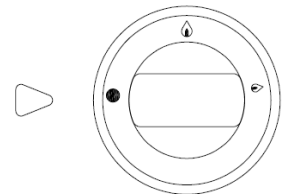

### Warning sign



Warning



Hot



Glove



Upwards



Potential Grounding



Fragile



Protect from humidity



Grounding



Electric

## Technical Specification

ÜRÜN KODU	KAPASİTE ( Piliç Adedi)	TÜKETİM ( m3/h )	GÜÇ ( kW )	Ağırlık kg	EBATLAR genişlik x derinlik x yük. ( mm )			Doğalgaz ile Kullanımda Uygun BASINÇ mbar	LPG ile Kullanımda Uygun BASINÇ mbar
CODE NR.	Capacity Bird Qty.	Consumption ( m3/h )	Power ( kW )	Weight kg	Dimension width x depth x height ( mm )			Pressure when used with Natural Gas mbar	Pressure when used with Propan Gas mbar
GHGK210	8-10 piliç/birds	0,98	9,40	65	1150	472	605	21 mbar	50 mbar
GHGK315	12-15 piliç/birds	1,46	14,10	85	1190	472	793	21 mbar	50 mbar
GHGK420	16-20 piliç/birds	1,96	18,80	100	1190	472	981	21 mbar	50 mbar
GHGK525	20-25 piliç/birds	2,44	23,50	140	1190	472	1169	21 mbar	50 mbar
GHGK630	24-30 piliç/birds	2,94	28,20	160	1190	472	1357	21 mbar	50 mbar

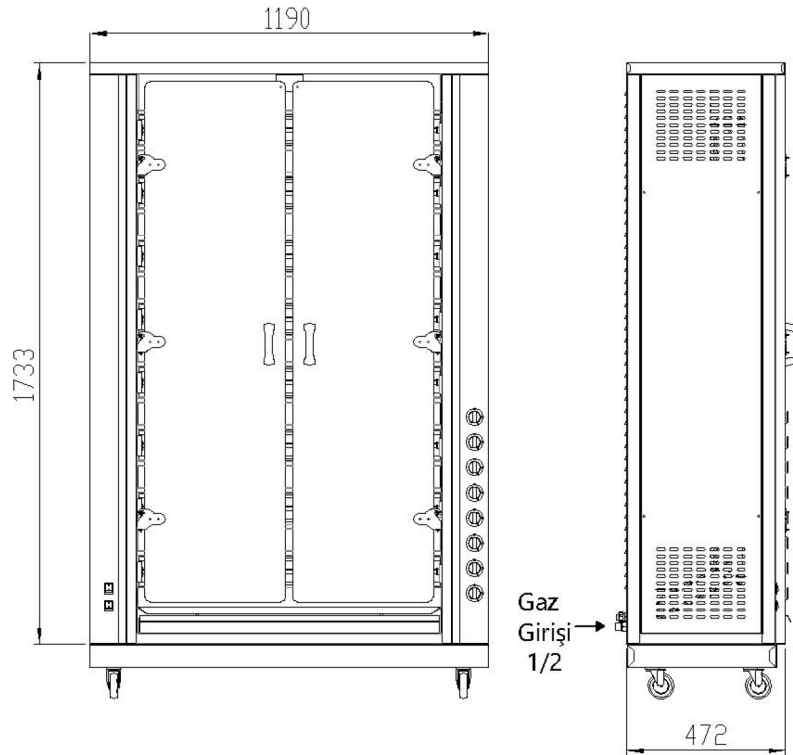

Exploded View

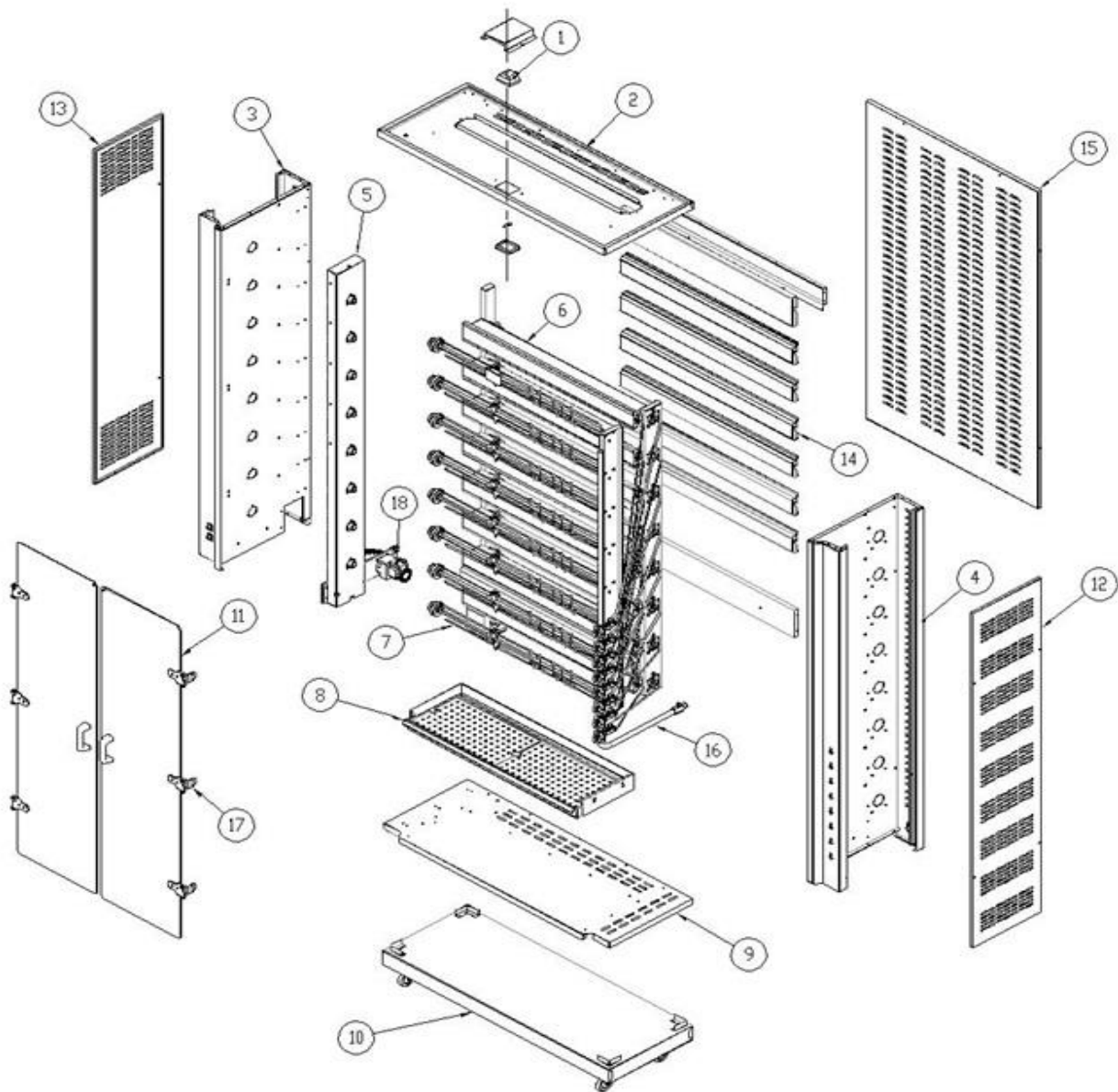

NO	PARTS NAME	PCS
1	LAMP GROUP	1
2	TOP HOOD	1
3	LEFT PANEL	1
4	RIGHT PANEL	1
5	CHAIN SET	1
6	BURNER	3
7	SKEWERS	3
8	FAT TRAY	1
9	BOTTOM PANEL	1

NO	PARTS NAME	PCS
10	CASTERS & TROLLEY	1
11	GLASS DOOR	2
12	RIGHT PANEL COVER	1
13	LEFT PANEL COVER	1
14	BURNER MID. COVER	2
15	BACK COVER	1
16	GAS COLLECTION GROUP	1
17	HINGE	4
18	MOTOR	1

### Stainless Separator Plates Between Burners Take out/Put back

Stainless Separator Plates Between Burners could be Taken out and Put back easily by pushing simply with the tip of your finger from the top part as seen at the below picture.

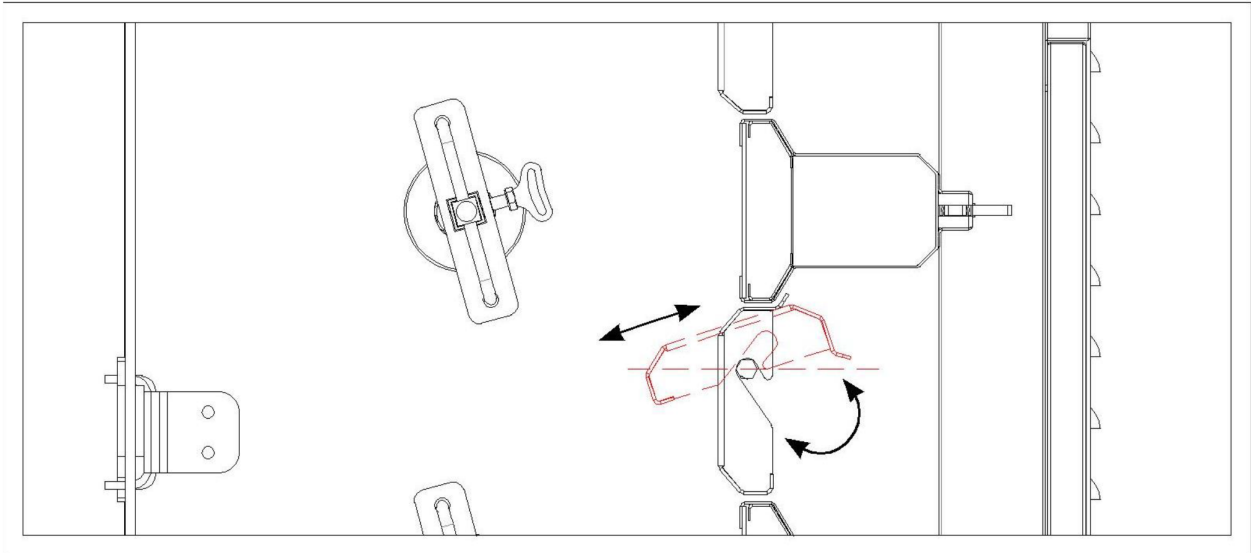

### Burners Take out / Put back

- Take out the Stainless Separator Plates Between Burners as explained above.
- Burners could be taken out by simply pulling the trigger shaped knob on the left back side of each burner as shown below Picture.

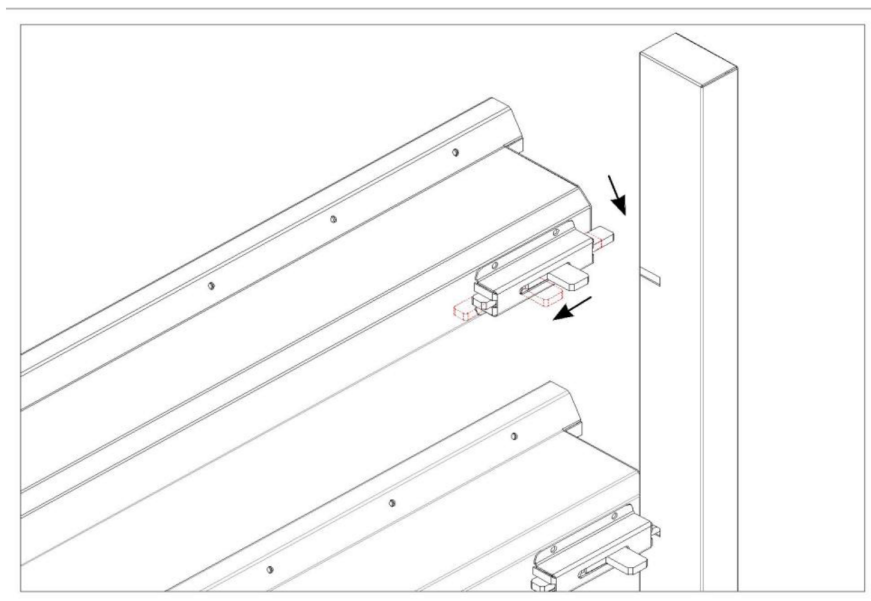

## Bulb Replacement

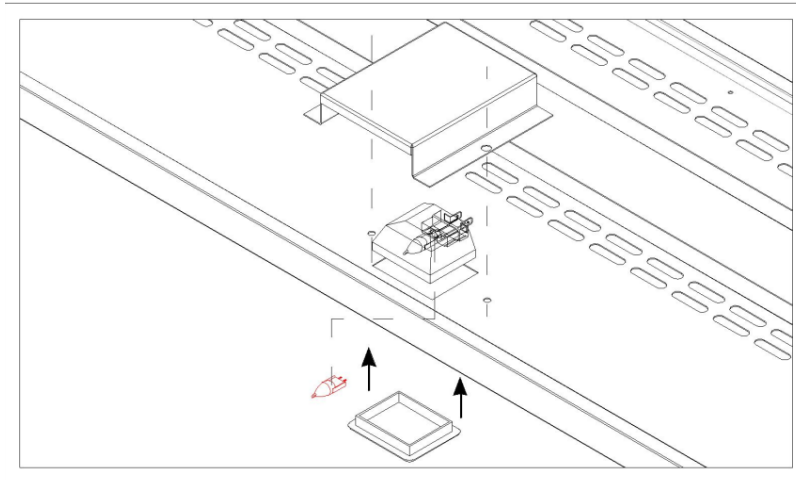

## Injector Replacement

- Dismantle Radian Gas Supply Pipe-Valve Connection Sleeve (Figure 1,2,3).
- Dismantle current injector, and insert a new injector appropriate to gas system intended to use instead of it (Figure 4).
- Similarly, fix Gas Supply Pipe in its place.
- Check gas leakage of Valve Connection Sleeve by soap foam. Never do gas leakage check with fire (match).

	G-20 20mbar	G-20 25mbar	G-25 20mbar	G-25 25mbar	G-30 30mbar	G-30 37mbar	G-30 50mbar	G-31 37mbar	G-31 50mbar
<b>Injector</b>	<b>1,65</b>	<b>1,55</b>	<b>1,80</b>	<b>1,70</b>	<b>1,10</b>	<b>1,05</b>	<b>0,95</b>	<b>1,05</b>	<b>0,95</b>

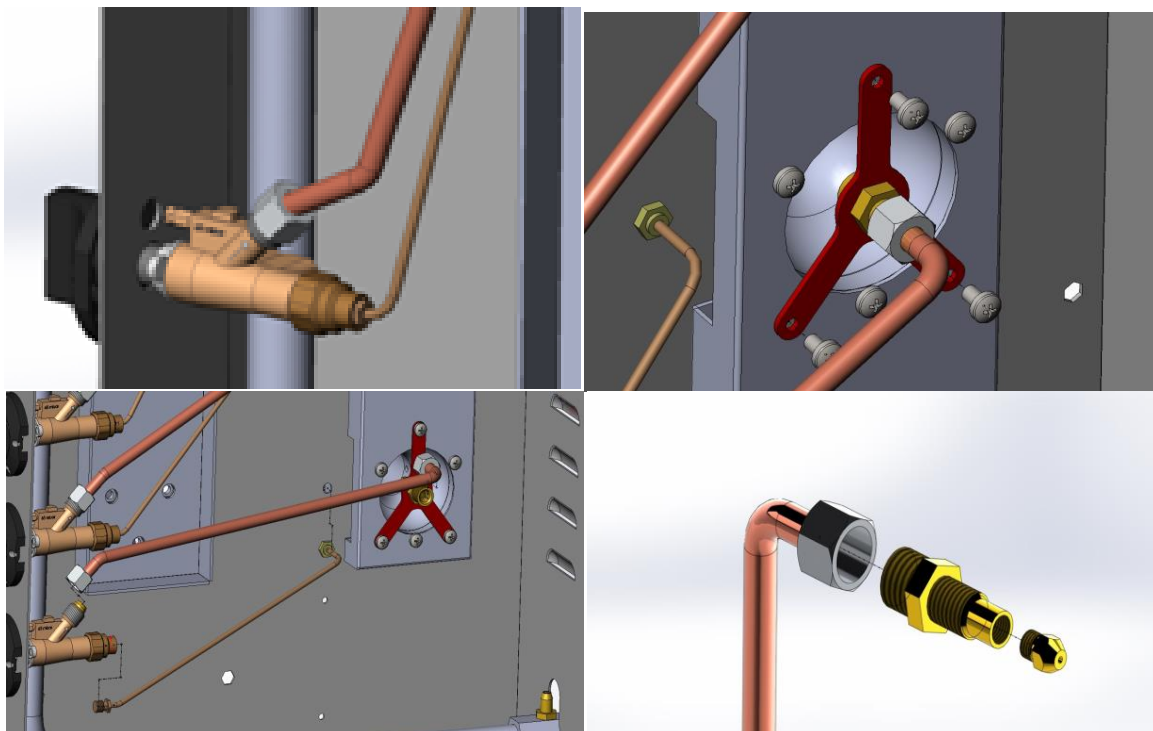

## WARRANTY

The appliance is guaranteed for 1 (ONE) year from the date of delivery of the appliance against defects in production, workmanship and assembling only if appliance is used in accordance with the instructions written in user manual and repaired only by a service person authorized by manufacturer or seller.

This guarantee is only valid if all the instructions, obligation and responsibility written for user in user manual and this form followed by user.

Our company is free to choose the repair methods to be applied and determination of replacement parts.

Repair places are authorized service workshops or our factory. Guarantee procedures only starts after reporting of fault and deliver the product to these repair places.

All transport, cargo, and related expenses occur when sending the appliance to our authorized service workshops or to our factory for repair and from our authorized service workshops or factory to customer after the necessary repairs and also possible damage that may occur during shipping have to be covered by the customer.

This warranty does not cover damage arising for misuse of the appliance as well as following points;

This warranty does not cover damage arising because of user mistakes.

This warranty does not cover damage arising during transportation, installation or while moving the Product, or to any transportation costs of the Product or any parts thereof to and from the owner, unless otherwise specified in these warranty conditions.

The warranty will not apply if damage, malfunction or failure resulting from use on an incorrect voltage, power surges and voltage dips, voltage supply problems, use of defective or incompatible accessories, failure to ground, exposure to abnormally corrosive conditions or foreign object in the Product.

The warranty will not apply if damage, malfunction or failure resulting from fire or thunderstorm activity,

The warranty will not apply if damage, malfunction or failure resulting from alterations, accident, misuse, abuse, damaging synthetic chemical liquid spillage, improper installation or operation, lack of reasonable care, loss of parts, tampering or attempted repair by a person not authorized by manufacturer or seller.

The warranty does not cover normal wear of the Product or parts and the parts that could be used as spare parts.

The warranty will not apply if damage, malfunction or failure resulting from use against the instructions written in user manual and repaired only by a service person authorized by manufacturer or seller.

The warranty will not apply if the factory-applied serial number has been altered or removed from the Product.

The responsibility of perfection and giving the warranty to customer belongs to seller, dealer or agent who sells the appliance to the customer.



GGM Gastro International GmbH  
Weinerpark 16  
D-48607 Ochtrup

[www.ggmgastro.com](http://www.ggmgastro.com)      [info@ggmgastro.com](mailto:info@ggmgastro.com)  
+49 2553 7220 0