

**EHFMY535**

# **Countertop Pressure Fryer**

## **INSTRUCTION MANUAL**

Read this manual carefully prior to use.

Technology is subject to change without notice.

## The Brief Introduction of Capacity of Commercial and Electric pressure fryer

The countertop pressure fryer EHFMY535 is a new product that very popular in the European and American markets. This product has been declared National patent recently. It is characterized by small size, high capacity, easy operation, and high efficiency, but also to save electricity; it can be used with a general power of lighting. But the electric power of the electric pressure fryer is very big in current market; it must be use with large-capacity three-phase, also has heavy volume. The product has ordinary fryer's inherent properties of devices, but also has no explosive device, Adopt a flexible beam supporting device, the pressure inside the pan is overpressure when the work valve is jammed, the beam will pop-up automatically, the steam inside the pan will decompression from the around of the pan, thus ensuring that there was no risk of explosion pot. The electric heating adopts temperature control structure and timing overheating protection device. The valve which put oil has chain protect by bolt, it has high degree of reliability and safety performance. It is a new international product which is necessary equipment of guest houses, hotels, restaurants and leisure snack bar.

### Main technical parameters

Specified voltage: ~220V	overall size: 350*400*500
Specified power: 3kw	weight: 18kg
Work pressure: 8psi	Control temperature:50-300°C
Capacity: 16L	Regular time: 0-30''
Heater: ceramic	

## CLEANING THE POT AND CABINET

The inside of the fryer should be cleaned daily. If left, oil and breading deposits can become burnt on and be very difficult to clean.

To clean the pot fill the fryer 3/4 full with water and add washing up liquid. Clean the inside with a stiff bristle or a stainless steel scouring pas while the pot is still warm.

Caution. Do not leave the heat switched on or the contents will boil over.

Beware in using chemical cleaners that they are suitable for use with aluminums.

Corrosion can occur with many products.

Particularly those containing caustic soda.

We can not accept responsibility for damage caused by the use of corrosive cleaning products.

Care should be taken to keep the drain free of debris. Ensure that the drain calve is fully open before cleaning the drain to avoid damaging the ball valve or its seals.

Be careful to remove all the water and any remains of cleaning materials before use.

Clean the outside of the cabinet with a damp cloth and detergent. Abrasive cleaning products such as wire wool and scouring pads will scratch the finish.

Kuroma is designed to be splash proof. On no account use a water jet or a steam jet on the cabinet. If it suspected that the control circuit has been affected by water, switch off at the control circuit has been affected by water, switch off at the mains, and remove the 13amp plug from its socket, and leave the fryer in a warm place to dry out.

Have the cooker checked over by an electrician before reconnecting.

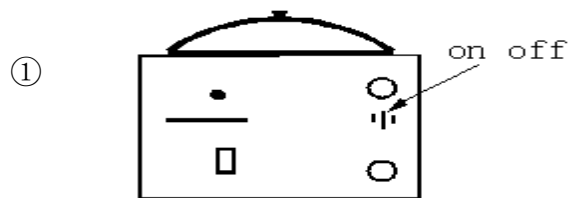

Plug fryer in and switch on. The red mains lamp should light. Switch off, do not leave heat on with fryer empty.

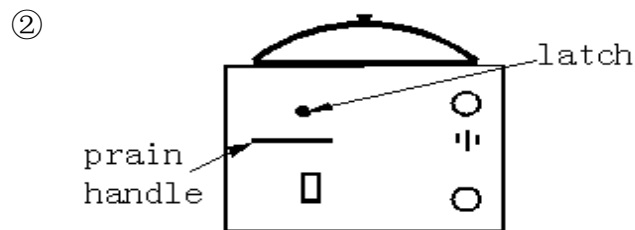

If the red lamp does not light, check that the drain handle is closed (fully left) and the latch is down, and try again.

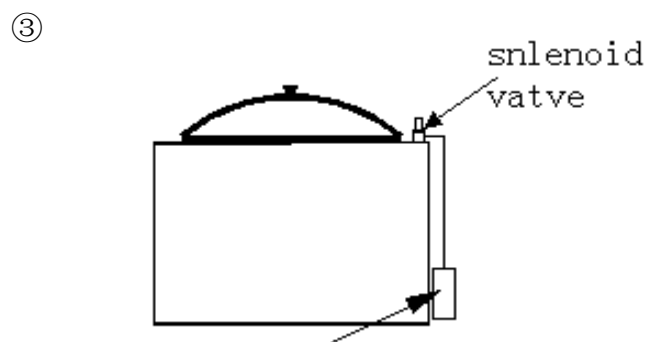

Place a small container under the outlet pipe at the back of the machine to catch any steam and water expelled when cooking finishes.

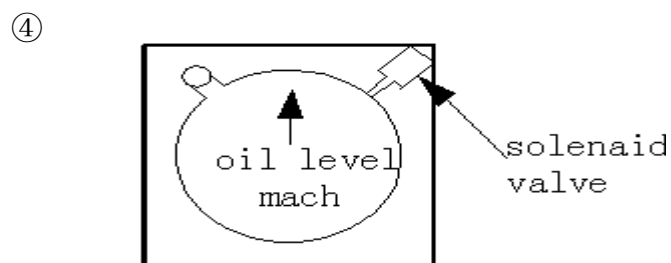

Now fill the pot with oil up to the oil level mark on the inside of the pot.  
**DO NOT OVERFILL WITH OIL**

⑤

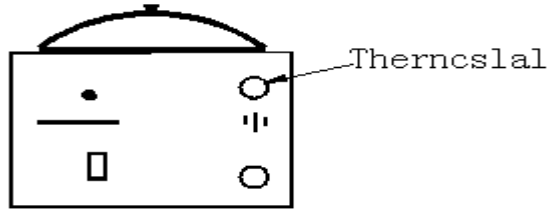

Switch on and set thermostat is 7. The amber lamp will light. Heating from cold may take 30 minutes.

⑥ while the oil is heating dip the chicken pieces in water and roll in seasoned bread mix.

The breading mix sticks better if done at least 20 minutes before frying.

⑦

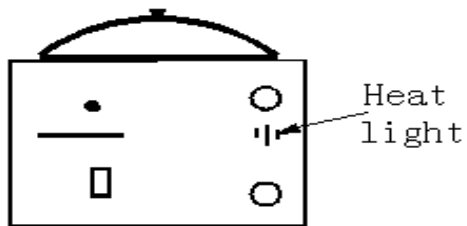

When the oil has reached the correct temperature the amber heat lamp will go out.

⑧ take your previously breaded chicken and roll again in breading mix. Do not re-wet the pieces this time.

Shake off any excess breading and place in the fryer one piece at a time.

⑨ DO NOT OVERFILL WITH CHICKEN.

DF – 10 to 12 pieces maximum

XL – 15 pieces maximum

MF – 18 pieces maximum

⑩

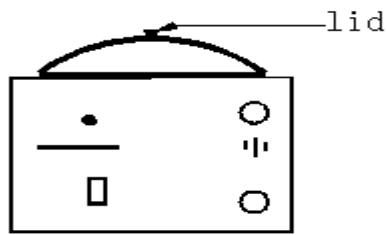

Replace the lid ensuring it is fitted squarely and tighten the lid knob 2 full turns of the lid knob should be enough.

⑪

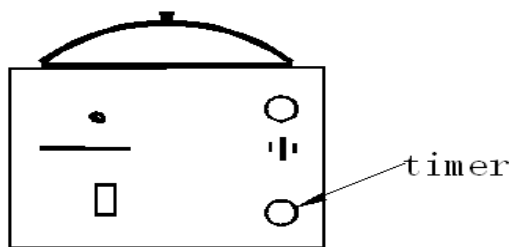

Set the timer on the front panel to the required time. You may hear a click as the safety valve closes.

⑫

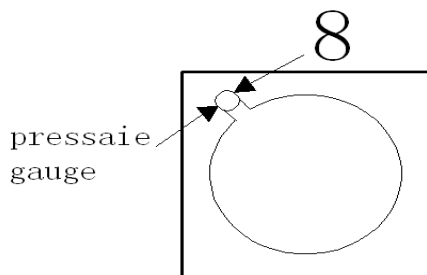

Pressure will now build up in the pot. The normal running pressure is 8 psi.

⑬ While the chicken is cooking the spinning dead-weight valve on the lid will vent any excess steam. This valve must be kept clean at all times. If the valve becomes blocked the spring loaded lid will lift to release excess pressure at about 16 psi on the gauge.

⑭ check that the lid has been fitted correctly and that steam is not leaking from around the edges.

The heat light will go on and off while the oil is brought back up to temperature.

(15) when the timer has run down to zero the solenoid valve will open and steam will be ejected into your container. Wait until the pressure has fallen before removing the lid.

(16) remove the frying basket clear of the oil and allow the chicken to drain.

(17) the heating light will probably now be on as the oil is reheated to frying temperature. Wait until this goes out before reloading the machine.

(18) CHANGING THE OIL

To open the drain valve you must first unlock it by lifting the red catch. This will automatically switch off the machine ensuring that oil cannot be drained whilst the pot is under pressure.

(19) if no oil is released when drain opened. Try stirring the sludge at the bottom of the pot.

It is advisable to wait until the oil is cool before draining.



GGM Gastro International GmbH  
Weinerpark 16  
D-48607 Ochtrup

[www.ggmgastro.com](http://www.ggmgastro.com)      [info@ggmgastro.com](mailto:info@ggmgastro.com)  
+49 2553 7220 0