

COMMERCIAL SLUSH MACHINE SERIES PRODUCT INSTRUCTION MANUAL

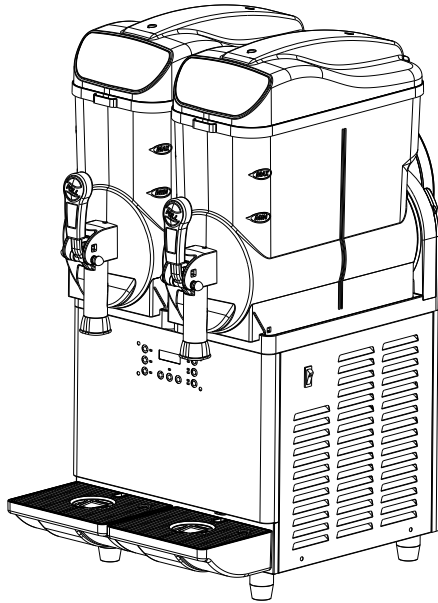

This is the original instruction, Please read all manual instructions carefully before operating. reserves a clear interpretation of our user manual. The appearance of the product shall be subject to the product you received. Please forgive us that we won't inform you again if there are any technology or software updates on our product.

Content

1. Explanation of warning diagrams	03
2. Operation safety Instructions	05
3. Operation Instructions	08
4. Machine Operating Instructions.....	08
5. Cleaning and Maintenance	13
6. Assembly of parts	17
7. Condenser cleaning	19
8. Circuit schematic	19
9. Environmental Protection List	21
10. Product Specifications	23
11. Troubleshooting Instructions	24

Please read this Manual carefully before use.

The company reserves the right of interpretation for the Manual.

The appearance of the product is subject to the actual product.

Please keep it together with the invoice.

We will not notify you of any product technology or software upgrades.

Explanation of warning diagrams



Prohibition Signs

Indicating a prohibited act that may cause fatal or serious injury.



Warning Signs

Indicating the matters needing attention that may cause personal injury or damage to objects.



Dangerous Voltage

Indicating a high voltage danger zone, beware of high voltage.



Fire Hazard

Indicating that the material used is flammable. beware of fire.



Note: Be sure to keep this manual in a place where users can access it at any time.

Safe Handling Precautions



WARNING

When the machine has just arrived, leave it quietly for 24 hours to precipitate the lubricating oil of the compressor before it can be used, otherwise the compressor will be easily damaged.



Do not use this Slush Machine in the open air. When the machine is drenched by rain, it may cause electric leakage or electric shock.



Never place this Slush Machine in a wet place or where it is vulnerable to water splashing. Damage to the insulation material of this Slush Machine may cause electric leakage or electric shock.



Never spray water directly on this Slush Machine. A wet Slush Machine may cause electric shock or short circuit.



Be sure not to put volatile or flammable substances into the Slush Machine bucket. Containers or places where such substances are stored may cause explosions or fires.



Only qualified engineers or maintenance personnel should install this Slush Machine. Installing this Slush Machine by yourself may cause gas or liquid leakage, electric shock or fire.



Do not use this Slush Machine in the open air. When the machine is drenched by rain, it may cause electric leakage or electric shock.



Never ground the Slush Machine through a gas pipe, water main, telephone line or lightning rod. This is considered unsafe grounding.



Never insert metal materials such as iron needles or wires into vents or vents used for air circulation in the machine. This may cause electric shock or personal injury due to the accidental operation of the moving parts.



Be sure to place the Slush Machine firmly on solid ground. If the ground is not strong enough or is not firmly placed, it will cause damage due to the overturning or capsizing of the Slush Machine.



Be sure to use the consistent special power supply on the nameplate of this Slush Machine. Using branch sockets will cause fire.



Be sure to plug the power plug firmly into the socket after removing the dust. Dusty sockets or incorrect insertion may cause fire.



Use a grounded socket to prevent electric shock. In case there is no grounded socket, the grounding device must be assembled by qualified engineers and technicians, and the socket should be located in an easily accessible position after installation of the slush machine.



Do not use places with a lot of sulfuric acid, such as hot springs, or places with a lot of salt such as bays. Otherwise, it may cause internal corrosion and cause machine failure.



This device has flammable materials, and when it is discarded, it must be disposed of and recycled by qualified personnel and institutions.



Do not trample on this machine or hang or place heavy objects on the machine. Otherwise, it may damage the machine and cause injury to people.



Do not damage the cooling circuit.



Please use the new hose assembly that comes with the appliance. The old hose assembly cannot be reused.



When any malfunction occurs with the Slush Machine, please unplug the power plug. If the abnormal operation is continued, it may cause electric shock or fire.



When dealing with toxic, harmful or radioactive materials, please use this Slush Machine in a safe place. Incorrect use may have adverse effects on your health and environment.



Do not damage the power cord, or damage it, process it, assemble it into bundles, stretch, bend or twist it reluctantly. Otherwise, the power cord may be damaged, causing electric shock or fire accident.



There is no obstruction around the appliance or in the embedded structure to keep the ventilation open.



Before cleaning, maintaining or inspecting the Slush Machine, unplug the power supply to prevent electric shock or personal injury.



If some models use combustible refrigerants and flammable foaming agents, you should beware of fire (there is a " Fire Hazard  " sign on the product). When the product is abnormal, it must be repaired by relevant qualified personnel and institutions.



This machine is not intended for use by people with physical weakness, slow response or mental disorders (including children), except with the guidance or help of a guardian. Children should be supervised to ensure that they do not play with machines.

Operation Safety Instructions

Electrical Safety Precautions

1. Please refer to the famous brand for the use voltage of the Slush Machine. If the voltage is not in this range, please purchase a voltage regulator of more than 2000W by yourself.
2. Please be sure to connect the ground wire, and the safe ground wire can not be connected to the water pipe or gas pipe.
3. In order to protect the compressor, please do not start the Slush Machine again within ten minutes after the power outage.
4. Please do not connect other electrical appliances to the same socket.
5. This appliance can be used by children aged from 8 years and above and persons with reduced physical, sensory or mental capabilities or lack of experience and knowledge if they have been given supervision or instruction concerning use of the appliance in a safe way and understand the hazards involved. Children shall not play with the appliance. Cleaning and user maintenance shall not be made by children without supervision.
6. The electric control system has a voltage of more than 36V, please do not open and touch it at will when in use. If you need maintenance, please contact the manufacturer or ask the relevant qualified technical personnel to deal with it.
7. If the supply cord is damaged, it must be replaced by the manufacturer, its service agent or similarly qualified persons in order to avoid a hazard.

WARNING: Do not operate the slush machine when there is a gas leak in the environment where the slush machine is located. Sparks caused by unplugging or start-stop control may cause a fire, so you should cut off the power first, open the windows, and let the air circulate.

Installation Precautions

Requirements for handling and moving conditions:

When handling, try to keep the box upright, the maximum inclination is not more than 45 °, do not invert and put horizontally.

To operate the Slush Machine correctly and get the best performance, please put the Slush Machine where the following conditions are met.

1. Solid and flat ground.

To operate the Slush Machine correctly and get the best performance, please put the Slush Machine where the following conditions are met.

2. Stay away from the place where the heat source is generated.

Avoid putting Slush Machines near heating equipment, such as gas flames or stoves. The heating of the Slush Machine will lead to a decrease in cooling efficiency.

3. Avoid direct sunlight.

If the Slush Machine is installed in direct sunlight, it may cause abnormal work and shorten the working life of the Slush Machine.

4. Dry area.

Avoid placing Slush Machines in wet areas, such as near faucets or sinks.



Install a disconnect switch



If the Slush Machine is placed in a wet area, a circuit breaker must be installed and the Slush Machine must be grounded. Install the circuit breaker in the power line. For further information, please consult the Slush Machine retailer or electrical technician.



If the Slush Machine is placed in a wet area, a circuit breaker must be installed and the Slush Machine must be grounded. Install the circuit breaker in the power line. For further information, please consult the Slush Machine retailer or electrical technician.



Be sure to use a plug with a ground wire structure and ground the Slush Machine to prevent electric shock during leakage.



Replacing grounding terminals with water pipes will not provide correct grounding protection in many cases because plastic pipes are often used in plumbing.



Never ground the Slush Machine through the gas pipe, because it is very dangerous.



Never ground the Slush Machine through telephone lines or lightning protection, because if thunder and lightning occurs, it will generate a large current, which makes this grounding very dangerous.

5. Nothing will fall into the place where the Slush Machine is stored.

Environmental Conditions

This equipment is designed in accordance with the following conditions.

1. Use it indoors.

2. The elevation is no more than 2000 meters.
3. The ambient temperature is in the range of 10 °C–32 °C.
4. When the temperature is not higher than 31 °C, the maximum relative humidity is 80%, and the maximum relative humidity decreases linearly with the increase of temperature.
5. The voltage fluctuation of the main power supply shall not exceed ±10% of the rated voltage.
6. In line with the equipment installation level (overvoltage level) transient overvoltage.

This apparatus is used for similar purposes, such as.

- the kitchen area of a store, office or other workplace.
- customers of farms and hotels, motels and residential environments.
- Family Hotel Environment.

Catering and similar non-retail applications.

This appliance is not used for general household use.

Correct operation

When using it for the first time and running continuously, please follow the following rules.

1. The Slush Machine is connected to a special socket (the power supply is the same as the famous brand).
 2. The Slush Machine is surrounded by a cooling channel for the refrigeration system, so it is forbidden to place articles to block it.
 3. After completing the inspection of the operation of the Slush Machine, turn on the power supply of the Slush Machine and power on the machine.
 4. Please ensure enough space around the Slush Machine to ensure smooth ventilation.
- Don't store any sundries in the bucket.
 - Slush Machine should be far away from the heat source, it is forbidden to use in high or low temperature environment, sDirect sunlight shall be avoided as far as possible to avoid affecting heat dissipation.
 - Do not directly pour water to wash the surface of the Slush Machine, otherwise it may lead to short circuit, leakage and other failures.
 - After the Slush Machine has been in use for a period of time, if it is put out of use for a long time, it should be powered on and run for 4 to 6 hours a month.
 - There should be more than 30cm of space around the slush machine to ensure heat dissipation.

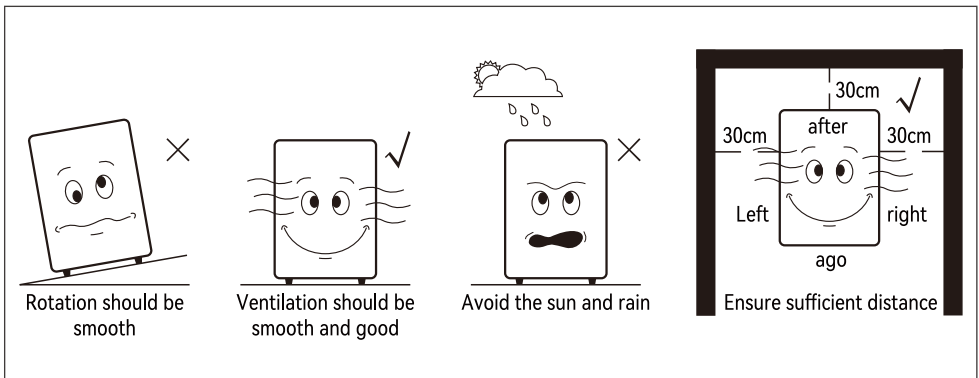

Operation Instructions

For simplicity, this manual takes a single bucket as an example, the operation of other buckets, etc.

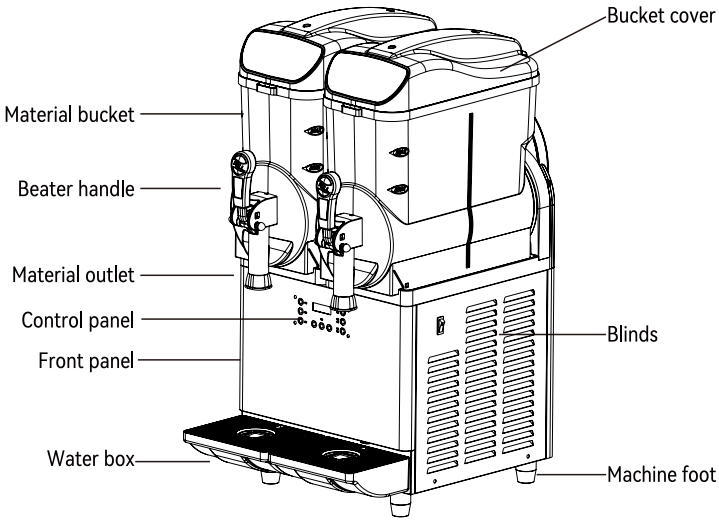

Single Hopper Operation Panel

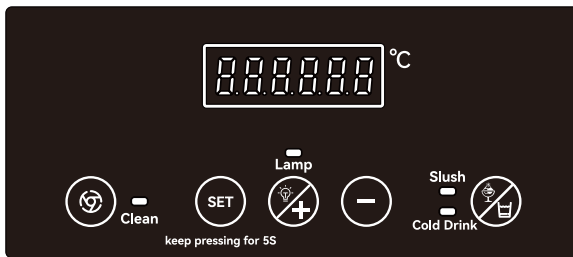

Double Hopper Operation Panel

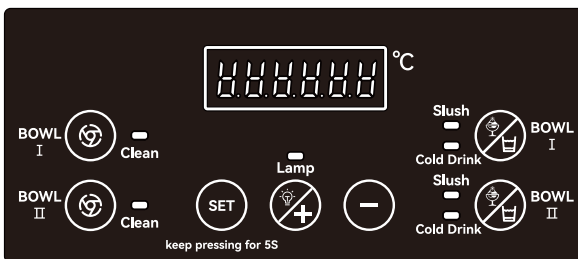

Triple Hopper Operation Panel

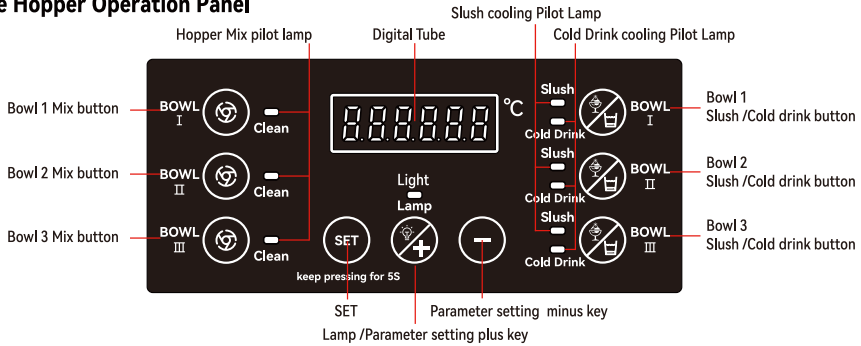

Machine Operating Instructions

Button Operation Instructions

Tank 1 Mixing Button

Function Description:

1. Press the Tank 1 mixing button briefly:
 - Activates the mixing function for Tank 1.
 - The indicator light turns on, and the mixing motor starts working.
2. Press the Tank 1 mixing button again:
 - Deactivates the mixing function for Tank 1.
 - If cooling is already enabled for the tank, the cooling solenoid valve for Tank 1 will also turn of.
 - If the mixing function for the other two tanks is not enabled, the entire cooling system (for cold drinks or slush) will also shut down.

Tank 2 Mixing Button

Function Description:

1. Press the Tank 2 mixing button briefly:
 - Activates the mixing function for Tank 2.
 - The indicator light turns on, and the mixing motor starts working.
2. Press the Tank 2 mixing button again:
 - Deactivates the mixing function for Tank 2.
 - If cooling is already enabled for the tank, the cooling solenoid valve for Tank 2 will also turn of.
 - If the mixing function for the other two tanks is not enabled, the entire cooling system (for cold drinks or slush) will also shut down.

Tank 3 Mixing Button

Function Description:

1. Press the Tank 3 mixing button briefly:
 - Activates the mixing function for Tank 3.
 - The indicator light turns on, and the mixing motor starts working.
2. Press the Tank 3 mixing button again:
 - Deactivates the mixing function for Tank 3.
 - If cooling is already enabled for the tank, the cooling solenoid valve for Tank 3 will also turn of.
 - If the mixing function for the other two tanks is not enabled, the entire cooling system (for cold drinks or slush) will also shut down.

Tank 1 Slush/Cold Drink/Cooling Stop Button

Function Description:

1. Briefly press the Tank 1 Slush/Cold Drink/Cooling Stop button to activate the "slush mode":
 - The slush function for Tank 1 starts.
 - The slush indicator light turns on.
 - The mixing motor operates, and the cooling system is activated.
2. Press the button again to switch to "cold drink mode":
 - The cold drink indicator light turns on.
3. Press the button a third time:
 - The cooling solenoid valve for Tank 1 shuts of.
 - If no other tanks have the cooling function enabled, the cooling system stops entirely.

Tank 2 Slush/Cold Drink/Cooling Stop Button

Function Description:

1. Briefly press the Tank 2 Slush/Cold Drink/Cooling Stop button to activate the “slush mode”:
 - The slush function for Tank 2 starts.
 - The slush indicator light turns on.
 - The mixing motor operates, and the cooling system is activated.
2. Press the button again to switch to “cold drink mode”:
 - The cold drink indicator light turns on.
3. Press the button a third time:
 - The cooling solenoid valve for Tank 2 shuts of.
 - If no other tanks have the cooling function enabled, the cooling system stops entirely.

Tank 3 Slush/Cold Drink/Cooling Stop Button

Function Description:

1. Briefly press the Tank 3 Slush/Cold Drink/Cooling Stop button to activate the “slush mode”:
 - The slush function for Tank 3 starts.
 - The slush indicator light turns on.
 - The mixing motor operates, and the cooling system is activated.
2. Press the button again to switch to “cold drink mode”:
 - The cold drink indicator light turns on.
3. Press the button a third time:
 - The cooling solenoid valve for Tank 3 shuts of.
 - If no other tanks have the cooling function enabled, the cooling system stops entirely.

Illumination Button (Increase)

Function Description:

- Briefly press the illumination button:
 - The “LED light inside the tank turns on”, and the illumination indicator light also turns on.
- Press the illumination button again:
 - The “LED light turns of”.

Setting Button

Function Description:

1. Press and hold the setting button for 5 seconds:
 - The machine enters the user parameter settings mode.
 - The left two digits of the digital display show the parameter code.
 - The right three digits of the digital display show the parameter value.
2. In the settings mode:
 - Press the setting button to switch between diferent parameters.
 - Use the illumination button (Increase) or the adjustment button (Decrease) to change the parameter values.
3. After completing the adjustments:
 - Wait for 5 seconds to automatically exit the parameter setting interace.
 - The new parameter values are automatically saved.

User Parameter Code Table:

(Provide the parameter codes and descriptions here).

Single bowl parameter table

display code	parameter name	Defaults	Setting range
S1	slush in bowl temperature set point	-1.5°C	0°C~-10°C
C1	cold drink in bowl temperature set point	5°C	0°C~10°C

Double bowl parameter table

display code	parameter name	Defaults	Setting range
S1	slush in bowl 1 temperature set point	-1.5°C	0°C~-10°C
S2	slush in bowl 2 temperature set point	-1.5°C	0°C~-10°C
C1	slush in bowl 2 temperature set point	5°C	0°C~10°C
C1	cold drink in bowl 3 temperature set point	5°C	0°C~10°C

three bowl parameter table

display code	parameter name	Defaults	Setting range
S1	slush in bowl 1 temperature set point	-1.5°C	0°C~-10°C
S2	slush in bowl 2 temperature set point	-1.5°C	0°C~-10°C
S3	slush in bowl 3 temperature set point	-1.5°C	0°C~-10°C
C1	cold drink in bowl 1 temperature set point	5°C	0°C~10°C
C2	cold drink in bowl 2 temperature set point	5°C	0°C~10°C
C3	cold drink in bowl 3 temperature set point	5°C	0°C~10°C

Note: When the raw material is a sugar-containing non-alcoholic drink, the slush temperature is set at -1.5 to -2 degrees. When the raw material is an alcoholic drink, the temperature of the smoothies is different for drinks with different alcohol content, so please set the slush temperature in the bowl according to the alcohol content. When the temperature setting is not low enough, the slush cannot be melted into smoothies, and when the temperature setting is too low, freezing cylinders will appear.

Due to the improvement and serialization of the product, we apologize that the product you have obtained may not be completely consistent with the diagram of this manual.

1. Raw material preparation

In a suitable container, dilute the concentrate with water and stir according to the manufacturer's instructions. The sugar content of the mixture should be kept between 13%-18%. Lower and higher concentrations can damage the stirrer and stirrer motor.

The sugar content must exceed 13%.

Due to insufficient sugar, the slush cannot hold its shape. Adding sugar can lower the freezing point of the mixture. If you have not added enough sugar, the mixture will freeze into ice blocks instead of slush. It may lead to the freezing of the cylinder, causing the current refrigeration cylinder's refrigeration solenoid valve to close, running the cylinder freezing protection program. If this happens, turn off the machine for 10 minutes, add more sugar or concentrate until a paste-like substance appears.

To make slush for alcoholic beverages, you need to set the temperature between -5°C to -9°C. The alcohol content should not exceed 13%. Otherwise, it may not turn into slush. Note: If the slush is formed but the mixer gets stuck and cannot rotate, please increase the slush forming temperature.

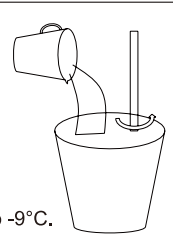

2. Open the lid

Follow the instructions below to remove the lid.

- A. Raise the back of the lid.
- B. Then, push a little in the direction of the arrow to remove the whole lid.

Warning: do not open the lid by force.

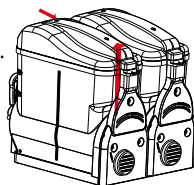

3. Pour in the raw materials

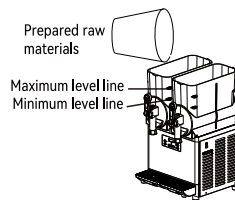

Note: do not load hot liquid (temperature more than 24 degrees Celsius). The raw material should not exceed the maximum level. line (about 10L) or lower than the minimum level (about 6L). Mix the ingredients well and pour them into two cylinders,

4. Close the lid

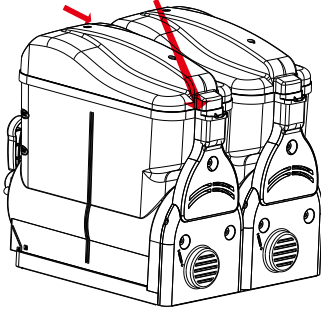

Warning: only when the machine is turned off or not plugged in can the raw material be poured into the bucket.

Close the lid after the raw material is poured.

5. Start the machine

First, plug the machine into the socket, and turn on the power on the operation panel. Then, turn on the light, Stirring 1, Stirring 2 in turn, and finally turn on the compressor and the machine begins to work automatically. After the inner material of the bucket is formed, the cooling of the cylinder block will be stopped. If the sherbet is not hard enough, increase the hardness by adjusting the hardness knob.

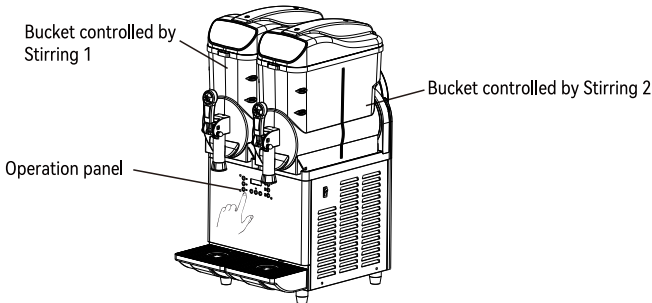

Note: if you only open the unilateral bucket, you only need to turn on the corresponding stirring switch, instead of opening two mixing switches at the same time, which may cause damage to the bucket without raw materials.

It is forbidden to insert fingers into the machine when it is working, which may endanger your health.

6. Produce the sherbet

Put the container under the material outlet, then press the beater handle, and the slushy made in the bucket will flow out automatically.

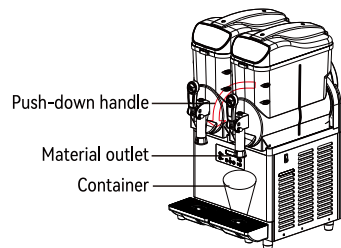

7.Simple cleaning of material cylinder

- A. Release all the materials in the bucket.
- B. Turn off the power.
- C. Prepare hot water no more than 50 °C, then open the lid of the bucket and pour the hot water into the tank.
- D. Turn on the power supply, then press the corresponding stirring switch and let the stirrer stir for 0.5-1 minute.
- E. Let out all the hot water in the bucket, and then repeat the operation for more than 2-4 times.
- F. Turn off the stirring switch and the power supply.

Note: please pour clean hot water into the corresponding bucket that needs to be cleaned, do not exceed the maximum water level marked on the bucket, If you want to thoroughly clean the machine, please shut down the machine. The starting time should not exceed 2 minutes.

Cleaning and Maintenance



Before cleaning or maintaining the external parts, make sure that the machine power switch is off and that the power plug has been unplugged.
Be sure to bring protective equipment (rubber gloves, protective glasses, etc.) before any cleaning or maintenance, which will ensure your safety.

Preparation before cleaning

- Clean utensils (buckets, soft brushes, soft rags).
- Clear water and hot water not exceeding 50 °C.
- Food grade neutral detergent.
- Food-grade disinfectant.
- Food grade lubricant (eg Vaseline).

Operations during cleaning and maintenance.

- Wear protective gloves.
- Do not use strong acids, bases or flammable substances.
- Do not use rough objects or metal sponges to clean machines and other parts.
- Do not spill the cleaning liquid on the surrounding area.

- Do not clean parts in the bucket.
- Do not immerse the machine in water.
- Clean with a disinfectant that meets the requirements of food hygiene.
- Use appropriate food-grade neutral cleaning agents to avoid damage to parts.
- After cleaning, please make sure that all protective covers or safety devices that have been removed or opened have been put back in place and that they are safe and correct.

Cleanliness and hygiene are matters that need to be taken seriously and are important practices based on health standards to ensure the quality of drinks.

Note: The bucket must be cleaned at least once a day, in any case, it must be in line with the health standards implemented in the country, and the frequency of cleaning may need to be increased according to the actual situation. For more information, please consult the product supplier. If the machine is not in continuous use throughout the day, wipe the material outlet area with a clean soft dishcloth (box area below).

Do not clean or maintain the cleaning machine when the plug is not unplugged or the power switch is not turned off. Not thorough cleaning will lead to a large number of bacteria.

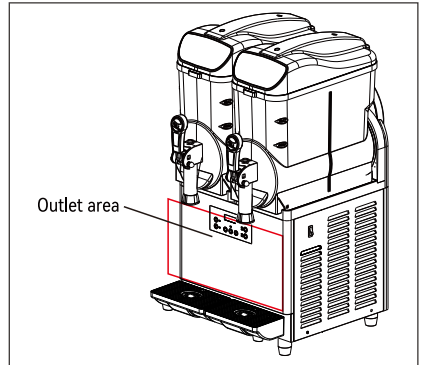

Steps for cleaning

1. Empty the raw materials in the bucket.

Only turn on the stirring function, then place the container under the outlet and press the beater handle to clean the material in the cylinder. After draining the raw materials from the bucket, turn off the power, and then unplug the machine.

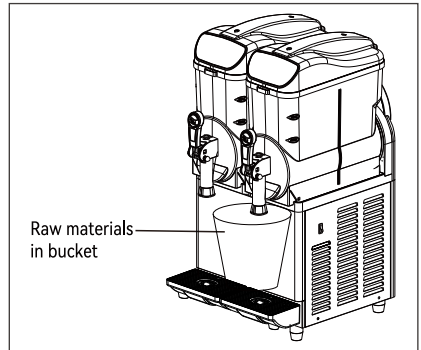

2. Remove the outlet assembly.

Loosen the left handle pin nut on the hand pin counterclockwise, remove the handle pin, then remove the handle, then remove the upper cover of the discharge spring and the discharge spring, and finally remove the valve stem.

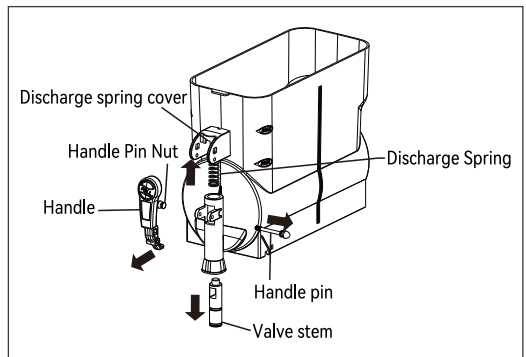

Clean the removed outlet assembly in clean water.

Note: if there is a large amount of raw material or liquid residue in the bucket, do not disassemble the material outlet assembly.

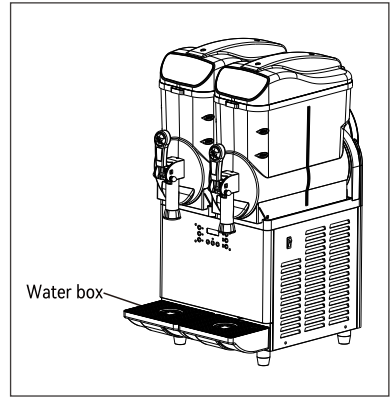
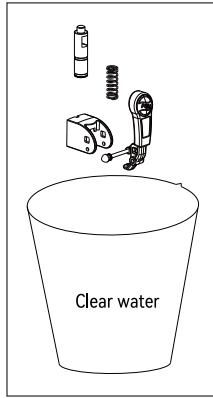

3. Remove the bucket assembly

Disassembling the bucket is the most basic operation to ensure the thorough cleaning. Please follow the following steps to remove the bucket.

A. Remove the bucket cover.

B. Hold the discharge outlet by hand and lift the front end of the bucket up, so that the front end of the bucket is stuck, which is higher than the limit of the bucket seat.

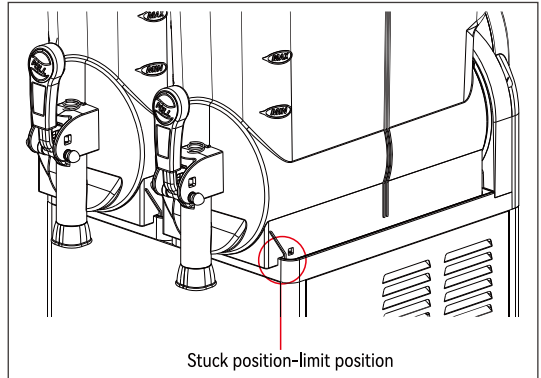

C. Gently push the bucket forward from the back end of the bucket to remove the bucket.

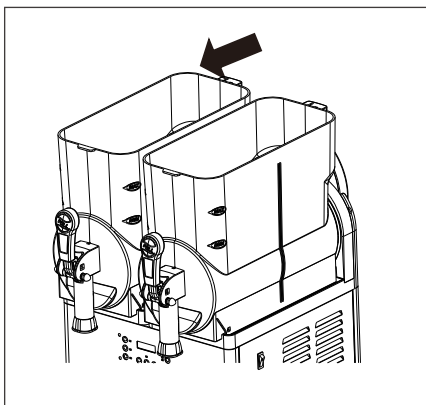

D. Remove the stirrer, the bell mouth sealing ring and the rear sealing ring of the bucket.

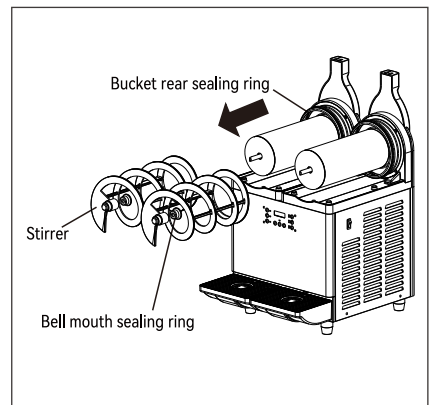

4. Disconnect the water box

First, pull the residual pipe out of the water box, and then lift the water box up vertically to remove the water box.

When disassembling the water box, do not drag the residual pipe at will, so as not to damage the residual pipe. The water box should be emptied and cleaned every day.

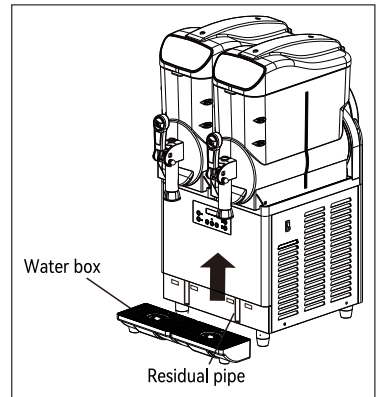

5. Cleaning accessories.

All removed parts should be thoroughly cleaned.



Note: the cleaning method must conform to the current health standards of the country where the machine is used.

Please follow the following methods to clean the parts:

- Pour an appropriate amount of neutral cleaning agent into a container of appropriate size, and then add the appropriate proportion of water to dilute the cleaning agent.
- Clean the surface of the removed parts with a soft rag glued to a diluted cleaning agent, and then rinse the parts thoroughly with clean water.
- Pour the right amount of food-grade disinfectant into another container of the right size, and then add the appropriate proportion of water to dilute it.
- Thoroughly rinse the parts with a cleaning agent and soak them in a diluted disinfectant for about 30 minutes, then take them out and rinse thoroughly with clean water.
- Place the disinfected and cleaned parts in a clean place to dry naturally.

6. Clean the evaporator

Wipe the evaporator surface and evaporator base with a soft rag glued with diluted cleaning agent, then wipe the evaporator surface and evaporator base 2-3 times with a clean wet dishcloth. Wipe the evaporator surface and evaporator base several times with a soft rag glued to dilute disinfectant, leaving the disinfectant on the wiping surface. After half an hour, wipe the evaporator surface and evaporator base thoroughly with a clean wet dishcloth.

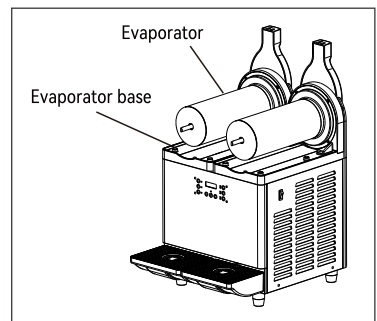

7. Clean the bucket cover

Wipe the outer surface of the bucket cover with a clean wet rag. Wipe the bottom surface of the bucket lid several times with a soft dishcloth glued to dilute disinfectant, leaving the disinfectant on the wiping surface. After half an hour, wipe the bottom surface of the bucket cover thoroughly with a clean wet rag, and then dry the bottom surface with a clean dry rag.

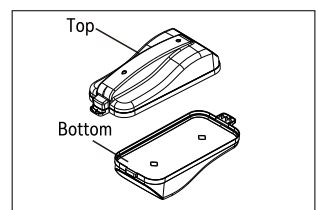

8. Clean the fuselage

1. Wipe the fuselage with a clean soft cloth dampened with the diluted cleaning agent.
2. Wipe the fuselage with a soft wet rag stained with clean water.
3. Dry the fuselage with a clean dry rag.

Assembly of Parts

All parts that have been cleaned and sterilized must be reinstalled correctly. Some parts must be guaranteed to moisturize so that they can be used for a longer time.

• Assembly of bell mouth sealing ring

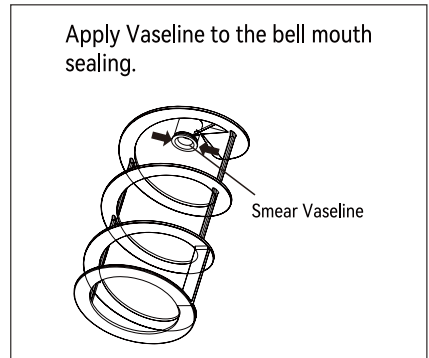
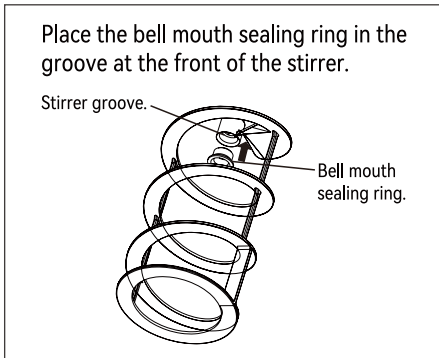

• Assembly of stirrer

Put the rear sealing ring of the evaporator into the base of the evaporator, and then smear Vaseline on the outer surface of the sealing ring behind the evaporator. Install the assembled stirrer into the evaporator, and the end of the stirrer limit is inserted into the drive shaft. Then, push the stirrer forward gently and rotate the stirrer until the stirrer limit head just snaps into the limit of the drive shaft, and the bell mouth sealing ring can come into contact with the evaporator.

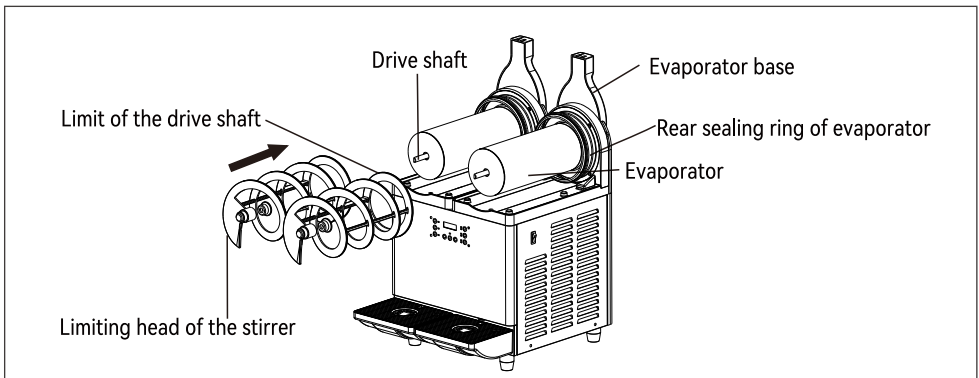

• Assembly of buckets

Lift the front end of the evaporator slightly, and then put the bucket into the evaporator. Put the rear end of the bucket into the rear sealing ring of the evaporator, and then continue to push the bucket forward until the front end of the material barrel is locked into the limit of the bucket seat.

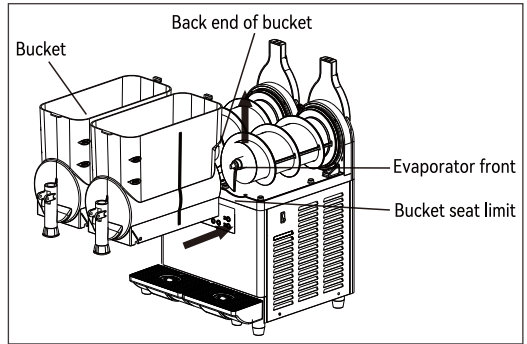

• Assembly of material outlet assembly

- A. Put the valve stem under the outlet of the bucket.
- B. Put the discharge spring down from the top of the bucket outlet and place it on the valve stem.
- C. Insert the front end of the handle into the stem limit slot.
- D. Press the card groove on the back of the discharge spring along the material outlet limit.
- E. Adjust the handle rotation hole, the discharge spring upper cover fixing hole and the material outlet cross pin hole to a line, then pass the cross pin through, and then tighten the cross-pin nut on the cross pin.

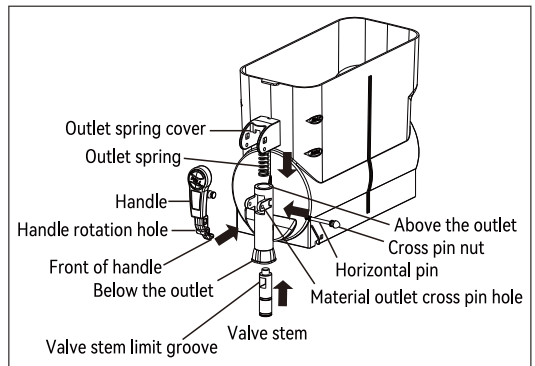

Note: the valve stem sealing ring should be smeared with Vaseline before the outlet can be installed.

• Assembly of the tank cover

Insert the slot at the front end of the bucket cover into the upper position at the front end of the bucket, and then insert the plug at the back end of the bucket cover into the bucket socket.

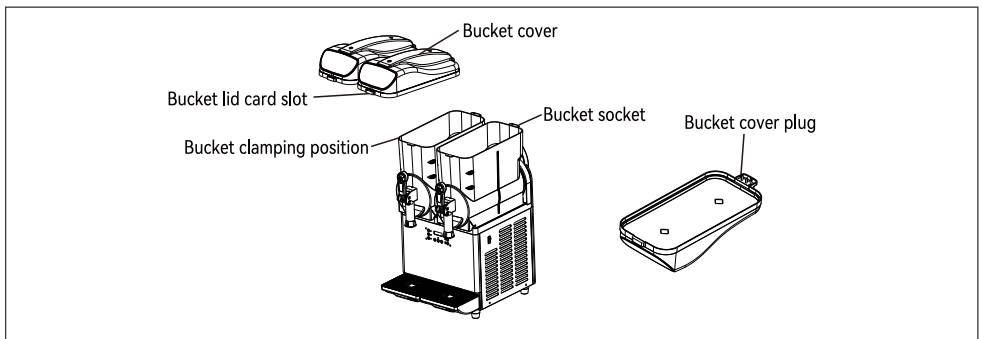

Condenser Cleaning

Working for a period of time, the condenser will stick to dust to affect the heat dissipation, and the cooling effect will become worse (such as: the output of the Slush Machine decreases or it is difficult to take shape at the same time). Please clean once a month (if the environment is poor, please clean once a month), be sure to ask a professional cleaner to clean, turn off the power before cleaning, and be careful not to damage the fins of the condenser.

Condenser location of double-headed Slush Machine. Remove the cover on the left board. Remove the four retaining screws with a Phillips screwdriver. Just remove the left plate. Condenser location of single-head Slush Machine. Remove the upper cover of the left and right-side plate. Remove the left and right-side plate retaining screws with a Phillips screwdriver. Remove the left and right-side plate, remove the rear panel fixing screw with a Phillips screwdriver, and remove the rear panel.

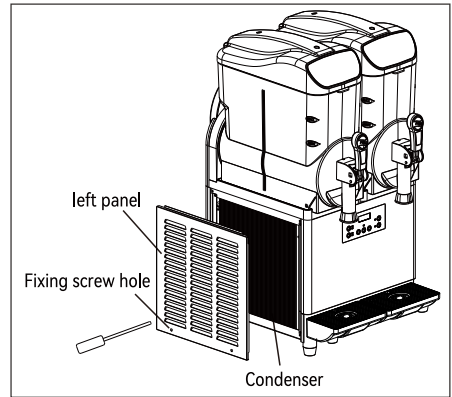

Circuit Schematic

Wiring diagram of single head slush machine

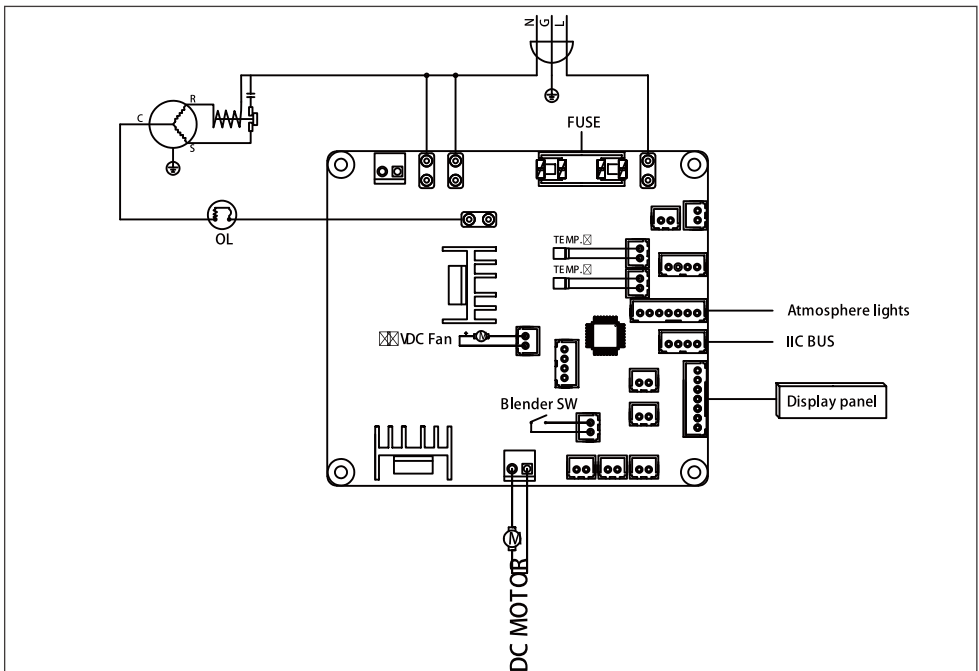

Wiring diagram of double-headed Slush Machine

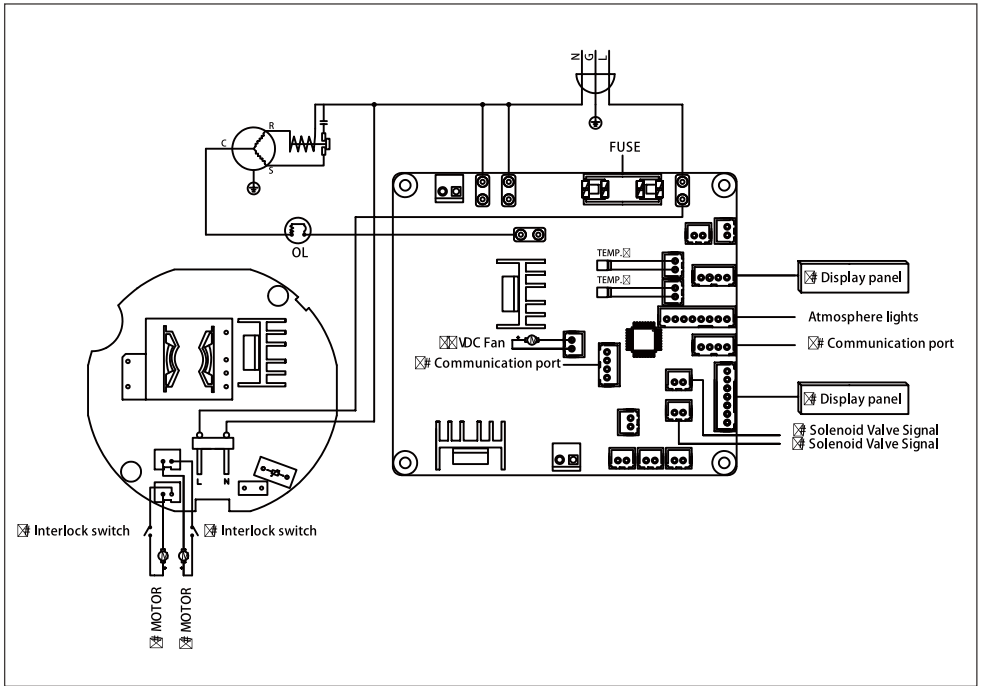

Wiring diagram of three-head Slush Machine

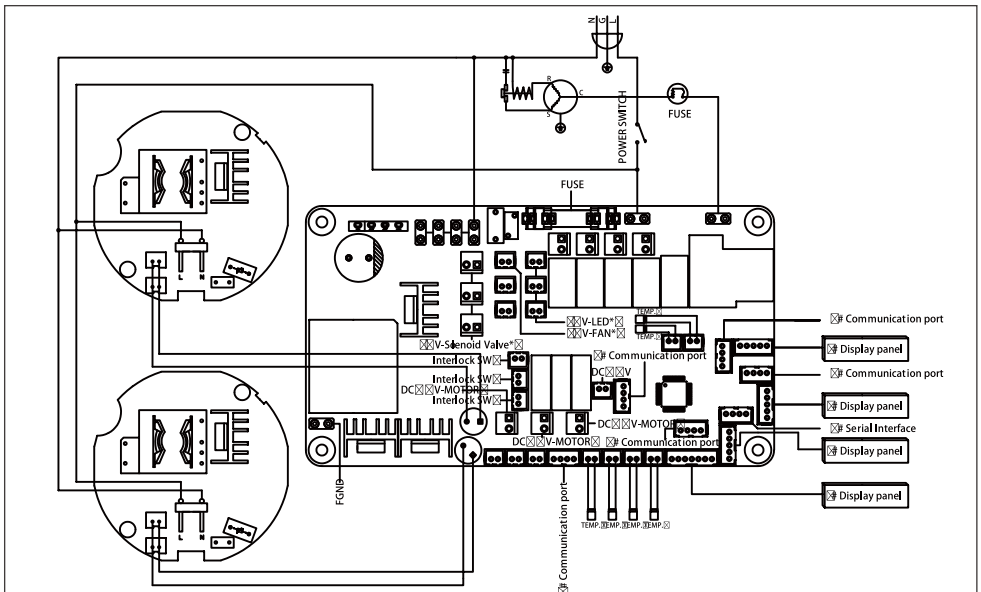

Environmental Protection List

1. The name and content of non-environmentally friendly substances or elements in the product.

Part Name	Non-environmentally friendly substances or elements					
	Pb	Hg	Cd	Cr(vl)	PBB	PBDE
Compressor	✘	○	○	✘	○	○
Fan	✘	○	○	○	○	○
Motor	✘	○	○	○	○	○

○: Indicating that the content of the harmful substance in all homogeneous materials of the component is below the limit specified in GB/T 26572.

✘: Indicating that the content of the hazardous substance in at least one of the homogeneous materials of the component exceeds the limit specified in GB/T 26572.

Note: The parts of this product are made of non-toxic and harmless green materials. The non-environmentally friendly substances or elements contained in them are unable to be completely replaced due to the limitations of the global technology and process level. However, the content of non-environmental protection substances or elements in this product is very small, long-term use will not cause harm to the human body, please rest assured to use.

2. Description of environmental protection logo:

This product adopts the industry standard SJ/T 11364 Labeling Requirements for the Restricted Use of Hazardous Substances in Electrical and Electronic Products in accordance with the relevant provisions of the national regulations Administrative Measures for the Restriction of the Use of Hazardous Substances in Electrical and Electronic Products.



3. Instructions on recycling and disposal of waste electronic and electrical products:

In order to better care for and protect the earth, when the user no longer needs this product or the product life ends, please abide by the laws and regulations related to the recycling of waste electronic and electrical products in the country where the machine is used and hand it over to the local manufacturer with nationally recognized qualification for recycling. Any product with a cross-label of trash bins is a reminder that people are obligated to sort and recycle waste. The research on the correct disposal of abandoned products will promote environmental protection.



Troubleshooting Instructions

Faults	Cause Analysis	Solutions
The machine cannot be turned on	No power input	Insert the power plug into a suitable outlet
	Machine power switch is not turned on	Turn the power switch on
The material outlet is leaking	Parts located at material outlet are not lubricated	Lubricate the outlet parts
	Damaged valve stem seal	Replace the stem seal
Raw material is leaking from the back of the bucket	Bucket not installed in place	Check the tank installation position
	Bucket seals are not lubricated	Apply lubricant
	The power switch on the right side is not turned on	Replace the sealing ring
The stirrer can't turn	Bucket not installed in place	Switch on
	Evaporator's surface is frozen	Turn off the power switch and let the ice melt

The machine does not make sherbet	The master switch is not turned on	Turn on the master switch
	The sherbet of the serrano is not adjusted to the right level	Adjust the hardness of sherbet
	The condenser is too dirty	Clean the condenser
	The Slush Machine is close to the heat source, and the heat dissipation around it is poor.	Put the machine in the right place
	Evaporator freezing cylinder	The machine starts the freezing cylinder protection, wait for five minutes The machine restores cooling by itself
The stirrer is noisy	The bell mouth sealing ring is not installed properly	Check whether the sealing ring is installed in place
	The Slush Machine is very hard	Re-adjust the hardness
	Bell mouth sealing not lubricated or damaged	Apply lubricant or replace with new one
	The raw sugar content is too low	Re-adjust the ratio of ingredients, can not replace sugar with sweetener.
The material outlet can not produce any the material	Too much ice in the bucket	Shut down and let the ice cubes melt
The sherbet has black stains	The bucket is not clean	Re-clean
	Dirty stirrer seal	Re-clean
	Damaged stirrer seal	Replace with new seal
1RH/2RH/3RHalarm	The corresponding bowl temperature sensor is broken	Replace the temperature sensor
If the machine failure is not caused by the above reasons or the above suggestions can not solve the problem, please contact the seller.		



This device complies with Part 15 of the FCC Rules.

Operation is subject to the following two conditions: 1. This device may not cause harmful interference; 2. This device must accept any interference received, including interference that may cause undesired operation.



GGM Gastro International GmbH
Weinerpark 16
D-48607 Ochtrup

www.ggmgastro.com

info@ggmgastro.com

+49 2553 7220 0